

---

---

**Mineral and sapphire watch-glasses —  
Part 2:  
Assembly to the case by adhesive or  
using a gasket**

*Verres de montres minéraux et en saphir —  
Partie 2: Fixation à la boîte par collage ou à l'aide d'un joint*

**iTeh STANDARD PREVIEW  
(standards.iteh.ai)**

[ISO 14368-2:2003](https://standards.iteh.ai/catalog/standards/sist/81972c1b-1c17-4054-87e1-71bd8bcf6f3e/iso-14368-2-2003)

<https://standards.iteh.ai/catalog/standards/sist/81972c1b-1c17-4054-87e1-71bd8bcf6f3e/iso-14368-2-2003>



**PDF disclaimer**

This PDF file may contain embedded typefaces. In accordance with Adobe's licensing policy, this file may be printed or viewed but shall not be edited unless the typefaces which are embedded are licensed to and installed on the computer performing the editing. In downloading this file, parties accept therein the responsibility of not infringing Adobe's licensing policy. The ISO Central Secretariat accepts no liability in this area.

Adobe is a trademark of Adobe Systems Incorporated.

Details of the software products used to create this PDF file can be found in the General Info relative to the file; the PDF-creation parameters were optimized for printing. Every care has been taken to ensure that the file is suitable for use by ISO member bodies. In the unlikely event that a problem relating to it is found, please inform the Central Secretariat at the address given below.

**iTeh STANDARD PREVIEW**  
**(standards.iteh.ai)**

ISO 14368-2:2003

<https://standards.iteh.ai/catalog/standards/sist/81972c1b-1c17-4054-87e1-71bd8bcf6f3e/iso-14368-2-2003>

© ISO 2003

All rights reserved. Unless otherwise specified, no part of this publication may be reproduced or utilized in any form or by any means, electronic or mechanical, including photocopying and microfilm, without permission in writing from either ISO at the address below or ISO's member body in the country of the requester.

ISO copyright office  
Case postale 56 • CH-1211 Geneva 20  
Tel. + 41 22 749 01 11  
Fax + 41 22 749 09 47  
E-mail [copyright@iso.org](mailto:copyright@iso.org)  
Web [www.iso.org](http://www.iso.org)

Published in Switzerland

## Foreword

ISO (the International Organization for Standardization) is a worldwide federation of national standards bodies (ISO member bodies). The work of preparing International Standards is normally carried out through ISO technical committees. Each member body interested in a subject for which a technical committee has been established has the right to be represented on that committee. International organizations, governmental and non-governmental, in liaison with ISO, also take part in the work. ISO collaborates closely with the International Electrotechnical Commission (IEC) on all matters of electrotechnical standardization.

International Standards are drafted in accordance with the rules given in the ISO/IEC Directives, Part 2.

The main task of technical committees is to prepare International Standards. Draft International Standards adopted by the technical committees are circulated to the member bodies for voting. Publication as an International Standard requires approval by at least 75 % of the member bodies casting a vote.

Attention is drawn to the possibility that some of the elements of this document may be the subject of patent rights. ISO shall not be held responsible for identifying any or all such patent rights.

ISO 14368-2 was prepared by Technical Committee ISO/TC 114, *Horology*, Subcommittee SC 13, *Watch-glasses*.

ISO 14368 consists of the following parts, under the general title *Mineral and sapphire watch-glasses*:

— *Part 1: Dimensions and tolerances*

— *Part 2: Assembly to the case by adhesive or using a gasket*

— *Part 3: Qualitative criteria and test methods*

iTeh STANDARD PREVIEW  
(standards.iteh.ai)

ISO 14368-2:2003  
<https://standards.iteh.ai/catalog/standards/sist/61972c1b-1c17-4054-87e1-71bd8bcf6f3e/iso-14368-2-2003>

**iTeh STANDARD PREVIEW**  
**(standards.iteh.ai)**

ISO 14368-2:2003

<https://standards.iteh.ai/catalog/standards/sist/81972c1b-1c17-4054-87e1-71bd8bcf6f3e/iso-14368-2-2003>

# Mineral and sapphire watch-glasses —

## Part 2: Assembly to the case by adhesive or using a gasket

### 1 Scope

This part of ISO 14368 specifies dimensional requirements of the interface for the assembly to the case by adhesive or using a gasket for round-shaped mineral and sapphire watch-glasses.

### 2 Normative references

The following referenced documents are indispensable for the application of this document. For dated references, only the edition cited applies. For undated references, the latest edition of the referenced document (including any amendments) applies.

ISO 286-1, *ISO system of limits and fits — Part 1: Bases of tolerances, deviations and fits*

ISO 286-2, *ISO system of limits and fits — Part 2: Tables of standard tolerance grades and limit deviations for holes and shafts*

ISO 14368-1, *Mineral and sapphire watch-glasses — Part 1: Dimensions and tolerances*

### 3 Terms, definitions and symbols

#### 3.1 Terms and definitions

For the purposes of this document, the terms and definitions given in ISO 286-1 and ISO 286-2 apply.

#### 3.2 Symbols

The symbols and terms used in Figures 1, 2 and 3 are given in Table 1.

Table 1 — Symbols and terms

Symbol	Term
$c$	gasket compression in % of width
$d$	diameter of the glass
$d_1$	dial opening diameter
$d_2$	diameter of the circular groove of the glass
$d_3$	external gasket diameter (non-compressed)
$d_4$	internal gasket diameter (non-compressed)
$e_1$	gasket thickness
$e_2$	thickness of compressed gasket
$e_3$	space for adhesive
$h_1$	cylindrical side height of the glass
$h_2$	height of the lower slope of the glass
$h_3$	height of the upper slope of the glass
$h_4$	determining height for glasses assembled with adhesive
$h_5$	height of the circular groove of the glass
$h_6$	height of the internal slopes of the gasket
$h_7$	height of compressed gasket
$h_8$	height of non-compressed gasket
$t$	total thickness of the glass
$\beta$	angle of the lower slope of the glass
$\gamma$	angles of the internal slopes of the gasket

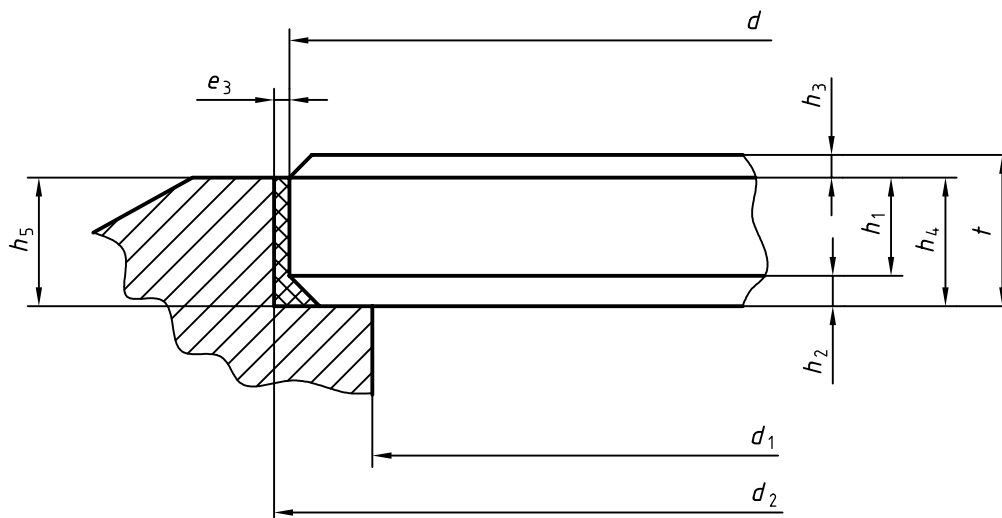

Figure 1 — Glass secured by adhesive

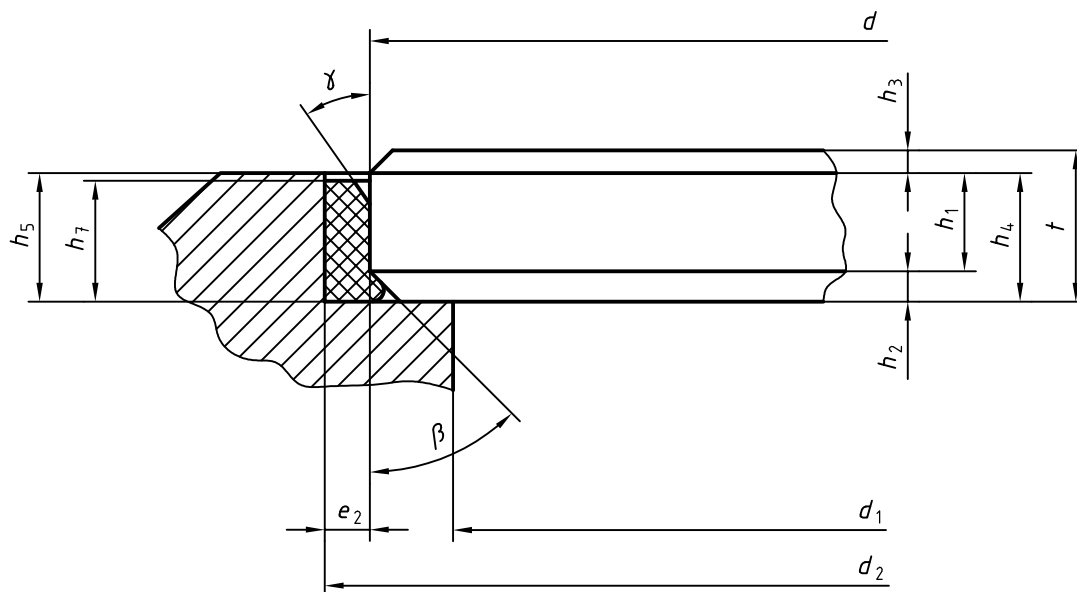

Figure 2 — Fixing the glass with a gasket



Figure 3 — Details of the gasket

## 4 Dimensions

### 4.1 Glass secured by adhesive

#### 4.1.1 General

The dimensions for glass secured by adhesive shall be as given in Figure 1.

#### 4.1.2 Opening

The dial opening diameter is calculated using the following equation:

$$d_1 \leq d - 0,40 \text{ mm or } d - (2 h_2 + 0,20 \text{ mm})$$

where  $h_2$  is in accordance with ISO 14368-1.

#### 4.1.3 Glass circular groove

The diameter of the circular groove is calculated using the following equation:

$$d_2 = d + 2 e_3$$

where  $e_3 = 0,03$  mm to 0,05 mm

### 4.2 Glass secured with a gasket

#### 4.2.1 General

The dimensions for glass secured with a gasket shall be as given in Figures 2 and 3.

#### 4.2.2 Opening

The dial opening diameter is calculated using the following equation:

$$d_1 \leq d - [(2 h_2 \times \tan\beta) + 0,20 \text{ mm}]$$

where  $h_2$  is in accordance with ISO 14368-1.

#### 4.2.3 Glass circular groove

The diameter of the glass circular groove is calculated using the following equation:

$$d_2 = d + 2 e_2$$

ISO 14368-2:2003  
<https://standards.iteh.ai/catalog/standards/sist/81972c1b-1c17-4054-87e1-71bd8bcf6f3e/iso-14368-2-2003>

#### 4.2.4 Assembly

The assembly shall be carried out using either of the two following methods.

- a) The gasket is first housed in the groove and then the glass is driven in.
- b) The gasket is first fitted onto the glass surround and is then driven into the glass groove; this method is valid only for L gaskets, which are not dealt with in this part of ISO 14368.

## 5 Gasket dimensions

The gasket dimensions shall be as given in Table 2.



Table 2 — Gasket dimensions

Term	Dimension
External gasket diameter	$d_3 = d_2$
Internal gasket diameter	$d_4 = d_3 - 2 e_1$ ( $e_1 = e_2 + c$ )
Gasket height after fitting	$h_7$ max. = $h_5 - 0,05$ mm
Height of the circular groove of the glass	$h_5 = h_4$ or $h_5 = t - h_3$
Compression	$c = 15\%$ to $35\%$ of $e_1$ (by taking into account the characteristics of the gasket material)
Internal slope angles of the gasket	$\gamma = 30^\circ$ to $45^\circ$
Height of the internal slopes of the gasket	$h_6 = 0,10$ mm to $0,30$ mm
Height of gasket before fitting	$h_8 =$ define according to the material

## 6 Tolerances

The tolerances shall be as given in Table 3.

### Table 3 — Tolerances

Symbol	Tolerance
$d$	in accordance with ISO 14368-1
$t$	in accordance with ISO 14368-1
$d_1$	J <sub>s</sub> 9
$d_2$	J <sub>s</sub> 8
$d_3$	s10
$h_5$	j <sub>s</sub> 9