**Footwear — Test methods for uppers —
Resistance to damage on lasting**

Chaussures — Méthodes d'essai des tiges — Aptitude au montage

iTeh STANDARD PREVIEW
(standards.iteh.ai)

[ISO 17693:2004](https://standards.iteh.ai/catalog/standards/sist/b76bf881-2759-4b18-b466-92bd15ab4a09/iso-17693-2004)

<https://standards.iteh.ai/catalog/standards/sist/b76bf881-2759-4b18-b466-92bd15ab4a09/iso-17693-2004>



Reference number
ISO 17693:2004(E)

PDF disclaimer

This PDF file may contain embedded typefaces. In accordance with Adobe's licensing policy, this file may be printed or viewed but shall not be edited unless the typefaces which are embedded are licensed to and installed on the computer performing the editing. In downloading this file, parties accept therein the responsibility of not infringing Adobe's licensing policy. The ISO Central Secretariat accepts no liability in this area.

Adobe is a trademark of Adobe Systems Incorporated.

Details of the software products used to create this PDF file can be found in the General Info relative to the file; the PDF-creation parameters were optimized for printing. Every care has been taken to ensure that the file is suitable for use by ISO member bodies. In the unlikely event that a problem relating to it is found, please inform the Central Secretariat at the address given below.

iTeh STANDARD PREVIEW
(standards.iteh.ai)

ISO 17693:2004

<https://standards.iteh.ai/catalog/standards/sist/b76bf881-2759-4b18-b466-92bd15ab4a09/iso-17693-2004>

© ISO 2004

All rights reserved. Unless otherwise specified, no part of this publication may be reproduced or utilized in any form or by any means, electronic or mechanical, including photocopying and microfilm, without permission in writing from either ISO at the address below or ISO's member body in the country of the requester.

ISO copyright office
Case postale 56 • CH-1211 Geneva 20
Tel. + 41 22 749 01 11
Fax + 41 22 749 09 47
E-mail copyright@iso.org
Web www.iso.org

Published in Switzerland

Foreword

ISO (the International Organization for Standardization) is a worldwide federation of national standards bodies (ISO member bodies). The work of preparing International Standards is normally carried out through ISO technical committees. Each member body interested in a subject for which a technical committee has been established has the right to be represented on that committee. International organizations, governmental and non-governmental, in liaison with ISO, also take part in the work. ISO collaborates closely with the International Electrotechnical Commission (IEC) on all matters of electrotechnical standardization.

International Standards are drafted in accordance with the rules given in the ISO/IEC Directives, Part 2.

The main task of technical committees is to prepare International Standards. Draft International Standards adopted by the technical committees are circulated to the member bodies for voting. Publication as an International Standard requires approval by at least 75 % of the member bodies casting a vote.

Attention is drawn to the possibility that some of the elements of this document may be the subject of patent rights. ISO shall not be held responsible for identifying any or all such patent rights.

ISO 17693 was prepared by the European Committee for Standardization as EN 13511:2001. This International Standard includes corrigendum EN 13511:2001/AC:2003 and was adopted under a special "fast-track procedure" by technical committee ISO/TC 216, Footwear in parallel with its approval by the ISO member bodies.

Throughout the text of this document, read "...this European Standard..." to mean "...this International Standard...".

[ISO 17693:2004](https://standards.iteh.ai/catalog/standards/sist/b76bf881-2759-4b18-b466-92bd15ab4a09/iso-17693-2004)

<https://standards.iteh.ai/catalog/standards/sist/b76bf881-2759-4b18-b466-92bd15ab4a09/iso-17693-2004>

iTeh STANDARD PREVIEW
(standards.iteh.ai)

ISO 17693:2004

<https://standards.iteh.ai/catalog/standards/sist/b76bf881-2759-4b18-b466-92bd15ab4a09/iso-17693-2004>

1 Scope

This European Standard specifies a test method to determine the lastability of uppers or complete upper assembly irrespective of the material in order to assess the suitability for the end use.

2 Normative references

This European Standard incorporates by dated or undated reference, provisions from other publications. These normative references are cited at the appropriate places in the text, and the publications are listed hereafter. For dated references, subsequent amendments to or revisions of any of these publications apply to this European Standard only when incorporated in it by amendment or revision. For undated references the latest edition of the publication referred to applies (including amendments).

EN 12222, *Footwear - Standard atmospheres for conditioning and testing of footwear and components for footwear.*

prEN ISO 2418, *Leather - Chemical, physical, mechanical and fastness tests – Sampling.*

3 Terms and definitions

For the purposes of this European Standard, the following terms and definitions apply.

3.1

resistance to damage on lasting

ability of a material to be stretched simultaneously in all directions (distended) without being damaged

3.2

upper

materials forming the outer face of the footwear which is attached to the sole assembly and covers the upper dorsal surface of the foot. In the case of boots this also includes the outer face of the material covering the leg. Only the materials that are visible are included, no account should be taken of underlying materials

3.3

complete upper assembly

finished upper, fully seamed, joined or laminated together as appropriate, comprising the centre material and any lining(s) together with all components such as interlinings, adhesives, membranes, foams or reinforcements, but excluding toe puffs and stiffeners

NOTE The complete upper assembly can be flat, 2- dimensional or comprise lasted upper in the final footwear.

4 Apparatus and material

The following apparatus and material shall be used:

4.1 Test machine (see Figures 1 and 2), including the following:

4.1.1 Means of clamping the test specimen round its edge leaving a central circular free area of diameter 25,00 mm \pm 0,5 mm. The design of the clamping system of the machine shall ensure that the test specimen does not slip during the test, and shall neither stretch nor compress the central area of the test specimen as it is clamped.

Dimensions in millimetres
All dimensions $\pm 0,025$ mm

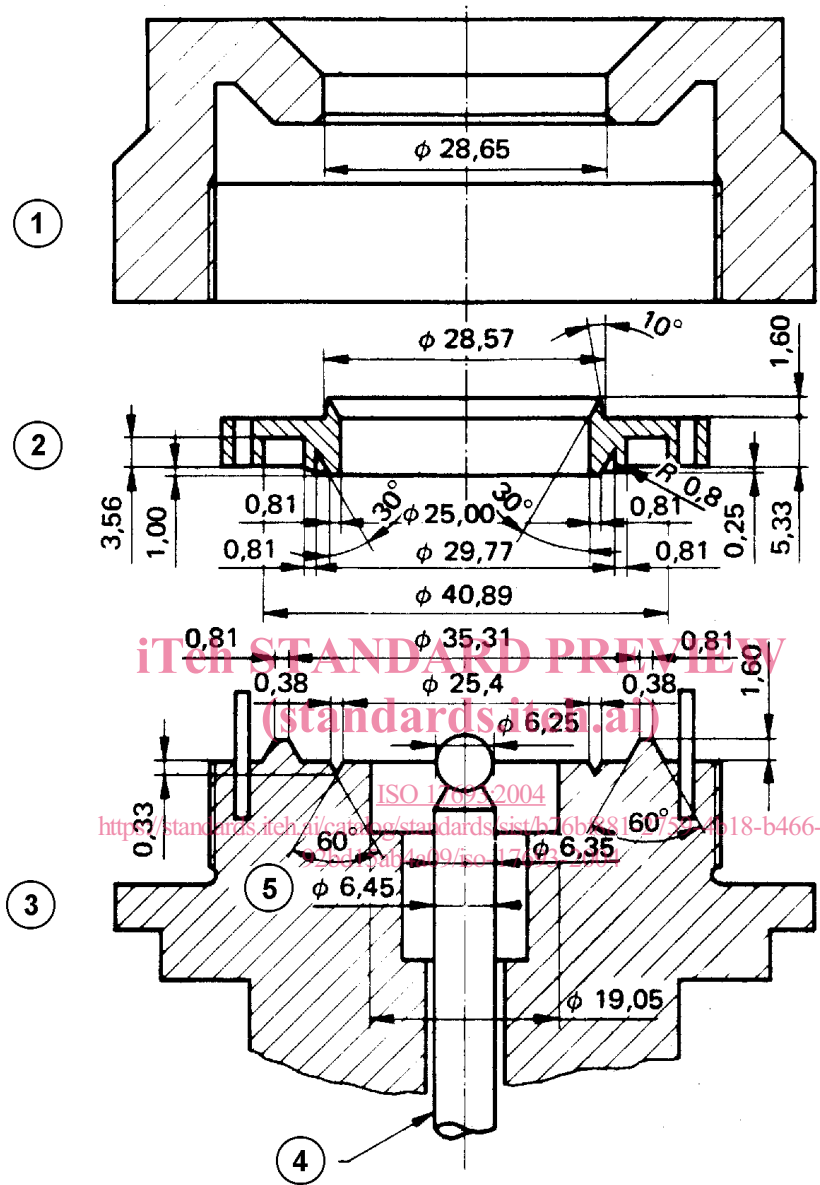

Key

- | | |
|--------------|----------------|
| 1 Cap | 4 Rod and ball |
| 2 Clamp ring | 5 Bore |
| 3 Head | |

Figure 1 — Details of clamp and head

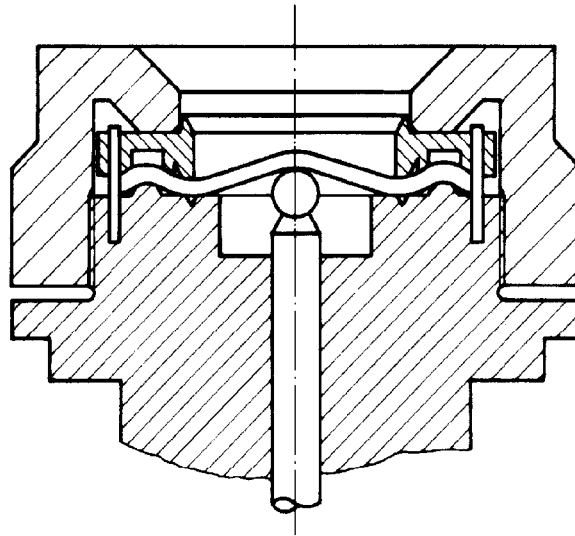

Figure 2 — Cross Section of clamping head with test piece in position

- 4.1.2 Moveable plunger with a $6,25 \text{ mm} \pm 0,05 \text{ mm}$ diameter spherical ball on the end.
- 4.1.3 Means of moving the plunger relative to the test specimen clamp at a speed of $0,20 \text{ mm/s} \pm 0,05 \text{ mm/s}$.
- 4.1.4 Means of monitoring the distension (travel of the plunger from zero) to an accuracy of $\pm 0,05 \text{ mm}$.
- 4.1.5 Means of monitoring the force on the plunger within the range 0 N to 800 N to an accuracy of $\pm 10 \text{ N}$.
- 4.2 **Press knife** or similar means for cutting test specimens.

5 Sampling and conditioning

5.1 Test specimens shall be of a sufficient size to allow them to be clamped firmly on the test machine (see 4.1), so that they do not slip during the test.

In the case of leather use prEN ISO 2418 to select the sampling position from the butt region of the skin or side.

For non-leather materials cut 3 test specimens from a range of positions across the full usable width and length of the sheet material. For a material with a woven structure this shall prevent any two test specimens containing the same warp or weft threads.

5.2 For test specimens from footwear uppers, they shall not be cut from any areas containing seams or perforations and any other design features which mean that the test specimen will not be of uniform thickness across its entire surface area. Furthermore, no test specimens shall be cut from areas of finished shoe uppers which are subjected to strains during lasting, especially the toe and backpart areas. Test specimens shall be prepared from complete upper assemblies when the lining material is permanently attached to the upper material.

It can be that it is impossible to cut a test specimen of sufficient size from certain types of footwear especially children's and the test specimen size shall not be reduced. If it is not possible to cut the correct size test specimen from a shoe upper the materials themselves shall be tested.

5.3 Place the test specimens in a conditioned environment as specified in EN 12222 for 24 h prior to test and carry out the test in this atmosphere.

6 Test method

6.1 Principle

A circular test specimen is clamped round its edge and is gradually distended by forcing a small metal ball attached to a plunger through the test specimen. At a certain distension, measured in terms of distance travelled by the plunger, either cracks appear in the surface of the material or a layer of the material sustains permanent physical damage; this distension is recorded as the first damage point.

At a higher distension the material usually bursts and this distension can also be recorded. Throughout the test the travel of, and force on the plunger is monitored so that if required a plot of force against distension can be produced.

6.2 Procedure

6.2.1 Ensure the test machine is set with the central plunger retracted to zero or minimum distension. If it has a maximum force pointer turn it to zero.

6.2.2 Tightly clamp the test specimen into the test machine so that the ball ended plunger acts on the reverse side of the test specimen (i.e. when testing grain leathers, the ball ended plunger will press against the flesh side of the leather) and the test specimen is flat.

6.2.3 For some thick test specimens a very high clamping force may be necessary whereas with thin test specimens care is required to avoid cutting into the test specimen.

6.2.4 Force the plunger into the test specimen at a rate of $0,20 \text{ mm/s} \pm 0,05 \text{ mm/s}$.

6.2.5 Record the point of first damage as the plunger stretches the test specimen as follows:

- a) When testing leathers the first damage usually occurs in the finish or the surface of the grain. Hence during the test continually observe the surface of the test specimen, at the centre where the maximum distension is taking place. At the first sign of surface cracking, record the force on the plunger and the distension of the test specimen. However, if the grain is still intact, continue until grain crack occurs and record also the distension and force at this point.

Patent leather is a special case because often the grain of the leather cracks before the patent surface film. Particular care is therefore required when observing patent leather test specimens. Two indications of the grain cracking are a small shallow depression in the surface of the film above the crack and a momentary drop in the force on the plunger. If the patent film cracks this shall also be regarded as a "grain crack" whether or not a crack in the grain is visible.

- b) When testing non-leather materials such as coated fabrics the first damage usually occurs within the material, with no visible damage at the surface. Hence during the test continually observe the force on the plunger as the test specimen is stretched. When damage occurs to a layer of the test specimen the force on the plunger either stops rising, or falls, however this may only be momentary. Record this value and the distension of the test specimen at this point.

6.2.6 If the bursting point is required then continue to observe the test specimen and record the distension and force when the spherical end first appears through the sample.

6.2.7 Retract the plunger and remove the test specimen.

EN 13511:2001 (E)

6.2.8 Inspect the marks on the top of the test specimen left by the clamps. If there are signs of slippage occurring during the test, for example evident by a blurring of clamping rings, or of tearing of the clamped edges; reject the results and repeat the procedure with a new test specimen.

6.2.9 Repeat the procedure for the remaining test specimens.

7 Expression of results

Calculate the arithmetic mean of the results for the three test specimens, for distension and force at the:

- a) first damage point, as in 6.2.5;
- b) graincrack (for leathers) if this does not occur at the first damage point;
- c) bursting point, as in 6.2.6, if required;

quoting distension to the nearest 0,1 mm, and force to the nearest 10 N.

8 Test report

The test report shall include the following information:

- a) results expressed in accordance with clause 7;
- b) if testing finished footwear or uppers, a description of the style of shoe tested including commercial style codes;
- c) a description of the material, including a commercial reference, if known;
- d) a description of the test piece (upper or complete upper assembly);
- e) reference to the method of test;
- f) date of testing;
- g) any deviations from this test method.

iteh STANDARD PREVIEW
(standards.iteh.ai)

ISO 17693:2004

<https://standards.iteh.ai/catalog/standards/sist/59-4b18-b466-92bd15ab4a09/iso-17693-2004>