



Designation: D 2061 – 03

Standard Test Methods for Strength Tests for Zippers¹

This standard is issued under the fixed designation D 2061; the number immediately following the designation indicates the year of original adoption or, in the case of revision, the year of last revision. A number in parentheses indicates the year of last reappraisal. A superscript epsilon (ϵ) indicates an editorial change since the last revision or reappraisal.

1. Scope

1.1 These test methods cover the determination of the strengths for zipper and zipper parts. All methods are not suitable for use with all kinds of zipper. The restrictions, if any, are indicated in the scope for each individual test method. The test methods appear as follows:

	Sections
Holding Strengths of Separable Units	25-32
Holding Strength of Slider Lock	82-90
Holding Strength of Stops	17-24
Resistance to Angular Pull-Off of Slider Pull	72-81
Resistance to Cushioned Compression of Sliders	33-42
Resistance to Pull-Off of Slider Pull	62-71
Resistance to Twist of Pull and Slider	52-61
Slider Deflection and Recovery	43-51
Strength of Chains and Elements	9-16

1.2 The values stated in SI units are to be regarded as the standard.

1.3 *This standard does not purport to address all of the safety concerns, if any, associated with its use. It is the responsibility of the user of this standard to establish appropriate safety and health practices and determine the applicability of regulatory limitations prior to use.*

2. Referenced Documents

2.1 ASTM Standards:²

- D 76 Specification for Tensile Testing Machines for Textiles
- D 123 Terminology Relating to Textiles
- D 1776 Practice for Conditioning Textiles for Testing
- D 2050 Terminology Relating to Zippers
- D 2051 Test Method for Durability of Finish of Zippers to Laundering
- D 2052 Test Method for Colorfastness of Zippers to Drycleaning
- D 2053 Test Method for Colorfastness of Zippers to Light

¹ These test methods are under the jurisdiction of ASTM Committee D13 on Textiles and are the direct responsibility of Subcommittee D13.54 on Subassemblies and were developed in cooperation with the American Fastener and Closure Assn.

Current edition approved Dec. 1, 2003. Published December 2003. Originally approved in 1961. Last previous edition approved in 1998 as D 2061 – 93 (1998).

² For referenced ASTM standards, visit the ASTM web site, www.astm.org, or contact ASTM Customer Service at service@astm.org. For Annual Book of ASTM Standards volume information, refer to the standard's Document Summary page on the ASTM web site.

- D 2054 Test Method for Colorfastness of Zipper Tapes to Crocking
 - D 2057 Test Method for Colorfastness of Zippers to Laundering
 - D 2058 Test Method for Durability of Finish of Zippers to Drycleaning
 - D 2059 Test Method for Resistance of Zippers to Salt Spray (Fog)
 - D 2060 Test Methods for Measuring Zipper Dimensions
 - D 2062 Test Methods for Operability of Zippers
- 2.2 *U. S. Government Standard:*
MIL-105D Sampling Procedures and Tables for Inspection by Attributes³

3. Terminology

3.1 Definitions:

3.1.1 For definitions of zipper terms used in this standard, refer to Terminology D 2050. For definitions of other textile terminology used in this standard, refer to Terminology D 123.

4. Significance and Use

4.1 The usefulness of a zipper in service can be evaluated by these tests. No one test determines the suitability of a zipper for a specific end use. Since the tests are inter-related more than one may be needed for a complete evaluation.

4.2 These methods are considered satisfactory for acceptance testing of commercial shipments because the methods have been used extensively in the trade for this purpose, and because estimates of current between-laboratory precision are acceptable in most cases.

4.2.1 If there are differences of practical significance between reported test results for two laboratories (or more), comparative test should be performed to determine if there is a statistical bias between them, using competent statistical assistance. As a minimum, the test samples should be used that are as homogeneous as possible, that are drawn from the material from which the disparate test results were obtained, and that are randomly assigned in equal numbers to each laboratory for testing. Other materials with established test values may be used for this purpose. The test results from the two laboratories

³ Available from Standardization Documents Order Desk, Bldg. 4 Section D, 700 Robbins Ave., Philadelphia, PA 19111-5094, Attn: NPODS.

should be compared using a statistical test for unpaired data, at a probability level chosen prior to the testing series. If a bias is found, either its cause must be found and corrected, or future test results must be adjusted in consideration of the known bias.

4.3 The method(s) in the standard along with those in Test Methods D 2051, D 2052, D 2053, D 2054, D 2057, D 2058, D 2059, D 2060, and D 2062 are a collection of proven test methods. They can be used as aids in the evaluation of zippers without the need for a thorough knowledge of zippers. The enumerated test methods do not provide for the evaluation of all zipper properties. Besides those properties measured by means of the enumerated test methods there are other properties that may be important for the satisfactory performance of a zipper. Test methods for measuring those properties have not been published either because no practical methods have yet been developed or because a valid evaluation of the information resulting from existing unpublished methods requires an intimate and thorough knowledge of zippers.

5. Sampling

5.1 *Lot Sample*—As a lot sample for acceptance testing, take at random the number of individual containers from each shipping carton as directed in an applicable material specification or other agreement between the purchaser and the supplier. Consider individual containers from each shipping carton to be the primary sampling units.

NOTE 1—An adequate specification or other agreement between the purchaser and supplier requires taking into account the variability between shipping cartons and between zippers in a container to provide a sampling plan with a meaningful producer’s risk, consumer’s risk, acceptable quality level, and limiting quality level.

5.2 *Laboratory Sample and Test Specimens*—As a laboratory sample for acceptance testing, take the number of zippers specified in Section 6 at random from each container in the lot sample. Consider the zippers as both the laboratory sample and the test specimens.

6. Number of Specimens

6.1 *Variables*—Take a number of zippers per individual container from each shipping carton such that the user may expect at the 90 % probability level that the test result for an individual container is no more than 10 % of the average, above or below the true average for the individual container. Determine the number of zippers per individual container as follows:

6.1.1 *Reliable Estimate of v*—When there is a reliable estimate of *v* based upon extensive past records for similar materials tested in the users laboratory as directed in the method, calculate *n* using Eq 1.

$$n = t^2 \times v^2/A^2 = 0.0270 v^2 \tag{1}$$

where:

- n* = number of specimens (rounded upward to a whole number),
- v* = reliable estimate of the coefficient of variation of individual observations in the users laboratory under conditions of single-operation precision,
- t* = 1.645, the value of Student’s *t* for infinite degrees of freedom, two-sided limits and a 90 % probability level (*t*² = 2.706),
- A* = 10.0 % of the average, the value of the allowable variation, and
- 0.0270 = a value calculated from *t*²/*A*²

6.1.2 *No Reliable Estimate of v*—When there is no reliable estimate of *v* for the users laboratory, Eq 1 should not be used directly. Instead, specify the number of specimens shown in Table 1. This number of specimens is calculated using values of *v* which are somewhat larger values of *v* than are usually found in practice. When a reliable estimate of *v* for the users laboratory becomes available, Eq 1 will usually specify fewer than the number of specimens shown in Table 1.

6.2 *Attributes*—For methods for which the test result merely states whether there is conformance to the criteria for success specified in the procedure, take the number of specimens

TABLE 1 Specimens Required Under Conditions of Known and Unknown Variability in User’s Laboratory Units as Indicated

Property	Allowable Variation Two-Sided	Equation for <i>n</i> , Using a Reliable Estimate of <i>v</i>	No Reliable Estimate of <i>v</i>	
			Number of Specimens	Basis ^A
<i>Strength of chains and elements:</i>				
Chain crosswise strength	10.0	$n = 0.027 \times v^2$	2	<i>v</i> = 8.45
Element pull-off	10.0	$n = 0.027 \times v^2$	5	<i>v</i> = 12.56
Element slippage, lengthwise	10.0	$n = 0.027 \times v^2$	7	<i>v</i> = 14.97
<i>Holding strength of stops:</i>				
Top stop, holding	10.0	$n = 0.027 \times v^2$	17	<i>v</i> = 24.77
Bottom stop holding, slider	10.0	$n = 0.027 \times v^2$	22	<i>v</i> = 28.41
Bottom stop holding, crosswise	10.0	$n = 0.027 \times v^2$	8	<i>v</i> = 16.16
Bottom stop holding, stringer separation	10.0	$n = 0.027 \times v^2$	7	<i>v</i> = 15.60
Bridge top stop, stringer separation	10.0	$n = 0.027 \times v^2$	31	<i>v</i> = 33.75
<i>Holding strength of separable units:</i>				
Separable pin	10.0	$n = 0.027 \times v^2$	7	<i>v</i> = 15.46
Fixed retainer	10.0	$n = 0.027 \times v^2$	8	<i>v</i> = 16.34
Separating unit—crosswise	10.0	$n = 0.027 \times v^2$	4	<i>v</i> = 10.70
<i>Slider deflection and recovery:</i>				
mouth	10.0	$n = 0.027 \times v^2$	<i>B</i>	<i>v</i> = 93.11
pull	10.0	$n = 0.027 \times v^2$	<i>B</i>	<i>v</i> = 48.20
<i>Resistance to twist of pull and slider:</i>	10.0	$n = 0.027 \times v^2$	<i>B</i>	<i>v</i> = 51.4

^A The values of *v* in Table 1 are somewhat larger than will be usually found in practice (see 6.1.2).

^B No standard number of specimens is given for these tests since they are quite variable and are not recommended for acceptance testing except where the laboratories of the purchaser and the seller have established their precision and bias, if any.

directed in MIL Standard 105D for the level of inspection agreed upon by the purchaser and the seller. The methods to which these instructions apply are as follows:

	Sections
Resistance to Cushioned Compression of Sliders	30-38
Resistance to Pull-Off of Slider Pull	56-64
Resistance to Angular Pull-Off of Slider Pull	65-73
Holding Strength of Slider Lock	74-81

7. Test Specimen

7.1 The test specimen may consist of a completely assembled zipper, length of chain, or a component, as specified in the individual method.

8. Conditioning

8.1 Bring the specimens to moisture equilibrium for testing in the standard atmosphere for testing textiles as directed in Practice D 1776 unless otherwise specified (see 38.1, 48.1, 57.1, and 77.1). Preconditioning is not required for zippers other than those made of nylon.

STRENGTHS OF CHAINS AND ELEMENTS

9. Scope

9.1 These test methods cover the determination of the strengths of zipper chains and elements in tensile tests.

9.2 The element pull-off and element slippage tests apply to separate element zippers only.

10. Summary of Test Method

10.1 *Crosswise Strength*—The ability of a zipper chain to withstand lateral stress is measured by loading to destruction a 25.4-mm (1-in.) section of a specimen in a tensile testing machine equipped with clamps having special jaws.

10.2 *Element Pull-Off*—The gripping strength of a element around the bead is determined by pulling a single element from the bead at right angles to the stringer using a tensile testing machine fitted with a specially designed fixture.

10.3 *Element Slippage*—The ability of a element to resist longitudinal movement along the bead of the tape is determined with a tensile testing machine fitted with a specially designed fixture.

11. Significance and Use

11.1 *Crosswise Strength*—This test method may be used to determine crosswise strength which measures the resistance of a zipper to such failures as tape rupture, unmeshing, or element separation when the zipper is side stressed during use.

11.2 *Element Pull-off*—This test method may be used to determine element strength which measures a element’s ability to resist being fractured or pulled from the bead of the tape when the zipper is side stressed during use.

11.3 *Element Slippage*—This test method may be used to determine element attachment security and measures a element’s ability to remain on the tape bead in proper position to adjacent elements so that zipper operation can be maintained.

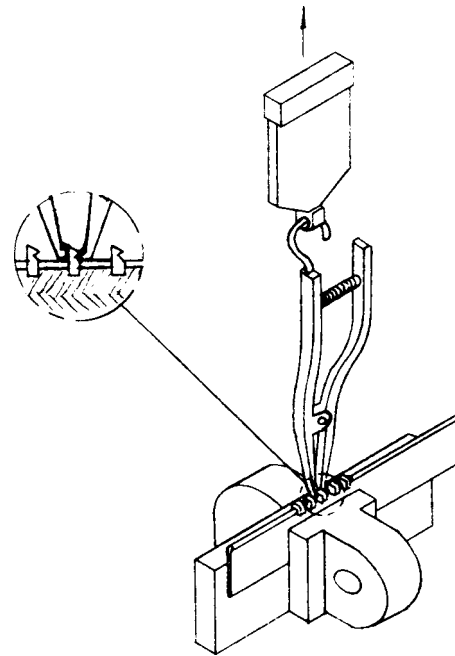

FIG. 1 Fixture for Element Pull-Off Test



FIG. 2 Fixture for Element Slippage Test

12. Apparatus

12.1 *Tensile Testing Machine*—A CRE type testing machine conforming to Specification D 76 with a rate-of-traverse of 305 ± 10 mm (12 ± 0.5 in.)/min. If preferred, the use of a CRT tensile testing machine is permitted. There may be no overall correlation between the results obtained with the CRE and CRT machines. Consequently, the two machines cannot be used interchangeably. In case of controversy, the CRE method shall prevail.

12.2 *Jaws*—The back jaws of the clamps on the tensile testing machine shall be at least the same width as the front jaws. The front jaws shall be 25.4 mm (1 in.) wide and have hardened faces with horizontal grooves 1.6 mm (1/16 in.) apart, 0.38 mm (0.015 in.) deep, and be of a V-shape with an included angle of 90°.

12.3 *Element Pull-off Fixture*,⁴ designed to grasp the head of the element by two members as shown in Fig. 1. The fixture must be designed to fit the element under test so as to avoid element distortion.

12.4 *Element Slippage Fixture*,⁴ consisting of a flat plate approximately 6 mm (1/4 in.) wide and 2 mm (1/16 in.) thick which is twisted 90° midway of its length and bent at one end through a 90° angle to give the fixture an “L” shape. The short leg of the “L” shall be slotted so that the two prongs thus formed will clear the bead and slip under a element in order to pull it along the bead as shown in Fig. 2.

13. Test Specimen

13.1 The test specimen shall consist of a completely assembled zipper or a piece of chain at least 127 mm (5 in.) long.

14. Procedure

14.1 *Chain Crosswise Strength*—Secure the tapes of the zipper or chain in the clamps of the tensile testing machine with the edges of the jaws parallel to the chain and approximately 3 mm (1/8 in.) from the outer edge of the interlockable elements or the outer edge of the beads if the bead extends beyond the elements. The ends of the front jaws shall be at least 25 mm (1 in.) from the slider, stops or end of the meshed chain. Apply an increasing load until the elements pull off the bead, until the tape separates, or until failure of some other kind occurs. Record the nature of the failure and the breaking load to the nearest 2.2 N (0.5 lbf).

14.2 *Element Pull-Off*—Secure the element pull-off fixture (Fig. 1) in the top clamp of the testing machine. Then adjust the fixture to grasp a single element on a stringer. Secure the stringer in the bottom clamp of the testing machine as described in 14.1. Apply an increasing load until the element is pulled off or other failure occurs. Record the nature of the failure and the load at failure to the nearest 0.4 N (0.1 lbf).

14.3 *Element Slippage, Lengthwise*—Remove an element from the stringer, taking care not to damage the bead. Cut through the bead and the tape under the bead in the center of the place where the element was removed. Cut the tape with a sharp razor blade, single stroke, ignoring blooming if it occurs. The element to be tested is the one just below the element that was removed. Secure the element slippage fixture (Fig. 2) in the top clamp and position the two prongs at the end of the short leg of the “L” in horizontal alignment underneath the element. Secure the stringer in the lower clamp of the testing machine in vertical alignment, positioning the clamps approximately 76 mm (3 in.) below the “L” of the fixture in the upper clamp. Apply an increasing load until the element slips off the

end of the cut bead or until other failure occurs. Record the nature of the failure and the load at failure to the nearest 0.4 N (0.1 lbf).

15. Report

15.1 State that the specimens were tested as directed in Sections 9-16 of Test Methods D 2061. Describe the material or product sampled and the method of sampling used.

15.2 Report the following information:

15.2.1 The specific property (or properties) evaluated,

15.2.2 Number and description of specimens tested, and

15.2.3 The observed values and nature of failures of each specimen.

16. Precision and Bias

16.1 *Interlaboratory Test Data*⁵—An interlaboratory test was run in which four laboratories each tested eight specimens, per operator, from each of two materials. Each laboratory used two operators to test each material. All 64 specimens of each material came from the same sample. The components of variance expressed as coefficients of variation, calculated as percentage of the average were:

	Single-Operator Component	Within-Laboratory Component ⁴	Between-Laboratory Component
Chain Crosswise Strength	6.04	0	4.82
Element Pull-Off	8.97	5.56	0
Element Slippage, Lengthwise	10.69	0	0

⁴ All the within laboratory component is attributable to the same operator testing at different times.

16.2 *Precision*—For the components of variance reported in 16.1, two averages of observed values should be considered significantly different at the 90 % probability level if the difference equals or exceeds the critical differences listed in Table 2.

NOTE 2—To convert the values in Table 2 to units of measure, multiply the average of the two specific sets of data being compared by the critical difference expressed as a decimal fraction.

NOTE 3—The tabulated values of the critical differences should be considered to be a general statement particularly with respect to between-laboratory precision. Before a meaningful statement can be made about two specific laboratories, the amount of statistical bias, if any, between them must be established with each comparison being based on recent data obtained on randomized specimens from one sample of the material to be tested.

16.3 *Bias*—No justifiable statement can be made on the bias of the procedures in Test Methods D 2061 for determining the strength of zipper chains and elements, since the true value of the properties cannot be established by an accepted referee method.

HOLDING STRENGTHS OF STOPS

17. Scope

17.1 These test procedures are used to determine the holding strengths of various types of zipper stops.

⁴ Drawings of the apparatus used in this test method are available from most zipper manufacturers upon request.

⁵ ASTM Research Report-No. D-13-1018. A copy is available from ASTM Headquarters, 100 Barr Harbor Drive, West Conshohocken, PA 19428.

TABLE 2 Critical Differences for the Properties Listed

	Number of Observations in Each Average	Critical Differences, Percent of Grand Average for the Conditions Noted		
		Single-Operator Precision	Within-Laboratory Precision	Between-Laboratory Precision
Chain Crosswise Strength	1	14.1	14.1	18.0
	3	8.1	8.1	13.8
	5	6.3	6.3	12.9
	10	4.4	4.4	12.1
Element Pull-off	1	20.9	24.5	24.5
	3	12.1	17.7	17.7
	5	9.3	15.9	15.9
	10	6.6	14.5	14.5
Element Slippage, Lengthwise	1	24.9	24.9	24.9
	3	14.4	14.4	14.4
	5	11.1	11.1	11.1
	10	7.9	7.9	7.9

18. Summary of Test Method

18.1 The ability of stops to perform their intended purpose is determined through the use of five different methods which simulate the important stresses encountered in the end use of zippers.

19. Significance and Use

19.1 *Top Stop Holding*—This test method may be used to determine top stop attachment strength which measures the ability of the top stop to prevent travel of the slider beyond the end of the chain.

19.2 *Bottom Stop Holding, Slider*—This test method may be used to determine bottom stop attachment strength, which measures the ability of the bottom stop to resist failure caused by stress applied longitudinally to the bottom stop through the slider.

19.3 *Bottom Stop Holding, Crosswise*—This test method may be used to determine bottom stop attachment strength, which measures the ability of the bottom stop to hold the two stringers of the chain together when the zipper is side stressed at the bottom stop.

19.4 *Bottom Stop Holding, Stringer Separation*—This test method may be used to determine bottom stop attachment strength, which measures the ability of the bottom stop to resist failure caused by such things as tape bead rupture, element separation from bead or bottom stop displacement due to stress applied through the stringers.

19.5 *Bridge Top Stop, Stringer Separation*—This test method may be used to determine bridge top stop attachment strength, which measures the ability of the bridge top stop to remain in place holding the stringers of a zipper together and limiting slider travel when the stop is stressed through the stringers.

20. Apparatus

20.1 *Testing Machine*, as specified in 12.1.

20.2 *Fixture*,⁴ with a curved end as shown in Fig. 3 to hook the pull of the slider.

21. Test Specimen

21.1 The test specimen shall consist of a completely assembled zipper.

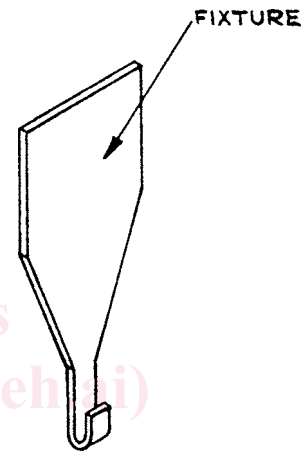

FIG. 3 Fixture for Test for Holding Strength of Top Stop

22. Procedure

22.1 In all tests, take care to prevent interference by any locking devices on the slider.

22.2 *Top Stop Holding*—Secure the fixture in the upper clamp of the testing machine and hook the pull of the slider on the fixture (Fig. 3). Position the slider body at the point where normally checked in its free movement by the stop or stops to be tested. Secure the zipper in the lower clamp of the testing machine as illustrated in Fig. 4. The distance between the top edge of the lower clamp and mouth of the slider shall be approximately 76 mm (3 in.). Apply an increasing load until the stop or stops pull off, until the tape breaks, or until failure of some other kind occurs. Record the nature of the failure and the load at failure to the nearest 2.2 N (0.5 lbf) for values under 222 N (50 lbf) and to the nearest 4.4 N (1 lbf) for values 222 N and over.

22.3 *Bottom Stop Holding, Slider*—Secure the fixture in the upper clamp of the testing machine and hook the pull of the slider on the fixture (Fig. 3). Position the slider at the point where normally checked in its free movement by the bottom stop to be tested. Secure the two stringers in the lower clamp of the testing machine as illustrated in Fig. 5, taking care to equalize the lengths of the two stringers between the clamps. The angle included between the stringers shall be such as to prevent the catching of elements on the flanges or on the diamond. The distance between the top edge of the lower

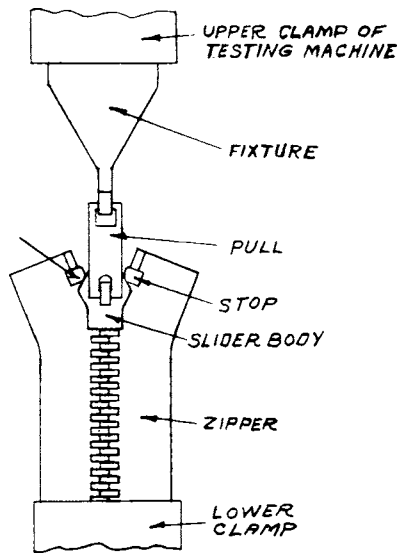

FIG. 4 Top Stop Holding Strength Test

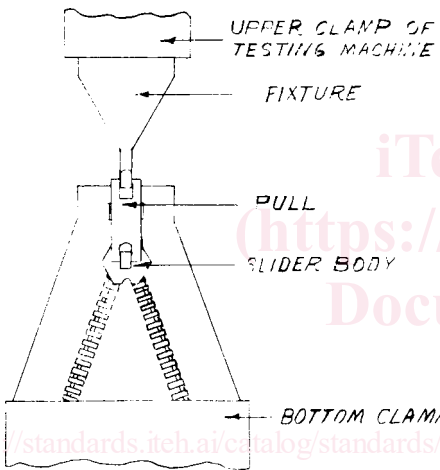

FIG. 5 Bottom Stop Holding Strength Test

clamp and the nearest surface of the slider body shall be approximately 76 mm (3 in.). Apply an increasing load until the stop pulls off, until the tape breaks, or until failure of some other kind occurs. Record the nature of the failure and the load at failure to the nearest 2.2 N (0.5 lbf) for values under 222 N (50 lbf) and to the nearest 4.4 N (1 lbf) for values 222 N and over.

22.4 *Bottom Stop Holding, Crosswise*—Remove the slider from the zipper. Open the chain by pulling the stringer apart all the way to the bottom stop. From both stringers remove the elements adjacent to but not under the bottom stop for a distance of approximately 13 mm (1/2 in.). Secure the tapes of the zipper in the clamps of the testing machine with the edges of the jaws parallel to and approximately 3 mm (1/8 in.) from the sides of the bottom stop, which shall be centrally located in the clamps as shown in Fig. 6. Apply the load until the stop pulls apart, until the tape breaks, or until failure of some other kind occurs. Record the nature of the failure and the load at failure to the nearest 2.2 N (0.5 lbf) for values under 222 N (50 lbf) and to the nearest 4.4 N (1 lbf) for values of 222 N and over.

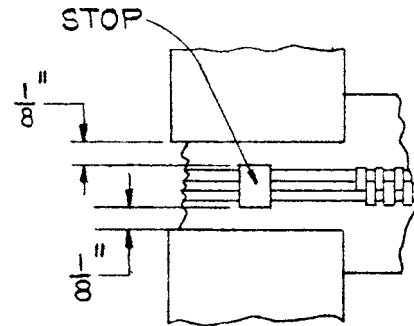

FIG. 6 Bottom Stop Holding, Crosswise Test

22.5 *Bottom Stop Holding, Stringer Separation*—Position the slider body so that its mouth is against the bottom of the stop to be tested. In the case of the entering type bottom stop, position the slider at the point where normally checked in its free movement. Set the opposing clamps of the testing machine approximately 76 mm (3 in.) apart and secure one of the stringers in the upper clamp and the other in the lower clamp of the tensile testing machine approximately 76 mm apart. Secure the stringers in the upper and lower clamps of the testing machine with the slider body positioned along the axis of the clamps and midway between them as shown in Fig. 7. Apply an increasing load until the stop pulls off, until the tape breaks, or until failure of some other kind occurs. Record the nature of the failure and load at failure to the nearest 2.2 N (0.5 lbf) for values under 222 N (50 lbf) and to the nearest 4.4 N (1 lbf) for values 222 N and over.

22.6 *Bridge Top Stop, Stringer Separation*—With the opposing clamps of the tensile testing machine set approximately 76 mm (3 in.) apart, separate the two stringers and secure them in the opposing clamps of the testing machine. Position the stop along the axis of the clamps and midway between them as shown in Fig. 8. Apply an increasing load until the stop pulls off, until the tape breaks, or until failure of some other kind occurs. Record the nature of the failure and the load at failure

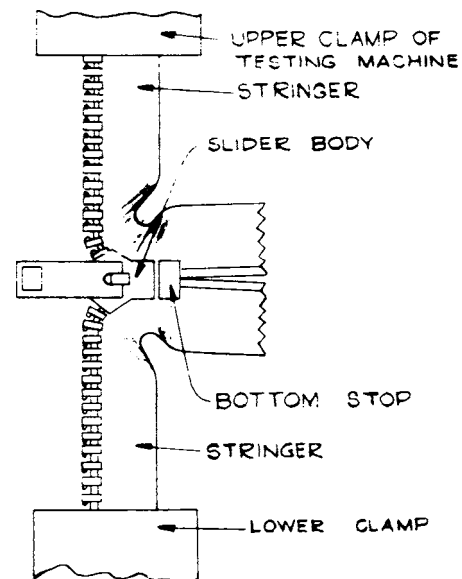

FIG. 7 Bottom Stop Holding, Stringer Separation Test