



SLOVENSKI STANDARD
kSIST-TS FprCEN/TS 16976:2016
01-april-2016

Zunanji zrak - Določevanje številčne koncentracije delcev atmosferskih aerosolov

Ambient air - Determination of the particle number concentration of atmospheric aerosol

Außenluft - Bestimmung der Partikelanzahlkonzentration des atmosphärischen Aerosols

Air ambiant - Détermination de la concentration en nombre de particules de l'aérosol atmosphérique

Ta slovenski standard je istoveten z: FprCEN/TS 16976

ICS:

13.040.20 Kakovost okoljskega zraka Ambient atmospheres

kSIST-TS FprCEN/TS 16976:2016 en,fr,de

TECHNICAL SPECIFICATION
SPÉCIFICATION TECHNIQUE
TECHNISCHE SPEZIFIKATION

FINAL DRAFT
FprCEN/TS 16976

February 2016

ICS 13.040.20

English Version

Ambient air - Determination of the particle number concentration of atmospheric aerosol

Air ambiant - Détermination de la concentration en nombre de particules de l'aérosol atmosphérique

Außenluft - Bestimmung der Partikelanzahlkonzentration des atmosphärischen Aerosols

This draft Technical Specification is submitted to CEN members for Vote. It has been drawn up by the Technical Committee CEN/TC 264.

CEN members are the national standards bodies of Austria, Belgium, Bulgaria, Croatia, Cyprus, Czech Republic, Denmark, Estonia, Finland, Former Yugoslav Republic of Macedonia, France, Germany, Greece, Hungary, Iceland, Ireland, Italy, Latvia, Lithuania, Luxembourg, Malta, Netherlands, Norway, Poland, Portugal, Romania, Slovakia, Slovenia, Spain, Sweden, Switzerland, Turkey and United Kingdom.

Recipients of this draft are invited to submit, with their comments, notification of any relevant patent rights of which they are aware and to provide supporting documentation.

Warning : This document is not a Technical Specification. It is distributed for review and comments. It is subject to change without notice and shall not be referred to as a Technical Specification.

<https://standards.iteh.ai/catalog/standards/sist/b15f7b8e-0930-4ccd-9e34-474a15c4b069/sist-ts-cen-ts-16976-2017>



EUROPEAN COMMITTEE FOR STANDARDIZATION
COMITÉ EUROPÉEN DE NORMALISATION
EUROPÄISCHES KOMITEE FÜR NORMUNG

CEN-CENELEC Management Centre: Avenue Marnix 17, B-1000 Brussels

Contents

Page

European Foreword.....	5
Introduction	6
1 Scope.....	7
2 Normative references.....	7
3 Terms and definitions	7
4 Atmospheric aerosol.....	9
5 Description of the method.....	9
5.1 Sampling and conditioning.....	9
5.1.1 Sampling.....	9
5.1.2 Drying.....	10
5.1.3 Dilution	11
5.2 Determination of the number concentration with a CPC	11
5.2.1 Condensation growth.....	11
5.2.2 Optical detection	13
6 CPC performance criteria and test procedures.....	14
6.1 General.....	14
6.2 General requirements of the CPC	14
6.3 Test conditions.....	15
6.4 Performance characteristics and criteria	15
6.5 Test procedures.....	16
6.5.1 Inlet flow rate accuracy.....	16
6.5.2 Number concentration measurement range.....	16
6.5.3 Number concentration detection limit.....	16
6.5.4 Linearity and slope of response.....	16
6.5.5 Detection efficiency curve at low particle size	17
6.5.6 Upper particle size detection limit	17
6.5.7 Zero count rate.....	17
6.5.8 Response time	17
6.5.9 Dependence of flow rate on supply voltage.....	17
6.5.10 Accuracy of temperature and pressure sensor calibration	17
6.5.11 Effect of failure of mains voltage	17
7 Performance criteria and test procedures for the sampling and conditioning system.....	18
7.1 General requirements	18
7.2 Performance characteristics and criteria	18
7.3 Diffusion losses	18
7.4 Relative humidity.....	18
7.5 Dilution factor	19
7.6 Primary sampling flow.....	19
8 Measurement procedure	19
8.1 Measurement planning.....	19
8.2 Environmental operating conditions.....	19

8.3	Initial installation	20
8.4	Initial checks on site	20
8.5	Data processing and reporting	20
9	Quality control, quality assurance and measurement uncertainty	21
9.1	General.....	21
9.2	Frequency of calibrations, checks and maintenance.....	21
9.2.1	General.....	21
9.2.2	Maintenance of CPC.....	21
9.2.3	Calibration of CPC plateau region and linearity	21
9.2.4	Determination of CPC low size cut-off.....	22
9.2.5	CPC zero check	22
9.2.6	Number concentration check	22
9.2.7	CPC flow rate calibration.....	22
9.2.8	Temperature and pressure sensor calibration.....	22
9.2.9	CPC internal diagnostics.....	23
9.2.10	Sample system maintenance	23
9.2.11	Relative humidity sensor	23
9.2.12	Dilution factor (where applicable).....	23
9.2.13	Leak check.....	23
9.3	Measurement uncertainty	23
9.3.1	General.....	23
9.3.2	CPC plateau detection efficiency	24
9.3.3	CPC detection efficiency drift.....	24
9.3.4	Flow determination	24
9.3.5	Correction to standard temperature and pressure.....	24
9.3.6	Sampling losses due to diffusion to walls.....	24
9.3.7	Dilution factor (where applicable).....	25
9.3.8	Calculation of overall uncertainty	25
Annex A (normative)	Determination of diffusion losses in sampling lines	26
Annex B (informative)	Example of the calculation of diffusion losses in a sampling system	28
B.1	Description of the sampling system.....	28
B.2	Air properties and diffusion coefficient	29
B.3	Losses in the primary sampling tube.....	29
B.4	Losses in the secondary sampling tube and the dryer	30
B.5	Overall sampling losses	30
Annex C (informative)	Data reporting.....	31
C.1	Motivation	31
C.2	Level 0 (annotated raw data)	32
C.3	Level 1 (data processed to final physical property, potential corrections applied, original temporal resolution)	32
C.4	Level 2 (hourly averages, including measures of variability)	32
C.5	GAW WDCA Condensation Particle Counter Level 0 (raw data) file format example (system without sample dilution):	34
C.6	Line-by-line explanations:.....	37
Annex D (informative)	Uncertainty calculation (example)	45

FprCEN/TS 16976:2016 (E)

D.1	General.....	45
D.2	CPC plateau detection efficiency.....	45
D.3	CPC detection efficiency drift.....	45
D.4	Flow determination.....	45
D.5	Correction to standard temperature and pressure	45
D.6	Sampling losses due to diffusion to walls.....	45
D.7	Dilution factor (where applicable)	46
D.8	Calculation of overall uncertainty.....	46
Annex E (informative) Atmospheric aerosols in Europe		47
E.1	General.....	47
E.2	Mean concentrations	47
E.3	Examples of measurements.....	48
Annex F (informative) Dilution systems.....		51
F.1	Background	51
F.2	Criteria for dilution systems	51
F.3	Operation principles of dilution systems.....	51
F.3.1	General.....	51
F.3.2	Dilution systems with partial flow filtration.....	52
F.3.3	Dilution systems with external clean air supply	52
Annex G (informative) Laminar flow.....		54
Bibliography.....		55

European Foreword

This document (FprCEN/TS 16976:2016) has been prepared by Technical Committee CEN/TC 264 “Air quality”, the secretariat of which is held by DIN.

This document is currently submitted to the Formal Vote.

iTeh STANDARD PREVIEW
(standards.iteh.ai)

[SIST-TS CEN/TS 16976:2017](https://standards.iteh.ai/catalog/standards/sist/b15f7b8e-0930-4ccd-9e34-474a15c4b069/sist-ts-cen-ts-16976-2017)

<https://standards.iteh.ai/catalog/standards/sist/b15f7b8e-0930-4ccd-9e34-474a15c4b069/sist-ts-cen-ts-16976-2017>

Introduction

There is a growing awareness of the significance of aerosol particles with diameters of $D < 1 \mu\text{m}$ for human health as well as for their climatic impact. To assess air quality, it appears necessary to supplement gravimetrically determined mass concentrations such as PM_{10} or $\text{PM}_{2.5}$ with a measurement of the particle number concentration. Since ultrafine particles with diameters of $D < 0,1 \mu\text{m}$ make an almost insignificant contribution to the mass of atmospheric aerosol particles, they can best be detected with counting measuring methods of sufficient sensitivity.

As particle measurement instrumentation allows determining either the particle number concentration or the particle number size distribution two Technical Specifications will be established:

- one dealing with the determination of the single parameter number concentration (a measure of “total” number concentration),
- one dealing with the determination of number concentration within a limited number of size ranges.

Clauses 5 and 6 contain general information about the method and the expected properties of the aerosol to be measured.

Clause 7 sets out the performance criteria for CPCs. Specifically, these are the relevant performance characteristics of CPC instruments (without any sampling system), the respective criteria that shall be met, and a description of how the tests shall be carried out. In general these tests are expected to be carried out by test houses or CPC manufacturers rather than users, and could form the basis for type approval of CPCs in future.

Clause 8 sets out the performance criteria and test procedures for the sampling and conditioning system (e.g. dilution). These may be applied by manufacturers of sampling systems, test houses or users (network operators).

Clause 9 sets out requirements for the installation, initial checks and calibrations, and operation of a CPC and sampling system at a monitoring site, including routine maintenance, data processing (including use of QA/QC data) and reporting. In general these will be the responsibility of users (network operators), though calibrations requiring test aerosols shall only be carried out by suitably qualified laboratories.

Clause 10 sets out Quality Assurance and Quality Control procedures, i.e. the ongoing checks and calibrations that are required on the CPC and sampling system during operation at a monitoring site. It is expected that these will be the responsibility of users (network operators), though calibrations requiring test aerosols shall only be carried out by suitably qualified laboratories. The main sources of measurement uncertainty are described, but it is not possible in this document to quantify the overall measurement uncertainty for data reported following the method.

1 Scope

This Technical Specification describes a standard method for determining the particle number concentration in ambient air in a range up to about 10^7 cm^{-3} for averaging times equal to or larger than 1 min. The standard method is based on a Condensation Particle Counter (CPC) operated in the counting mode and an appropriate dilution system for concentrations exceeding the counting mode range. It also defines the performance characteristics and the minimum requirements of the instruments to be used. The lower and upper sizes considered within this document are 7 nm and a few micrometres, respectively. This document describes sampling, operation, data processing and QA/QC procedures including calibration parameters.

2 Normative references

The following documents, in whole or in part, are normatively referenced in this document and are indispensable for its application. For dated references, only the edition cited applies. For undated references, the latest edition of the referenced document (including any amendments) applies.

ISO 27891, *Aerosol particle number concentration — Calibration of condensation particle counters*

3 Terms and definitions

For the purposes of this document, the following terms and definitions apply.

3.1 actual flow rate

volumetric flow rate of an individual instrument, measured at its inlet under the actual air conditions

Note 1 to entry: It is recommended that the actual flow rate be measured in regular intervals during operation.

3.2 aerosol

a multi-phase system of solid and/or liquid particles suspended in a gas, ranging in particle size from $0,001 \mu\text{m}$ to $100 \mu\text{m}$

3.3 calculation flow rate

flow rate which directly relates count rate and particle number concentration

Note 1 to entry: This flow rate is used for instrument internal calculation of the particle number concentration. It depends on the instrument type and may be nominal, factory-certified or actual inlet flow rate. It may also include a calibration factor unless the total inlet flow is analysed.

3.4 coincidence error

error that occurs with counting measuring methods when two or more particles are counted simultaneously as a single particle

Note 1 to entry: Coincidence error is related to particle number concentration, flow velocity through the sensing zone and size of sensing zone.

FprCEN/TS 16976:2016 (E)**3.5****detection efficiency**

ratio of the particle number concentration determined by the measuring instrument to the reference particle number concentration of the aerosol at the instrument's inlet

Note 1 to entry: The detection efficiency depends on particle size and may depend on particle number concentration.

3.6**factory-certified flow rate**

volumetric flow rate of an individual instrument at the time of factory calibration, measured at its inlet under the actual air conditions, and documented on a check out certificate

3.7**nominal flow rate**

volumetric flow rate indicated on the instrument specification sheet by the manufacturer

Note 1 to entry: The nominal flow rate is that flow rate, which a specific CPC model is designed for by the manufacturer. The real flow rate of individual instruments may differ from the nominal flow due to manufacturing tolerances.

3.8**number size distribution**

frequency distribution of the particle number concentration represented as a function of particle size

3.9**particle**

small piece of matter with defined physical boundary

Note 1 to entry: The phase of a particle can be solid, liquid, or between solid and liquid and a mixture of any of the phases.

[SOURCE: ISO 27891:2015, modified]

3.10**particle number concentration**

number of particles related to the unit volume of the carrier gas

Note 1 to entry: For the exact particle number concentration indication, information on the gaseous condition (temperature and pressure) or the reference to a standard volume indication is necessary.

[SOURCE: ISO 27891:2015]

4 Atmospheric aerosol

Atmospheric aerosols are strongly dependent on their local and regional sources. Especially, the size distribution in number and mass, as well as the size-resolved chemical composition are highly variable. Aerosol particles are either emitted directly (primary aerosols) or formed by nucleation and condensation from pre-cursor gases (secondary aerosol). Combustion processes lead to both primary and secondary aerosols.

Mass-wise, the global direct emission of aerosol particles is dominated by sea salt, biological material as well as by desert and volcanic dust. These particles are generally larger than 1 μm . Anthropogenic emissions in this size range play a minor role on a global scale. Submicrometer natural aerosols consist mainly of marine sulfate, biogenic organics, and wildfire carbonaceous particles. Submicrometer anthropogenic aerosols are complex mixtures of primary and secondary particles, consisting mainly of sulfate, nitrate, organics and elemental carbon.

Particle number concentrations of atmospheric aerosols cover several orders of magnitude. While remote marine or free tropospheric aerosols have number concentrations as low as tens or a few hundred per cubic centimetre, anthropogenically influenced aerosols can contain a few thousand up to one million particles per cubic centimetre. The number concentration of the anthropogenic aerosol over land, especially in urban areas is dominated by particles in the size range smaller than 0,1 μm . Major sources for high number concentrations in this size range are regional new particle formation and local combustion processes. Average background concentrations in an urban area are several tens of thousands of particles per cubic centimetre.

For details see Annex E.

5 Description of the method

5.1 Sampling and conditioning

5.1.1 Sampling

The measurement of atmospheric aerosols will always necessitate sampling and the transport of the sample to the measuring instrument. Moreover, in certain cases the sample has to be processed in terms of temperature, relative humidity and particle concentration in order to adapt the aerosol to the measuring instrument's permissible operating conditions.

The information given on this issue in this document refers to stationary ambient monitoring sites. For mobile applications (e.g. measurements from aircraft), additional considerations have to be taken into account.

The measuring instruments shall be accommodated in a protected environment in controlled conditions (temperature 15 $^{\circ}\text{C}$ to 30 $^{\circ}\text{C}$).

The sampling location depends on the measurement task. If the undisturbed atmospheric aerosol is to be measured, air intake should take place 5 m to 10 m above the ground level. Buildings, vegetation or the topography of the terrain may make an even higher sampling point necessary. By contrast, the measurement of aerosols close to the source (e.g. traffic) calls for much lower sampling points (1,5 m to 4 m above the ground, see Directive 2008/50/EC [1]).

The design of the intake port should permit representative sampling regardless of the direction of the wind for a broad range of wind velocities. However, this is not a critical condition for the small particles measured by the CPC. Steps shall be taken to avoid soiling of the sampling lines by particles larger than 10 μm . For this purpose a PM10 or PM2.5 inlet can be used (see Figure 1).

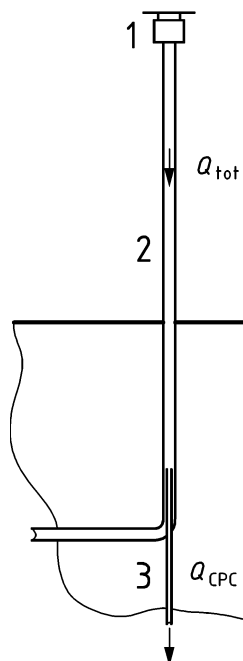
**Key**

- 1 PM sampling inlet
- 2 Primary sampling tube
- 3 Secondary sampling tube

Figure 1 — Basic design of the aerosol intake port

The sample should ideally be fed via a vertical primary sampling tube without bends to the measuring instruments. Since gas measuring methods have fundamentally different requirements regarding sampling, gas and aerosol sampling should be conducted independently of each other.

To reduce diffusion loss, it is necessary to intake aerosol with the aid of a pump at a primary flow rate (Q_{tot}) much higher than the secondary flow rate (Q_{CPC}). The CPC should sample isoaxially in the central area from this volumetric flow via a secondary sampling tube that is as short as possible. Flow in the primary sampling tube should be laminar in order to prevent additional particle loss due to turbulence. Ideally, a Reynolds number of about $Re = 2000$ shall be aimed for (see 7.2).

The diffusion losses in the sampling system for smallest relevant particle size of 7 nm shall be less than 30 % (see 7.2).

The intake port and lines shall be made of a conductive, corrosion-resistant material with a low surface roughness (e.g. stainless steel) and electrically earthed. This prevents chemical changes to the aerosol and particle losses due to electrostatic effects. Flexible tubing of electrically conductive material may also be used for small connections or short distances. The length of flexible tubing should be below 50 cm.

The inlet and the flow-splitter of the sampling system shall be checked regularly to detect obstructions, e.g. by insects, and cleaned, if necessary.

5.1.2 Drying

Aerosols with a high relative humidity (mist in extreme cases) should be dried, as the size of particles of hygroscopic materials is strongly influenced by humidity. The requirement is to keep the relative humidity of the primary flow at the CPC inlet lower than 40 % (see 7.2). The relative humidity at the inlet of the CPC shall be monitored.

With respect to the temperature conditions three cases are to be distinguished:

- In case the room temperature is higher than 22 °C no aerosol dryer is needed if the ambient dew point temperature never exceeds 10 °C.
- If the dew point temperature is between 10 °C and the room temperature, the secondary flow shall be dried.
- In case that the dew point temperature is above the room temperature, the primary flow shall be dried before entering the room. Additional drying of the secondary flow may be necessary.

There are three recommended methods to dry the aerosol:

- Aerosol diffusion dryer based on silica;
- Membrane dryer (e.g. Nafion® dryer);
- Dilution with dry particle-free air (only for high concentrations, see 5.1.3). In this case the exact dilution ratio shall be known in order to calculate the correct concentrations.

NOTE Heating is not recommended as this may change the aerosol (significant evaporation of volatile components above 40 °C).

5.1.3 Dilution

Preferably the CPC selected to measure at any particular site will have a concentration range in counting mode (with or without coincidence correction) that covers the expected concentrations. When this is not possible or the CPC would rely on photometric mode the sample shall be diluted with particle-free air.

The dilution step may introduce a high uncertainty which shall be estimated and specified in the report. Where dilution is not required this step should be avoided.

The minimum requirement with respect to accuracy of the dilution factor is given in 7.2, operation principles of suitable dilution systems are presented in Annex F.

5.2 Determination of the number concentration with a CPC

5.2.1 Condensation growth

In a CPC, particles are enlarged by condensation growth and then subjected to optical detection by scattered light.

To incite the condensation growth of particles of a given diameter, a certain minimum saturation ratio with respect to a condensable vapour must be present in accordance with the Kelvin Formula (1):

$$S = \exp\left(\frac{4 \cdot \sigma \cdot M}{\rho \cdot R \cdot T \cdot d}\right) \quad (1)$$

Where

S is the saturation ratio (ratio of current vapour pressure to saturation vapour pressure);

σ is the surface tension of the vapour substance;

M is the molar mass of the vapour substance (relative molecular mass);

ρ is the density of the vapour substance in its condensed state;

R is the general gas constant;

FprCEN/TS 16976:2016 (E)

T is the absolute temperature;

d is the Kelvin equivalent diameter.

Particle shape, surface structure and affinity of the particle material to the vapour phase are important factors influencing the Kelvin equivalent diameter.

NOTE The Kelvin equivalent diameter (with respect to the vapour substance) of an aerosol particle is defined as the diameter of a pure vapour substance drop that would start to grow at the same supersaturation as the particle in question.

Figure 2 shows the principle of a continuous flow CPC. The aerosol enters a heated saturator (3) in which it is saturated with the vapour substance at a constant temperature. Typical vapour substances used in CPCs are alcohols, e.g. n-butanol. It then flows into a cooled condenser (6) where the vapour condenses on the particles forming spherical droplets that consist mainly of the vapour substance and have a diameter of typically a few micrometres. These particles can be easily detected and counted optically.

The temperatures of the saturator and the condenser are important operating parameters that influence the smallest detectable particle size.

iTeh STANDARD PREVIEW
(standards.iteh.ai)

SIST-TS CEN/TS 16976:2017

<https://standards.iteh.ai/catalog/standards/sist/b15f7b8e-0930-4ccd-9e34-474a15c4b069/sist-ts-cen-ts-16976-2017>

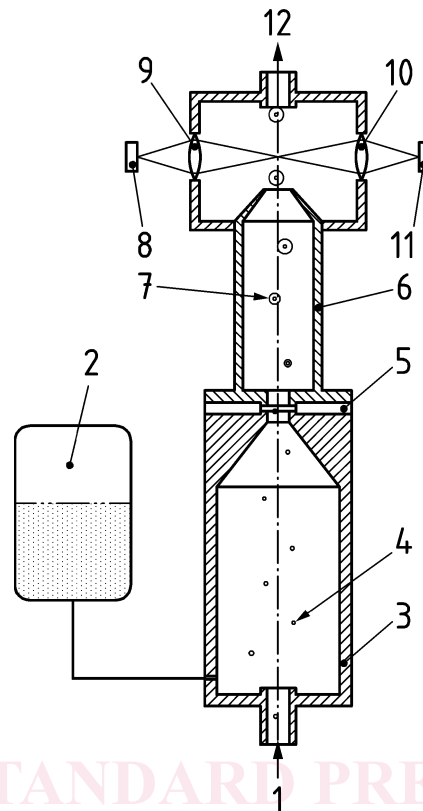

iTeh STANDARD PREVIEW
(standards.iteh.ai)

Key

- 1 Aerosol inlet
- 2 Vapour substance reservoir
- 3 Heated saturator
- 4 Nanoparticle (not true to scale)
- 5 Thermoelectric cooling and heating device
- 6 Condenser
- 7 Droplet (not true to scale)
- 8 Light source
- 9 Illumination optics
- 10 Receiving optics
- 11 Photodetector
- 12 Aerosol outlet

Figure 2 — Principle of a continuous flow CPC (see ISO 27891)

5.2.2 Optical detection

The droplets produced by the condensation process are then transported through a light beam. The light scattered by the droplets is collected by a receiving optic under a defined solid angle (receiver aperture) and guided onto a detector (e.g. photodiode). If the particle number concentration is low enough, the droplets cross the light beam one after the other, thus producing single electrical pulses at the detector output. From the count rate of these pulses and the calculation flow rate the total number concentration of the droplets can be determined. This number concentration is equal to the number concentration of the primary particles (condensation nuclei) with a size larger than the Kelvin diameter determined by the supersaturation achieved in the instrument.

For higher particle number concentrations more than one particle may cross the light beam at the same time (coincidence). This results in the coincidence error, which leads to a measured value lower than the actual concentration.