**Cardiac defibrillators — Connector
assembly DF-1 for implantable
defibrillators — Dimensions and test
requirements**

*Défibrillateurs cardiaques — Ensemble connecteur DF-1 pour défibrillateurs
implantables — Dimensions et exigences d'essai*

iTeh STANDARD PREVIEW
(standards.iteh.ai)

ISO 11318:2002

[https://standards.iteh.ai/catalog/standards/sist/a4ff6feb-6481-4073-9371-
c76b7a5f7a2f/iso-11318-2002](https://standards.iteh.ai/catalog/standards/sist/a4ff6feb-6481-4073-9371-c76b7a5f7a2f/iso-11318-2002)



PDF disclaimer

This PDF file may contain embedded typefaces. In accordance with Adobe's licensing policy, this file may be printed or viewed but shall not be edited unless the typefaces which are embedded are licensed to and installed on the computer performing the editing. In downloading this file, parties accept therein the responsibility of not infringing Adobe's licensing policy. The ISO Central Secretariat accepts no liability in this area.

Adobe is a trademark of Adobe Systems Incorporated.

Details of the software products used to create this PDF file can be found in the General Info relative to the file; the PDF-creation parameters were optimized for printing. Every care has been taken to ensure that the file is suitable for use by ISO member bodies. In the unlikely event that a problem relating to it is found, please inform the Central Secretariat at the address given below.

iTeh STANDARD PREVIEW
(standards.iteh.ai)

ISO 11318:2002

<https://standards.iteh.ai/catalog/standards/sist/a4ff6feb-6481-4073-9371-c76b7a5f7a2f/iso-11318-2002>

© ISO 2002

All rights reserved. Unless otherwise specified, no part of this publication may be reproduced or utilized in any form or by any means, electronic or mechanical, including photocopying and microfilm, without permission in writing from either ISO at the address below or ISO's member body in the country of the requester.

ISO copyright office
Case postale 56 • CH-1211 Geneva 20
Tel. + 41 22 749 01 11
Fax + 41 22 749 09 47
E-mail copyright@iso.ch
Web www.iso.ch

Printed in Switzerland

Contents

	Page
1 Scope	1
2 Normative reference	1
3 Terms and definitions	1
4 Requirements	2

Annexes

A Lead connector electrical isolation test.....	8
B Connector cavity current-carrying test	13
C Rationale for lead connector electrical isolation test.....	16
D Rationale for connector cavity current-carrying test.....	18
E Rationale for requirements of this International Standard.....	19

iTeh STANDARD PREVIEW
(standards.iteh.ai)

[ISO 11318:2002](https://standards.iteh.ai/catalog/standards/sist/a4ff6feb-6481-4073-9371-c76b7a5f7a2f/iso-11318-2002)

<https://standards.iteh.ai/catalog/standards/sist/a4ff6feb-6481-4073-9371-c76b7a5f7a2f/iso-11318-2002>

Foreword

ISO (the International Organization for Standardization) is a worldwide federation of national standards bodies (ISO member bodies). The work of preparing International Standards is normally carried out through ISO technical committees. Each member body interested in a subject for which a technical committee has been established has the right to be represented on that committee. International organizations, governmental and non-governmental, in liaison with ISO, also take part in the work. ISO collaborates closely with the International Electrotechnical Commission (IEC) on all matters of electrotechnical standardization.

International Standards are drafted in accordance with the rules given in the ISO/IEC Directives, Part 3.

Draft International Standards adopted by the technical committees are circulated to the member bodies for voting. Publication as an International Standard requires approval by at least 75 % of the member bodies casting a vote.

Attention is drawn to the possibility that some of the elements of this International Standard may be the subject of patent rights. ISO shall not be held responsible for identifying any or all such patent rights.

International Standard ISO 11318 was prepared by Technical Committee ISO/TC 150, *Implants for surgery*, Subcommittee SC 6, *Active implants*.

This second edition cancels and replaces the first edition (ISO 11318:1993), which has been technically revised.

Annexes A and B form a normative part of this International Standard. Annexes C, D and E are for information only.

ISO 11318:2002
<https://standards.iteh.ai/catalog/standards/sist/a4ff6feb-6481-4073-9371-c76b7a5f7a2f/iso-11318-2002>

Introduction

The purpose of this International Standard is to specify a standard connector assembly, DF-1, to provide interchangeability between implantable defibrillator leads and defibrillator pulse generators from different manufacturers. The safety, reliability and function of a particular connector part are the responsibility of the manufacturer.

Defibrillator connector systems not conforming to this International Standard may be safe and reliable, and may have clinical advantages.

iTeh STANDARD PREVIEW (standards.iteh.ai)

[ISO 11318:2002](https://standards.iteh.ai/catalog/standards/sist/a4ff6feb-6481-4073-9371-c76b7a5f7a2f/iso-11318-2002)

<https://standards.iteh.ai/catalog/standards/sist/a4ff6feb-6481-4073-9371-c76b7a5f7a2f/iso-11318-2002>

Cardiac defibrillators — Connector assembly DF-1 for implantable defibrillators — Dimensions and test requirements

1 Scope

This International Standard specifies a unipolar connector assembly, DF-1, intended for use in connecting implantable defibrillator leads to implantable defibrillator generators that do not produce more than 1 kV/50 A peak output. Essential dimensions and performance requirements related to connector fit are specified, along with test methods.

This International Standard does not specify other connector features such as fastening means and material. This International Standard is applicable to the form and fit of the connector assembly, and does not address all aspects of functional compatibility, system performance, or reliability of different implantable defibrillator leads and implantable defibrillator generator assemblies.

2 Normative reference

The following normative document contains provisions which, through reference in this text, constitute provisions of this International Standard. For dated references, subsequent amendments to, or revisions of, this publication do not apply. However, parties to agreements based on this International Standard are encouraged to investigate the possibility of applying the most recent edition of the normative document indicated below. For undated references, the latest edition of the normative document referred to applies. Members of ISO and IEC maintain registers of currently valid International Standards.

[ISO 11318:2002](https://standards.iteh.ai/catalog/standards/sist/a4ff6feb-6481-4073-9371-5f7a2fiso-11318-2002)

[https://standards.iteh.ai/catalog/standards/sist/a4ff6feb-6481-4073-9371-](https://standards.iteh.ai/catalog/standards/sist/a4ff6feb-6481-4073-9371-5f7a2fiso-11318-2002)

ISO 7436:1983, *Slotted set screws with cup point*

3 Terms and definitions

For the purposes of this International Standard, the following terms and definitions apply.

3.1

connector assembly

assembly, consisting of a lead connector and a connector cavity, for the electrical and mechanical connection to a defibrillator generator

3.2

lead connector

that part of the connector assembly that is inserted into the connector cavity

3.3

connector cavity

that part of the connector assembly that is part of the defibrillator generator

3.4

sealing mechanism

circumferential barrier intended to maintain the electrical insulation between electrically isolated parts of the connector assembly

3.5

seal zone

surface in the connector cavity and on the lead connector on which one or more seals are intended to bear

3.6
sealing mechanism zone
portion of the lead connector (and optionally the connector cavity) in which the sealing mechanism is permitted

3.7
connector cavity GO gauge
tool for assessing the ability of a connector cavity to accept a lead connector of maximum size

3.8
lead connector GO gauge
tool for assessing the ability of a lead connector to be inserted into a connector cavity of minimum size

3.9
lead connector pin
conductive element of the lead connector intended to contact the connector cavity conductive element

3.10
defibrillator system
assembly consisting of defibrillator generator and a defibrillator lead(s)

3.11
defibrillator lead
means of electrically connecting a defibrillator generator to the patient

3.12
defibrillator generator
portion of the defibrillator system that includes the power supply and electronic circuits

3.13
grip zone
area of lead connector that is provided for grasping the lead connector during insertion and withdrawal

3.14
connector contact
current-carrying interface between the connector cavity and the lead connector

4 Requirements

4.1 General

The test methods provided for the requirements that follow are type (qualification) tests. Equivalent test methods may be used. However, in the event of a dispute, the test methods described in this International Standard shall be used.

The tests shall be conducted at room temperature unless otherwise specified.

4.2 Defibrillator lead connector

4.2.1 Design requirements

4.2.1.1 Sealing mechanism

At least one seal shall be provided on the lead connector and shall be located as specified in Figure 1.

4.2.1.2 Dimensions

The lead connector shall have the dimensions specified in Figure 1.

Dimensions in millimetres

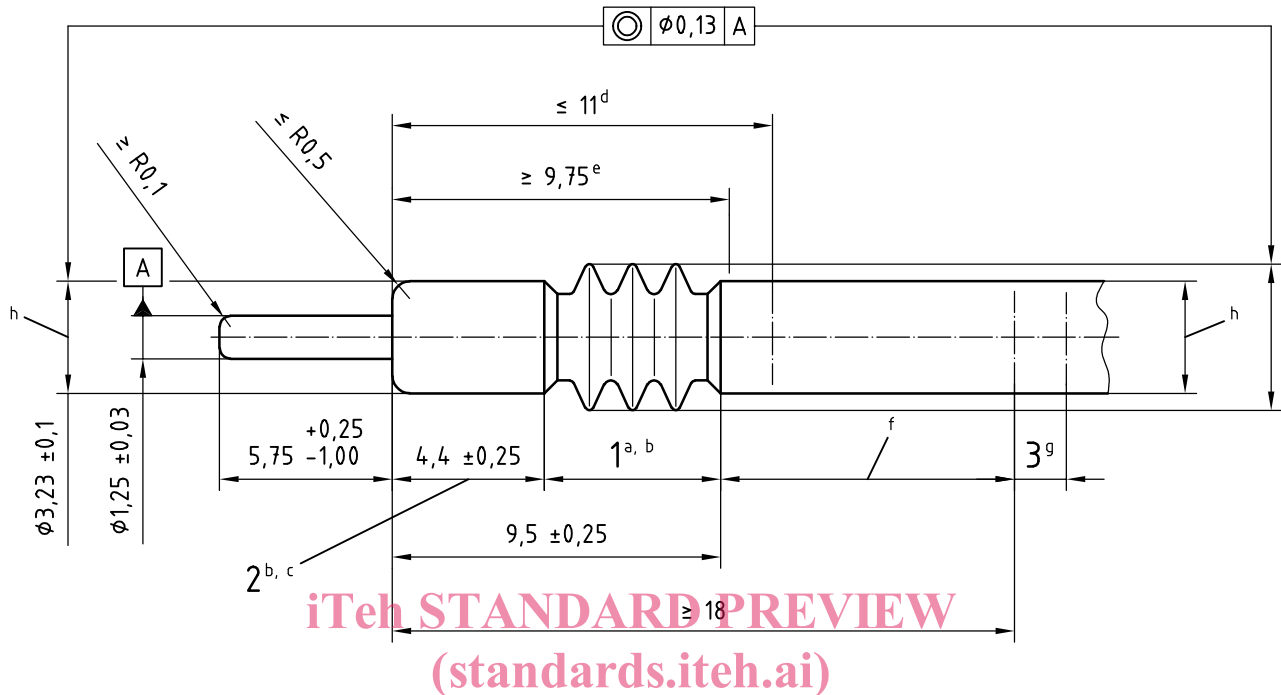

Key

- | | | |
|---|------------------------|---|
| 1 | Sealing mechanism zone | ISO 11318:2002 |
| 2 | Seal zone | https://standards.iteh.ai/catalog/standards/sist/a4ff6feb-6481-4073-9371-c76b7a5f7a2f/iso-11318-2002 |
| 3 | Grip zone | |
- a Sealing rings as shown are for illustration only and are not restricted as to shape, size or number.
- b The two diameters according to zone 1 and 2 shall be concentric within 0,13 mm to datum A.
- c For optional seal mechanism in connector cavity; $\phi 3,23 \pm 0,1$ applies to this zone.
- d Maximum length of rigid area.
- e Minimum length of rigid area.
- f $\phi 3,23^{+0,1}_{-0,2}$ applies to this zone only.
- g Length at the manufacturer's discretion, max. diameter 4,1 mm.
- h The diameters of the soft sections of the lead may be determined as the mean value of three measurements taken at locations oriented approximately 120° apart around the principal axis of the lead connector.

Figure 1 — DF-1 lead connector

4.2.2 Other requirements

4.2.2.1 Insertion and withdrawal forces

As shipped, the lead connector shall fit completely into the lead connector GO gauge specified in Figure 2. Neither the insertion force nor the withdrawal force shall exceed 14 N. After insertion and withdrawal, the lead connector shall comply with Figure 1.

Dimensions in millimetres
Surface roughness in micrometres

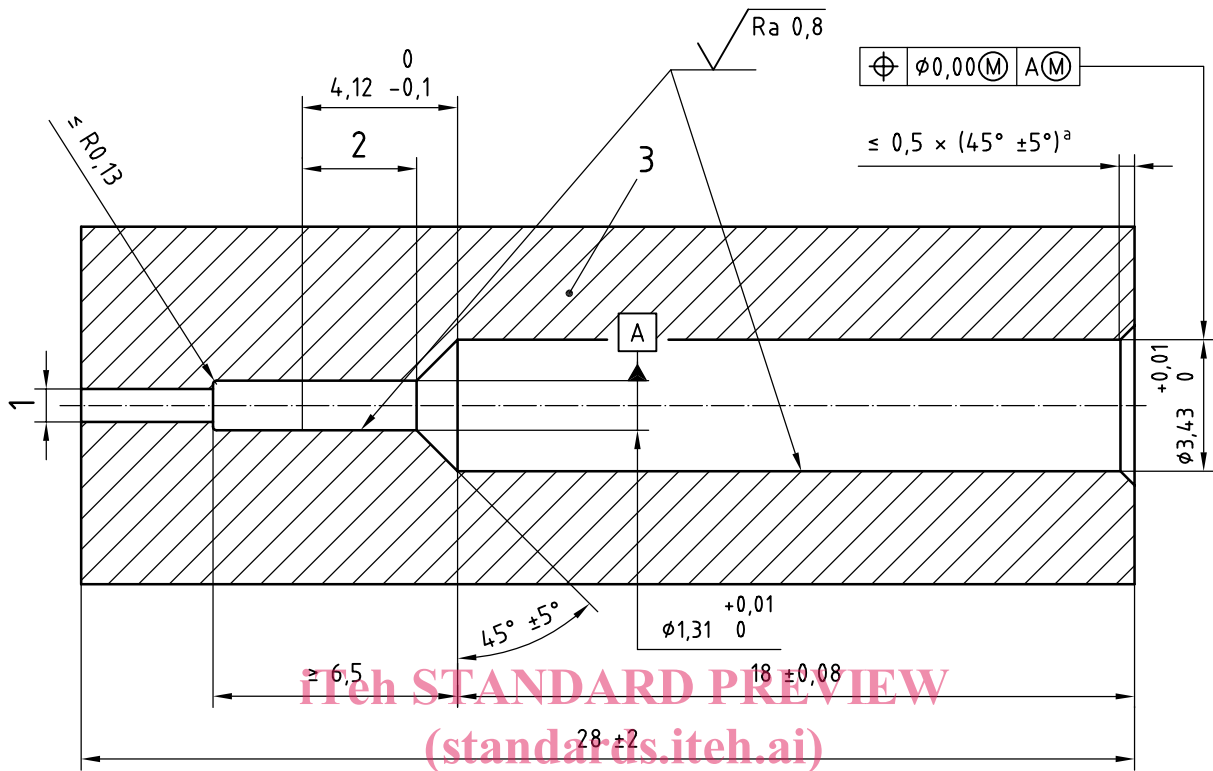

Key

- 1 Vent hole
- 2 Set-screw contact zone
- 3 Epoxy material
- ª Break sharp corners.

ISO 11318:2002
<https://standards.iteh.ai/catalog/standards/sist/a4ff6feb-6481-4073-9371-c76b7a5f7a2f/iso-11318-2002>

Figure 2 — DF-1 lead connector GO gauge

4.2.2.2 Deformation due to set-screw and grip zone forces

When tested as described below, the forces imposed by the securing mechanism shall not cause the lead connector to be deformed to the extent that it does not comply with 4.2.2.1.

Compliance shall be determined as follows.

Insert the lead connector into a lead connector GO gauge complying with Figure 2. Fasten the lead connector in the centre of zone 1 (see Figure 2) with an M2 setscrew with cup point complying with ISO 7436, applying a torque of $(0,15 \pm 0,01)$ N·m. Apply an axial withdrawal force of (15 ± 1) N for (60 ± 10) s to the grip zone and then retract the set-screw. Check that the lead connector still complies with 4.2.2.1.

4.2.2.3 Electrical isolation requirement

The lead connector shall provide electrical isolation between the lead connector pin and the surrounding fluid. Compliance shall be determined as described in annex A.

4.2.3 Marking

Marking shall be permanent and legible.

The lead connector shall be marked with the symbol “DF-1” as depicted in Figure 3.

DF-1

Figure 3 — Marking for defibrillator lead connector and generator

4.3 Defibrillator connector cavity

4.3.1 Design requirements

4.3.1.1 Optional seal mechanism

If provided, seal(s) shall be located at the zone specified in Figure 4 and shall provide electrical isolation. Compliance shall be determined as described in annex A.

4.3.1.2 Dimensions

The connector cavity dimensions shall be as specified in Figure 4.

iTeh STANDARD PREVIEW
(standards.iteh.ai)

4.3.2 Other requirements

[ISO 11318:2002](https://standards.iteh.ai/catalog/standards/sist/a4ff6feb-6481-4073-9371-c76b7a5f7a2f/iso-11318-2002)

4.3.2.1 Insertion and withdrawal forces

<https://standards.iteh.ai/catalog/standards/sist/a4ff6feb-6481-4073-9371-c76b7a5f7a2f/iso-11318-2002>

As shipped, the connector cavity shall accept the GO gauge specified in Figure 5. Neither the insertion force nor the withdrawal force shall exceed 9 N. After insertion and withdrawal, the connector cavity shall comply with Figure 4.

4.3.2.2 Current-carrying requirement

The connector contact shall be capable of carrying current. Compliance shall be determined as described in annex B.

4.3.3 Marking

The defibrillator generator shall be marked with the symbol “DF-1” as depicted in Figure 3.

Dimensions in millimetres unless otherwise indicated

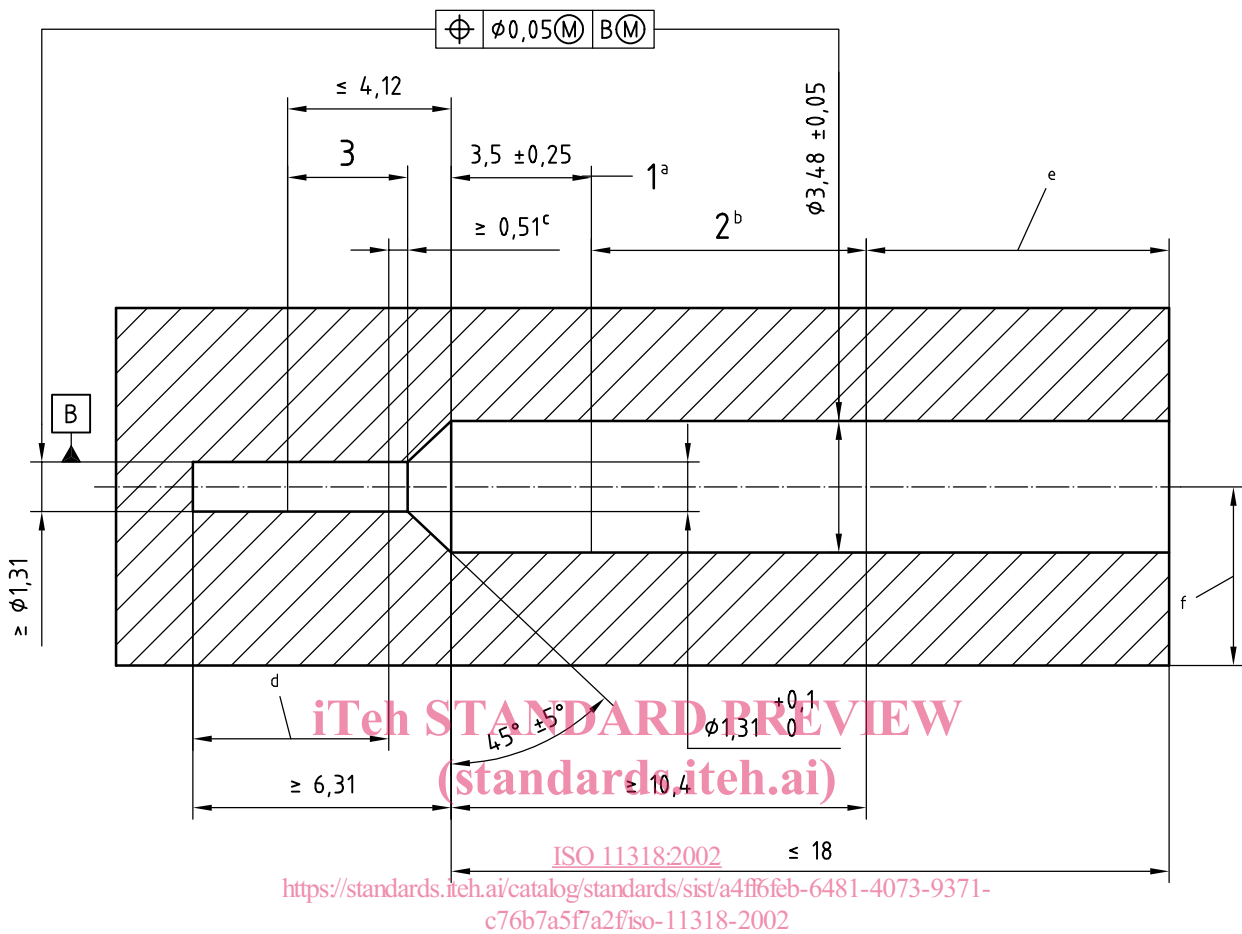

Key

- 1 Optional sealing mechanism zone
- 2 Seal zone
- 3 Lead connector pin contact zone
- ^a The diameter of this area shall meet the requirements of 4.3.2.1.
- ^b Specified diameter applies to this zone only.
- ^c $\phi 1,31^{+0,1}_0$ applies to this zone only.
- ^d $\phi 1,31$ min. applies to this zone only.
- ^e $\phi 3,43$ min. allowed in this zone.
- ^f The bore centreline shall be $\geq 2,05$ mm from the defibrillator generator at any point beyond the open end of the connector cavity.

Figure 4 — DF-1 connector cavity