Oprema za plamensko varjenje - Merjenje hrupa, ki ga oddaja gorilnik za varjenje, rezanje, segrevanje, trdo in mehko spajkanje - Merilna metoda

Gas welding equipment - Measurement of noise emitted by blowpipe for welding, cutting, heating, brazing and soldering - Measurement method

Gasschweißgeräte - Messungen für von Brennern für Schweißen, Schneiden, Wärmen, Hartlöten und Weichlöten erzeugte Geräusche - Messverfahren

Matériel de soudage aux gaz - Mesurage du bruit émis par les chalumeaux destinés au soudage, brasage, coupage et chauffage - Méthode de mesurage

<https://standards.iteh.ai/catalog/standards/sist/7a621e44-ca6a-4a04-92f5-3ecf21020a85/sist-tp-cen-tr-15068-2009>

Ta slovenski standard je istoveten z: CEN/TR 15068:2009

ICS:

17.140.20	Emisija hrupa naprav in opreme	Noise emitted by machines and equipment
25.160.30	Varilna oprema	Welding equipment

SIST-TP CEN/TR 15068:2009

en,fr

iTeh STANDARD PREVIEW
(standards.iteh.ai)

[SIST-TP CEN/TR 15068:2009](#)

<https://standards.iteh.ai/catalog/standards/sist/7a621e44-ca6a-4a04-92f5-3ecf21020a85/sist-tp-cen-tr-15068-2009>

TECHNICAL REPORT
RAPPORT TECHNIQUE
TECHNISCHER BERICHT

CEN/TR 15068

March 2009

ICS 25.160.30

English Version

**Gas welding equipment - Measurement of noise emitted by
blowpipe for welding, cutting, heating, brazing and soldering -
Measurement method**

Matériel de soudage aux gaz - Mesurage du bruit émis par
les chalumeaux destinés au soudage, brasage, coupage et
chauffage - Méthode de mesurage

Gasschweißgeräte - Messungen für von Brennern für
Schweißen, Schneiden, Wärmen, Hartlöten und Weichlöten
erzeugte Geräusche - Messverfahren

This Technical Report was approved by CEN on 17 February 2009. It has been drawn up by the Technical Committee CEN/TC 121.

CEN members are the national standards bodies of Austria, Belgium, Bulgaria, Cyprus, Czech Republic, Denmark, Estonia, Finland, France, Germany, Greece, Hungary, Iceland, Ireland, Italy, Latvia, Lithuania, Luxembourg, Malta, Netherlands, Norway, Poland, Portugal, Romania, Slovakia, Slovenia, Spain, Sweden, Switzerland and United Kingdom.

iTeh STANDARD PREVIEW
(standards.iteh.ai)

[SIST-TP CEN/TR 15068:2009](https://standards.iteh.ai/catalog/standards/sist/7a621e44-ca6a-4a04-92f5-3ecf21020a85/sist-tp-cen-tr-15068-2009)

<https://standards.iteh.ai/catalog/standards/sist/7a621e44-ca6a-4a04-92f5-3ecf21020a85/sist-tp-cen-tr-15068-2009>



EUROPEAN COMMITTEE FOR STANDARDIZATION
COMITÉ EUROPÉEN DE NORMALISATION
EUROPÄISCHES KOMITEE FÜR NORMUNG

Management Centre: Avenue Marnix 17, B-1000 Brussels

Contents		Page
Foreword.....		3
1	Scope	4
2	Normative references	4
3	Terms and definitions	4
4	Measurement conditions	4
5	Procedure	6
6	Test results	6
7	Test report	6

iTeh STANDARD PREVIEW
(standards.iteh.ai)

[SIST-TP CEN/TR 15068:2009](https://standards.iteh.ai/catalog/standards/sist/7a621e44-ca6a-4a04-92f5-3ecf21020a85/sist-tp-cen-tr-15068-2009)
<https://standards.iteh.ai/catalog/standards/sist/7a621e44-ca6a-4a04-92f5-3ecf21020a85/sist-tp-cen-tr-15068-2009>

Foreword

This document (CEN/TR 15068:2009) has been prepared by Technical Committee CEN/TC 121 "Welding", the secretariat of which is held by DIN.

Attention is drawn to the possibility that some of the elements of this document may be the subject of patent rights. CEN [and/or CENELEC] shall not be held responsible for identifying any or all such patent rights.

iTeh STANDARD PREVIEW (standards.iteh.ai)

[SIST-TP CEN/TR 15068:2009](https://standards.iteh.ai/catalog/standards/sist/7a621e44-ca6a-4a04-92f5-3ecf21020a85/sist-tp-cen-tr-15068-2009)

<https://standards.iteh.ai/catalog/standards/sist/7a621e44-ca6a-4a04-92f5-3ecf21020a85/sist-tp-cen-tr-15068-2009>

CEN/TR 15068:2009 (E)**1 Scope**

This Technical Report specifies a test method for measuring the noise emitted by manual blowpipes according to EN ISO 5172 used for welding, cutting and allied processes.

This test method is used only for comparative purposes between manual blowpipes when tested under nominal conditions under clause 5.

2 Normative references

The following referenced documents are indispensable for the application of this document. For dated references, only the edition cited applies. For undated references, the latest edition of the referenced document (including any amendments) applies.

EN 13622:2002, *Gas welding equipment — Terminology — Terms used for gas welding equipment*

EN 61260, *Electroacoustics — Octave-band and fractional-octave-band filters (IEC 61260:1995)*

EN 61672-1:2003, *Electroacoustics — Sound level meters — Part 1: Specifications (IEC 61672-1:2002)*

3 Terms and definitions

For the purposes of this document, the terms and definitions given in EN 13622:2002 and EN 61672-1:2003 apply.

iTeh STANDARD PREVIEW
(standards.iteh.ai)

4 Measurement conditions

[SIST-TP CEN/TR 15068:2009](https://standards.iteh.ai/catalog/standards/sist/7a621e44-ca6a-4a04-92f5-3ecf21020a85/sist-tp-cen-tr-15068-2009)

<https://standards.iteh.ai/catalog/standards/sist/7a621e44-ca6a-4a04-92f5-3ecf21020a85/sist-tp-cen-tr-15068-2009>

4.1 General

Measurement can be performed indoors only.

To measure the maximum emitted noise, the blowpipe under test is set in such a way that flame axis be horizontal, at least 1,5 m above the ground level, at least 1,5 m from the ceiling and at least at 5 m from the walls. Noise is measured for each type of nozzle which can be fitted on the blowpipe under nominal gas supply conditions indicated by the manufacturer. Microphone of sound level meter is placed at 1 m from the nozzle tip (see 4.4, Figure 1).

4.2 Measurement and correction of background noise

Measurements of background noises shall be performed in order to guarantee that measurements of noise emitted by blowpipes are not influenced by interferences. Background sound pressure level shall be lower than noise level emitted by the blowpipe and background together by more than 6 dB.

If difference of level is within 6 dB and 15 dB, calculate corrections of noise level according to Equation (1):

$$L_{pA} = 10 \lg(10^{L_{pA, sb}/10} - 10^{L_{pA, b}/10}) \text{dB} \quad (1)$$

where

L_{pA} is the corrected noise level emitted by the blowpipe, in decibels;

$L_{pA, sb}$ is the sound pressure level of the blowpipe and the background noise together, in decibels;

$L_{pA,b}$ is the background noise level.

If difference of level is greater than 15 dB, no correction is made.

4.3 Measuring equipment

4.3.1 Sound level meters and filters

Sound level meters in accordance with at least class 1 requirements of EN 61672-1 shall be used, with frequency weighting A and time constant S.

Another measurement equipment can be used, including for example a level recording device, providing that its global electroacoustical characteristics meets at least the requirements of EN 61672-1 class 1.

Octave-band filters, if they are used, shall meet the requirements for a class 1 instrument as given in EN 61260.

4.3.2 Pressure gauges and flowmeters

Pressure and flow measurements shall be performed at inlet of blowpipe to be tested.

Gauges which are used for the pressure measurements shall have an accuracy of $\pm 3\%$ regarding the indicated value or better. Flowmeters shall have an accuracy of $\pm 3\%$ regarding the indicated value of flow.

4.4 Measurement points for maximum emitted noise

Measurements are performed in the same horizontal plane as the blowpipe flame. Measurement locations are situated at 1 m from the nozzle tip. Six measurements are performed at locations defined by letters a to f in Figure 1.

[SIST-TP CEN/TR 15068:2009](https://standards.iteh.ai/catalog/standards/sist/7a621e44-ca6a-4a04-92f5-2022-cen-tr-15068-2009)

[https://standards.iteh.ai/catalog/standards/sist/7a621e44-ca6a-4a04-92f5-](https://standards.iteh.ai/catalog/standards/sist/7a621e44-ca6a-4a04-92f5-2022-cen-tr-15068-2009)

The measured sound pressure levels are denoted $L_{pA, \text{measured}, a}$ to $L_{pA, \text{measured}, f}$.

NOTE Maximum noise emitted by a blowpipe is situated just in front of the nozzle surface plane. Beyond an angle depending on the nozzle, noise decreases again.

Dimensions in millimetres

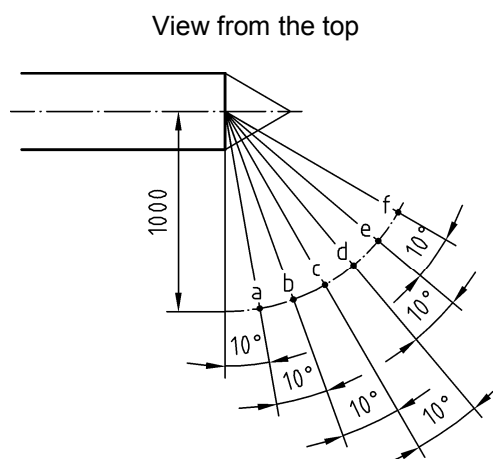

Figure 1 — Positions of the sensor of sound level meter

CEN/TR 15068:2009 (E)**5 Procedure**

The nominal gas supply conditions indicated by the manufacturer (gas type, pressure and flow rate) shall be applied to a blowpipe for each of its nozzles, if they are interchangeable. After the blowpipe is fitted in its test device, each nozzle is fitted one after another one, and measurement is performed according to conditions specified in Clause 4.

6 Test results

For each blowpipe/nozzle couple, the maximum value, of the six performed measurements, corrected if necessary (see 4.2), is retained as the A-weighted emission sound pressure level, $L_{pA\text{couple}}$.

7 Test report

Test report shall include at least the following indications:

- a) date of test;
- b) name and address of body which performed measurements;
- c) measurements conditions (location, device reference, possible corrections);
- d) sufficient identification of equipment [blowpipe, nozzle(s)] which has been tested;
- e) for each nozzle:
 - nominal supply conditions of blowpipe;
 - A-weighted emission sound pressure level, $L_{pA\text{couple}}$ (see Clause 6).
- f) reference to this standard.