



Designation: E 1569 – 03

Standard Test Method for Determination of Oxygen in Tantalum Powder¹

This standard is issued under the fixed designation E 1569; the number immediately following the designation indicates the year of original adoption or, in the case of revision, the year of last revision. A number in parentheses indicates the year of last reapproval. A superscript epsilon (ϵ) indicates an editorial change since the last revision or reapproval.

1. Scope

1.1 This test method covers the determination of oxygen in tantalum powder in concentrations from 0.05 to 0.50 %.

1.2 *This standard does not purport to address all of the safety problems, if any, associated with its use. It is the responsibility of the user of this standard to establish appropriate safety and health practices and determine the applicability of regulatory limitations prior to use.*

2. Referenced Documents

2.1 ASTM Standards:

E 29 Practice for Using Significant Digits in Test Data to Determine Conformance with Specifications²

E 50 Practices for Apparatus, Reagents, and Safety Precautions for Chemical Analysis of Metals³

E 691 Practice for Conducting an Interlaboratory Study to Determine the Precision of a Test Method²

3. Summary of Test Method

3.1 This test method is intended for use with automated, commercially available inert gas fusion analyzers.

3.2 The sample, plus flux, is fused in a graphite crucible under a flowing inert gas stream at a temperature sufficient to release oxygen. The released oxygen combines with carbon from the crucible to form CO that is swept by the inert gas stream into either an infrared or thermal conductivity detector. The detector output is compared to that of calibration reference materials and the result is displayed as percent oxygen.

3.3 In an instrument whose detection is based upon thermal conductivity (see Fig. 1), the sample gases are passed through heated rare earth copper oxide that converts CO to CO₂. The water produced during fusion is absorbed onto magnesium perchlorate and the remaining nitrogen and carbon dioxide are separated chromatographically. The nitrogen elutes first and can be measured (on a dual capability instrument) or disregarded. The oxygen, as CO₂, enters the measuring cell last and

¹ This test method is under the jurisdiction of ASTM Committee E01 on Analytical Chemistry for Metals, Ores, and Related Materials and is the direct responsibility of Subcommittee E01.06 on Ti, Zr, W, Mo, Ta, Nb, Hf.

Current edition approved June 10, 2003. Published August 2003. Last previous edition approved in 1998 as E 1569-93 (1998).

² *Annual Book of ASTM Standards*, Vol 14.02.

³ *Annual Book of ASTM Standards*, Vol 03.05.

the thermistor bridge output is integrated and processed to display percent oxygen.

3.4 In a typical instrument based on infrared detection (see Fig. 2), the sample is fused in a stream of argon and passed directly into an infrared cell through which infrared energy is transmitted. The CO in the sample gases absorbs some of the transmitted infrared energy and the decrease in energy reaching the detector is processed and displayed directly as percent oxygen.

4. Significance and Use

4.1 This test method is primarily intended as a test for compliance with compositional specifications. It is assumed that all who use this method will be trained analysts capable of performing common laboratory procedures skillfully and safely. It is expected that the work will be performed in a properly equipped laboratory.

5. Interferences

5.1 The elements usually present in this material do not interfere but there is some evidence to suggest that low-purity flux can act as a getter of the released oxygen.

6. Apparatus

6.1 *Fusion and Measurement Apparatus*—The general features of the instrument used in developing this test method are shown in Figs. 1 and 2.

6.2 *Capsules*—The capsules must be made of high-purity tin.

6.3 *Crucibles*—The crucibles must be made of high-purity graphite and be of the dimensions recommended by the manufacturer.

6.4 *Flux*—The foil or baskets must be made of high-purity nickel and in the case of the baskets, the dimensions must meet the requirements of the automatic sample drop, if present on the instrument.

6.5 *Tweezers*—Solvent and acid-resistant plastic.

7. Reagents

7.1 *Acetic Acid*—Reagent grade.

7.2 *Acetone*—Residue after evaporation must be less than 0.0005 %.

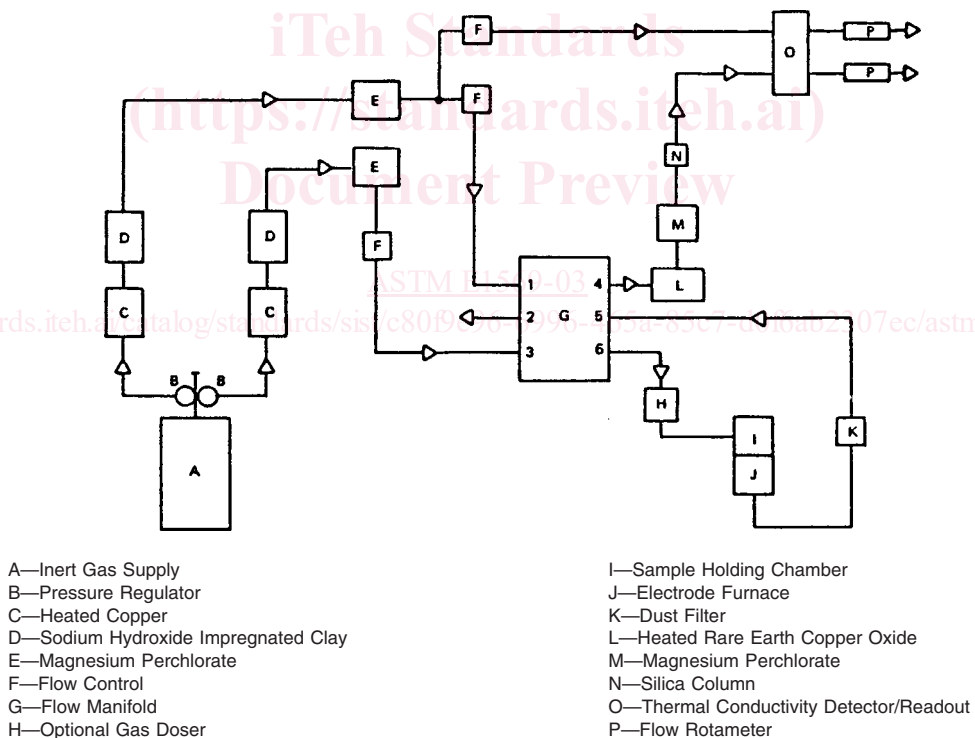
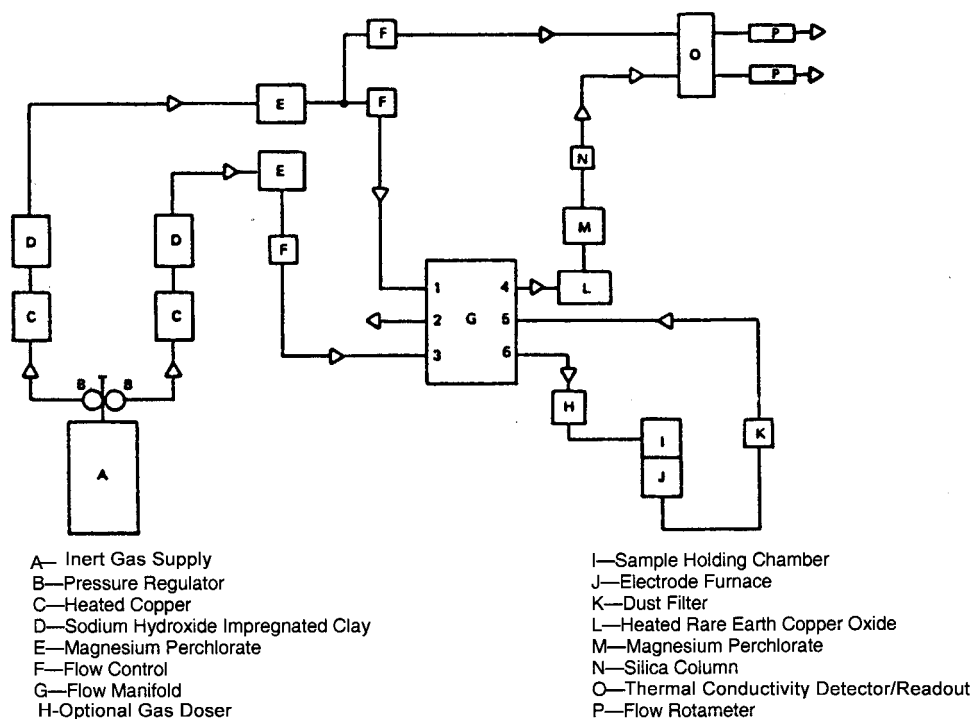

Manifold Porting	
Crucible Degas Flow	{ 1 to 4 5 to 2 3 to 6
Fusion Flow	{ 1 to 6 5 to 4 3 and 2 off

FIG. 1 Apparatus for the Determination of Oxygen by the Inert Gas Fusion—Thermal Conductivity Method