**Lasers and laser-related equipment —
Test methods for laser beam
parameters — Beam positional stability**

*Lasers et équipements associés aux lasers — Méthodes d'essai des
paramètres du faisceau laser — Stabilité de visée du faisceau*

iTeh STANDARD PREVIEW
(standards.iteh.ai)

ISO 11670:2003

<https://standards.iteh.ai/catalog/standards/sist/09d0ec85-3fe9-47b9-b984-0b4086b6d816/iso-11670-2003>



PDF disclaimer

This PDF file may contain embedded typefaces. In accordance with Adobe's licensing policy, this file may be printed or viewed but shall not be edited unless the typefaces which are embedded are licensed to and installed on the computer performing the editing. In downloading this file, parties accept therein the responsibility of not infringing Adobe's licensing policy. The ISO Central Secretariat accepts no liability in this area.

Adobe is a trademark of Adobe Systems Incorporated.

Details of the software products used to create this PDF file can be found in the General Info relative to the file; the PDF-creation parameters were optimized for printing. Every care has been taken to ensure that the file is suitable for use by ISO member bodies. In the unlikely event that a problem relating to it is found, please inform the Central Secretariat at the address given below.

iTeh STANDARD PREVIEW
(standards.iteh.ai)

[ISO 11670:2003](https://standards.iteh.ai/catalog/standards/sist/09d0ec85-3fe9-47b9-b984-0b4086b6d816/iso-11670-2003)

<https://standards.iteh.ai/catalog/standards/sist/09d0ec85-3fe9-47b9-b984-0b4086b6d816/iso-11670-2003>

© ISO 2003

All rights reserved. Unless otherwise specified, no part of this publication may be reproduced or utilized in any form or by any means, electronic or mechanical, including photocopying and microfilm, without permission in writing from either ISO at the address below or ISO's member body in the country of the requester.

ISO copyright office
Case postale 56 • CH-1211 Geneva 20
Tel. + 41 22 749 01 11
Fax + 41 22 749 09 47
E-mail copyright@iso.org
Web www.iso.org

Published in Switzerland

Contents	Page
1 Scope	1
2 Normative references	1
3 Terms and definitions	1
4 Coordinate systems and beam axis	3
4.1 Beam axis distribution	3
4.2 Coordinate systems	3
5 Test principles	5
5.1 Beam positional stability	5
5.2 Beam angular stability	5
6 Measurement arrangement, test equipment and auxiliary devices	5
6.1 Preparation	5
6.2 Control of environment	5
6.3 Detection system	6
6.4 Beam-forming optics, optical attenuators, beam splitters, focusing elements	6
6.5 Calibration	6
7 Test procedures	7
7.1 General	7
7.2 Beam positional stability	7
7.3 Beam angular stability	7
8 Evaluation	7
8.1 Beam positional stability	7
8.2 Beam angular stability	8
9 Test report	10
Annex A (informative) Propagation of absolute beam stability	12
Annex B (informative) Decoupling of short- and long-term fluctuations	15

Foreword

ISO (the International Organization for Standardization) is a worldwide federation of national standards bodies (ISO member bodies). The work of preparing International Standards is normally carried out through ISO technical committees. Each member body interested in a subject for which a technical committee has been established has the right to be represented on that committee. International organizations, governmental and non-governmental, in liaison with ISO, also take part in the work. ISO collaborates closely with the International Electrotechnical Commission (IEC) on all matters of electrotechnical standardization.

International Standards are drafted in accordance with the rules given in the ISO/IEC Directives, Part 2.

The main task of technical committees is to prepare International Standards. Draft International Standards adopted by the technical committees are circulated to the member bodies for voting. Publication as an International Standard requires approval by at least 75 % of the member bodies casting a vote.

Attention is drawn to the possibility that some of the elements of this document may be the subject of patent rights. ISO shall not be held responsible for identifying any or all such patent rights.

ISO 11670 was prepared by Technical Committee ISO/TC 172, *Optics and optical instruments*, Subcommittee SC 9, *Electro-optical systems*.

This second edition cancels and replaces the first edition (ISO 11670:1999), Clauses 3 and 9 of which have been technically revised. Annexes A and B have been added.

iTeh STANDARD PREVIEW
(standards.iteh.ai)
ISO 11670:2003
<https://standards.iteh.ai/catalog/standards/sist/09d0ec85-3fe9-47b9-b984-0b4086b6d816/iso-11670-2003>

Introduction

The centre of a laser beam is defined as the centroid or first-order spatial moment of the power density distribution. The current propagation axis of a beam is then the straight line connecting two centroids measured at two different planes simultaneously in a uniform, homogeneous medium. Beam axis instability may be characterized by transverse displacements and angular movements that are either monotonic, periodic or stochastic in time.

The movement of a laser beam may be randomly distributed and uniform in amplitude in all directions. In general, the beam may move a greater amount in one direction. If one direction predominates, the procedures specified in this International Standard can be used to identify that dominant direction (the beam x -axis) and its azimuthal location relative to the axes of the laboratory system.

This International Standard provides general principles for the measurement of these quantities. In addition, definitions of terminology and symbols to be used in referring to beam position are provided.

iTeh STANDARD PREVIEW (standards.iteh.ai)

[ISO 11670:2003](https://standards.iteh.ai/catalog/standards/sist/09d0ec85-3fe9-47b9-b984-0b4086b6d816/iso-11670-2003)

<https://standards.iteh.ai/catalog/standards/sist/09d0ec85-3fe9-47b9-b984-0b4086b6d816/iso-11670-2003>

iTeh STANDARD PREVIEW
(standards.iteh.ai)

ISO 11670:2003

<https://standards.iteh.ai/catalog/standards/sist/09d0ec85-3fe9-47b9-b984-0b4086b6d816/iso-11670-2003>

Lasers and laser-related equipment — Test methods for laser beam parameters — Beam positional stability

1 Scope

This International Standard specifies methods for determining laser beam positional as well as angular stability. The test methods given in this International Standard are intended to be used for the testing and characterization of lasers.

2 Normative references

The following referenced documents are indispensable for the application of this document. For dated references, only the edition cited applies. For undated references, the latest edition of the referenced document (including any amendments) applies.

ISO 11145:2001, *Optics and optical instruments — Lasers and laser-related equipment — Vocabulary and symbols*

ISO 11146:1999, *Lasers and laser-related equipment — Test methods for laser beam parameters — Beam widths, divergence angle and beam propagation factor*

IEC 61040:1990, *Power and energy measuring detectors, instruments and equipment for laser radiation*
<https://standards.iteh.ai/catalog/standards/sist/09d0ec85-3fe9-47b9-b984-0b4086b6d816/iso-11670-2003>

3 Terms and definitions

For the purposes of this document, the terms and definitions given in IEC 61040, ISO 11145 and ISO 11146 and the following apply.

3.1 angular movement

α_x, α_y

angular movement of the laser beam in the x - z and y - z planes, respectively

NOTE These quantities are defined in the beam axis system x, y, z . If the ratio of the quantity in the x direction to that in the y direction does not exceed 1,15:1, the quantity is regarded as rotationally symmetric and only one number may be given. The symbol α without index is used in that case.

3.2 beam angular stability

$\delta\alpha_x, \delta\alpha_y$

twice the standard deviation of the measured angular movement

NOTE These quantities are defined in the beam axis system x, y, z . If the ratio of the quantity in the x direction to that in the y direction does not exceed 1,15:1, the quantity is regarded as rotationally symmetric and only one number may be given. The symbol $\delta\alpha$ without index is used in that case.

3.3 pivot

point of intersection of all momentary beam axes with the z -axis

NOTE The measurement of the pivot is not a subject of this International Standard, because it does not necessarily exist.

**3.4
transverse displacement**

a_x, a_y

distance of transverse displacement of the laser beam in the x - and y -directions, respectively

NOTE 1 These quantities are defined in the beam axis system x, y, z . If the ratio of the quantity in the x direction to that in the y direction does not exceed 1,15:1, the quantity is regarded as rotationally symmetric and only one number may be given. The symbol a without index is used in that case.

NOTE 2 The measurement of the transverse displacement is not a subject of this International Standard.

**3.5
beam positional movement**

positional movement of the centroid of the laser beam in the plane z'

NOTE The positional movement at plane z' results from the superposition of transverse displacement and/or angular movement of the laser beam.

**3.6
beam positional stability**

$\Delta_x(z'), \Delta_y(z')$

four times the standard deviation of the measured beam positional movement at plane z'

NOTE These quantities are defined in the beam axis system x, y, z . If the ratio of the quantity in the x direction to that in the y direction does not exceed 1,15:1, the quantity is regarded as rotationally symmetric and only one number may be given. The symbol $\Delta(z')$ without index is used in that case.

Iteh STANDARD PREVIEW
(standards.iteh.ai)

**3.7
relative beam angular stability**

$\delta\alpha_{rel,x}, \delta\alpha_{rel,y}, \delta\alpha_{rel}$

beam angular stability divided by the divergence angle [ISO 11670:2003](https://standards.iteh.ai/catalog/standards/sist/09d0ec85-3fe9-47b9-b984-0b4086b6d816/iso-11670-2003)

[https://standards.iteh.ai/catalog/standards/sist/09d0ec85-3fe9-47b9-b984-](https://standards.iteh.ai/catalog/standards/sist/09d0ec85-3fe9-47b9-b984-0b4086b6d816/iso-11670-2003)

NOTE For elliptical beams, an effective divergence angle $\theta_{eff} = \sqrt{\frac{1}{2}(\theta_x^2 + \theta_y^2)}$ should be used, since the principal axes of the beam positional stability in general will not coincide with the principal axes of the laser beam propagation.

**3.8
relative beam positional stability**

$\Delta_{rel,x}(z'), \Delta_{rel,y}(z'), \Delta_{rel}(z')$

beam positional stability at plane z' divided by the beam diameter at plane z'

NOTE For elliptical beams, an effective beam diameter $d_{eff} = \sqrt{\frac{1}{2}(d_x^2 + d_y^2)}$ should be used, since the principal axes of the beam positional stability in general will not coincide with the principal axes of the laser beam propagation.

**3.9
beam stability parameter product**

S_x, S_y, S

The product of the minimum beam positional stability along the propagation and the beam angular stability

NOTE In a way similar to the beam diameter, the beam positional stability, as defined in sub-clause 3.6, obeys a hyperbolic propagation law. Thus, the propagation of the absolute beam stability can be completely characterized by three parameters: the position z_0 of the minimum value of the beam positional stability, the minimum value of the beam positional stability Δ_0 and the beam angular stability α . The position z_0 of the minimum value of the beam positional stability in general does not coincide with the waist position of the laser beam. See Annex A for further details.

**3.10
beam positional change from cold start**

difference in beam position from the position noted immediately upon turning on a turned-off, ambient-temperature-equilibrated laser and the position noted after that laser has operated for longer than the warm-up time

3.11 short-term stability
 stability within a time interval of 1 s

3.12 medium-term stability
 stability within a time interval of 1 min

3.13 long-term stability
 stability within a time interval of 1 h

4 Coordinate systems and beam axis

4.1 Beam axis distribution

The distribution of the beam axes (as defined in ISO 11145) is obtained from a significant number ($n \geq 1\ 000$) of measurements of the beam axis direction.

The movement of the beam axis can be described by means of the standard deviation of this beam axis distribution. This standard deviation can vary in different directions. This means that the amplitude of the beam movement can be greater in one dominant direction than in another, and that the distribution of beam axis movements is not necessarily radially symmetric.

iTeh STANDARD PREVIEW

4.2 Coordinate systems (standards.iteh.ai)

4.2.1 General

ISO 11670:2003

<https://standards.iteh.ai/catalog/standards/sist/09d0ec85-3fe9-47b9-b984->

All coordinate systems are defined as right-handed. iso-11670-2003

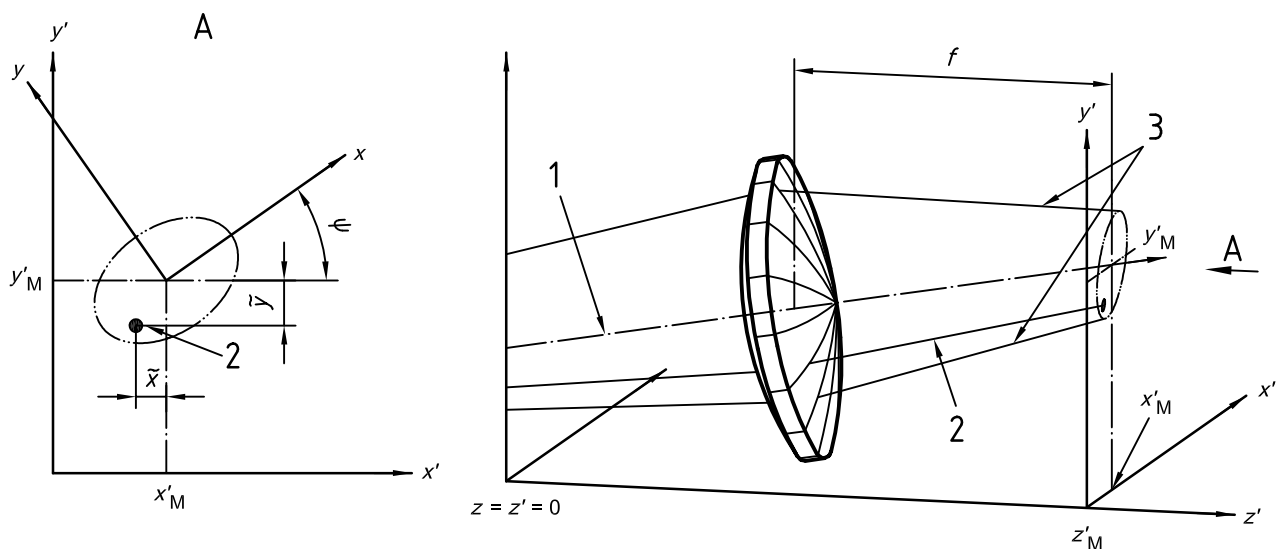

Key

- 1 average direction of the beam propagation axes
- 2 beam axis (for one measurement)
- 3 two times the standard deviation of the beam axis distribution

Figure 1 — Coordinate systems x',y',z' and x,y,z

4.2.2 Laboratory system

The x' , y' and z' axes define the orthogonal space directions in the laboratory system. The origin of the z' -axis is in a reference (x' - y')-plane defined by the laser manufacturer (e.g. the front of the laser enclosure), so that the beam propagates approximately (less than 10° deviation) along the z' -axis.

4.2.3 Beam axis system

A second orthogonal coordinate system, the beam axis system, is defined in the following way:

- the z -axis is the average direction of the beam propagation axis (first-order spatial moment of the beam axis distribution), which shall be determined after the laser has reached a steady state;
- the x -axis is the direction of maximum amplitude of movement of the asymmetric beam axis distribution in the far-field;

NOTE The asymmetric beam axis distribution is not to be confused with the asymmetric beam power distribution function.

- the origin of the beam axis system coincides with the origin of the laboratory system.

4.2.4 Azimuth angle

The azimuth angle, ψ , is the angle by which the beam x -axis is rotated with respect to the laboratory system x' -axis.

4.2.5 Transformation of coordinates

The transformation of the n measured coordinates of the laboratory system (x',y',z') into the beam axis system (x,y,z) shall be performed using the following equations for the translational and rotational transformations (see Figure 1, where subscript M indicates the coordinates in the measuring plane):

- a) First step (calculation of x'_M and y'_M)

$$x'_M = \frac{\sum_i x'_i}{n} \tag{1}$$

$$y'_M = \frac{\sum_i y'_i}{n} \tag{2}$$

where $i = 1$ to n .

- b) Second step (translation):

$$\tilde{x} = x' - x'_M \tag{3}$$

$$\tilde{y} = y' - y'_M \tag{4}$$

- c) Third step (rotation around the z axis):

$$\begin{pmatrix} x \\ y \end{pmatrix} = \begin{pmatrix} \cos\psi & \sin\psi \\ -\sin\psi & \cos\psi \end{pmatrix} \begin{pmatrix} \tilde{x} \\ \tilde{y} \end{pmatrix} \tag{5}$$

where

$$\psi = \frac{1}{2} \arctan \left(\frac{2s_{xy}^2}{s_x^2 - s_y^2} \right) \tag{6}$$

$$s_x^2 = \frac{\sum_i (x'_i - x'_M)^2}{n - 1} \tag{7}$$

$$s_y^2 = \frac{\sum_i (y'_i - y'_M)^2}{n - 1} \quad (8)$$

$$s_{xy}^2 = \frac{\sum_i (x'_i - x'_M)(y'_i - y'_M)}{n - 1} \quad (9)$$

where $i = 1$ to n .

5 Test principles

5.1 Beam positional stability

The beam positional stability is measured directly or in the image plane of an imaging element. The movement of the centroid of the beam is determined using a position-sensitive detector. The position of the centroid of the beam (as measured by the first-order spatial moment of the power density distribution function in the x, y, z system) indicates the instantaneous position of the beam axis in the laboratory x', y', z' system. The beam positional stability can be calculated from the standard deviation of the variation of the centroid position over the appropriate short, medium or long time scale.

5.2 Beam angular stability

The beam angular stability is measured in the focal plane of a focusing element. The movement of the centroid of the beam is determined using a position-sensitive detector. The position of the centroid of the beam (as measured by the first-order spatial moment of the power density distribution function in the x, y, z system) indicates the instantaneous direction of the beam axis in the laboratory x', y', z' system. The beam angular stability is calculated from the standard deviation of the variation of the centroid position over the appropriate short, medium or long time scale.

ISO 11670:2003

[https://standards.iteh.ai/catalog/standards/sist/09d0ec85-3fe9-47b9-b984-](https://standards.iteh.ai/catalog/standards/sist/09d0ec85-3fe9-47b9-b984-0b4086b6d816/iso-11670-2003)

[0b4086b6d816/iso-11670-2003](https://standards.iteh.ai/catalog/standards/sist/09d0ec85-3fe9-47b9-b984-0b4086b6d816/iso-11670-2003)

6 Measurement arrangement, test equipment and auxiliary devices

6.1 Preparation

The laser beam and the optical axis of the measuring system shall be coaxial.

The aperture of the optical system shall be such that it accommodates the entire cross-section of the laser beam. Clipping or diffraction loss shall contribute an increase of less than 1 % to the anticipated error of the final measurements. The optical elements (beam splitter, attenuator, imaging element, etc.) shall be mounted such that the optical axis runs through the geometrical centres. Care should be taken to avoid systematic errors. Reflections, external ambient and thermal radiation, air turbulence or thermal blooming are all potential sources of error.

The laser shall warm up according to the manufacturer's specification in order to achieve thermal equilibrium before measurements are started. The test equipment shall be in thermal equilibrium as well.

After the initial preparation is complete, an evaluation to determine if the entire laser beam reaches the detector surface shall be made. For testing this, apertures of different diameters can be introduced into the beam path in front of each optical component. The aperture which reduces the output signal by 5 % shall have a diameter less than 0,8 times the aperture of the optical component.

6.2 Control of environment

The optical bench or support system for the laser and measurement system should have an optomechanical stability that exceeds that of the laser under test by at least an order of magnitude. Measures should be taken to ensure that extraneous or systematic influences do not increase the anticipated probable error of the