



Designation: C 1327 – 03

## Standard Test Method for Vickers Indentation Hardness of Advanced Ceramics<sup>1</sup>

This standard is issued under the fixed designation C 1327; the number immediately following the designation indicates the year of original adoption or, in the case of revision, the year of last revision. A number in parentheses indicates the year of last reappraisal. A superscript epsilon ( $\epsilon$ ) indicates an editorial change since the last revision or reappraisal.

### 1. Scope

1.1 This test method covers the determination of the Vickers indentation hardness of advanced ceramics.

1.2 *This standard does not purport to address all of the safety concerns, if any, associated with its use. It is the responsibility of the user of this standard to establish appropriate safety and health practices and determine the applicability of regulatory limitations prior to use.*

### 2. Referenced Documents

2.1 *ASTM Standards:*<sup>2</sup>

- E 4 Practices for Force Verification of Testing Machines
- E 177 Practice for Use of the Terms Precision and Bias in ASTM Test Methods
- E 380 Practice for Use of the International System of Units (SI) (the Modernized Metric System)
- E 384 Test Method for Microhardness of Materials
- E 691 Practice for Conducting an Interlaboratory Study to Determine the Precision of a Test Method

2.2 *European Standard:*

CEN ENV 843-4 Advanced Technical Ceramics, Monolithic Ceramics, Mechanical Properties at Room Temperature, Part 4: Vickers, Knoop and Rockwell Superficial Hardness<sup>3</sup>

2.3 *Japanese Standard:*

JIS R 1610 Testing Method for Vickers Hardness of High Performance Ceramics<sup>4</sup>

2.4 *ISO Standard:*

ISO 6507/2 Metallic Materials—Hardness test—Vickers

test—Part 2: HV0.2 to less than HV5<sup>5</sup>

### 3. Terminology

3.1 Definition:

3.1.1 *Vickers hardness number (HV), n*—an expression of hardness obtained by dividing the force applied to a Vickers indenter by the surface area of the permanent impression made by the indenter.

3.1.2 *Vickers indenter, n*—a square-based pyramidal-shaped diamond indenter with face angles of 136° 00'.

### 4. Summary of Test Method

4.1 This test method describes an indentation hardness test using a calibrated machine to force a pointed, square base, pyramidal diamond indenter having specified face angles, under a predetermined load, into the surface of the material under test and to measure the surface-projected diagonals of the resulting impression after removal of the load.

NOTE 1—A general description of the Vickers indentation hardness test is given in Test Method E 384. The present method is very similar, has most of the same requirements, and differs only in areas required by the special nature of advanced ceramics. This test method also has many elements in common with standards ENV 843-4 and JIS R 1610, which are also for advanced ceramics.

### 5. Significance and Use

5.1 For advanced ceramics, Vickers indenters are used to create indentations whose surface-projected diagonals are measured with optical microscopes. The Vickers indenter creates a square impression from which two surface-projected diagonal lengths are measured. Vickers hardness is calculated from the ratio of the applied load to the area of contact of the four faces of the undeformed indenter. (In contrast, Knoop indenters are also used to measure hardness, but Knoop hardness is calculated from the ratio of the applied load to the projected area on the specimen surface.)

5.2 Vickers indentation hardness is one of many properties that is used to characterize advanced ceramics. Attempts have

<sup>1</sup> This test method is under the jurisdiction of ASTM Committee C28 on Advanced Ceramics and is the direct responsibility of Subcommittee C28.01 on Mechanical Properties and Performance.

Current edition approved Oct. 1, 2003. Published December 2003. Originally approved in 1996. Last previous edition approved in 1999 as C 1327 – 99.

<sup>2</sup> For referenced ASTM standards, visit the ASTM website, www.astm.org, or contact ASTM Customer Service at service@astm.org. For Annual Book of ASTM Standards volume information, refer to the standard's Document Summary page on the ASTM website.

<sup>3</sup> Available from European Committee for Standardization, Brussels, Belgium.

<sup>4</sup> Available from Japanese Standards Association, Tokyo, Japan.

<sup>5</sup> Available from International Standards Organization, Geneva, Switzerland.

been made to relate Vickers indentation hardness to other hardness scales, but no generally accepted methods are available. Such conversions are limited in scope and should be used with caution, except for special cases where a reliable basis for the conversion has been obtained by comparison tests.

5.3 Vickers indentation diagonal lengths are approximately 2.8 times shorter than the long diagonal of Knoop indentations, and the indentation depth is approximately 1.5 times deeper than Knoop indentations made at the same force.

5.4 Vickers indentations are influenced less by specimen surface flatness, parallelism, and surface finish than Knoop indentations, but these parameters must be considered nonetheless.

5.5 Vickers indentations are much more likely to cause cracks in advanced ceramics than Knoop indentations. The cracks may influence the measured hardness by fundamentally altering the deformation processes that contribute to the formation of an impression, and they may impair or preclude measurement of the diagonal lengths due to excessive damage at the indentation tips or sides.

5.6 A full hardness characterization includes measurements over a broad range of indentation forces. Vickers hardness of ceramics usually decreases with increasing indentation size or indentation force. The trend is known as the indentation size effect (ISE). Hardness approaches a plateau constant hardness at sufficiently large indentation size or forces. The test forces or loads that are needed to achieve a constant hardness vary with the ceramic. The test force specified in this standard is intended to be sufficiently large that hardness is either close to or on the plateau, but not so large as to introduce excessive cracking. A comprehensive characterization of the ISE is recommended but is beyond the scope of this test method, which measures hardness at a single, designated force.

## 6. Interferences

6.1 Cracking from the indentation tips can interfere with determination of tip location and thus the diagonal length measurements.

6.2 Cracking or spalling around the Vickers impression may occur and alter the shape and clarity of the indentation, especially for coarse-grained ceramics whereby grains may cleave and dislodge. The cracking may occur in a time-dependent manner (minutes or hours) after the impression is made.

6.3 Porosity (either on or just below the surface) may interfere with measuring Vickers hardness, especially if the indentation falls directly onto a large pore or if the indentation tip falls in a pore.

6.4 At higher magnifications in the optical microscope, it may be difficult to obtain a sharp contrast between the indentation tip and the polished surface of some advanced ceramics. This may be overcome by careful adjustment of the lighting as discussed in Test Method E 384.

## 7. Apparatus

### 7.1 Testing Machines:

7.1.1 There are two general types of machines available for making this test. One type is a self-contained unit built for this purpose, and the other type is an accessory available to existing

microscopes. Usually, this second type is fitted on an inverted-stage microscope. Descriptions of the various machines are available (1–3).<sup>6</sup>

7.1.2 Design of the machine should be such that the loading rate, dwell time, and applied load can be set within the limits set forth in 10.5. It is an advantage to eliminate the human element whenever possible by appropriate machine design. The machine should be designed so that vibrations induced at the beginning of a test will be damped out by the time the indenter touches the sample.

7.1.3 The calibration of the balance beam should be checked monthly or as needed. Indentations in standard reference materials may also be used to check calibration when needed.

### 7.2 Indenter:

7.2.1 The indenter shall meet the specifications for Vickers indenters. See Test Method E 384. The four edges formed by the four faces of the indenter shall be sharp. Chamfered edges (as in Ref (4)) are not permitted. The tip offset shall be not more than 0.5 μm in length.

7.2.2 Fig. 1 shows the indenter. The depth of the indentation is 1/3 the length of the diagonal. The indenter has an angle between opposite faces of 136° 0 min (±30 min).

7.2.3 The diamond should be examined periodically; and if it is loose in the mounting material, chipped, or cracked, it shall be replaced.

NOTE 2—This requirement is from Test Method E 384 and is especially pertinent to Vickers indenters used for advanced ceramics. Vickers indenters are often used at high loads in advanced ceramics in order to create cracks. Such usage can lead to indenter damage. The diamond indenter can be examined with a scanning electron microscope, or indents can be made into soft copper to help determine if a chip or crack is present.

### 7.3 Measuring Microscope:

7.3.1 The measurement system shall be constructed so that the length of the diagonals can be determined with errors not exceeding ± 0.0005 mm.

<sup>6</sup> The boldface numbers in parentheses refer to the list of references at the end of this test method.

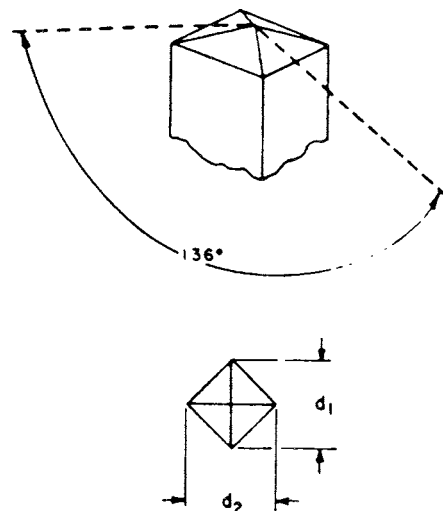

FIG. 1 Vickers Indenter

NOTE 3—Stage micrometers with uncertainties less than this should be used to establish calibration constants for the microscope. See Test Method E 384. Ordinary stage micrometers, which are intended for determining the approximate magnification of photographs, may be too coarsely ruled or may not have the required accuracy and precision.

7.3.2 The numerical aperture (NA) of the objective lens shall be between 0.60 and 0.90.

NOTE 4—The apparent length of a Vickers indentation will increase as the resolving power and NA of a lens increases. The variation is much less than that observed in Knoop indentations, however (2), (5), (6). The range of NA specified by this test method corresponds to 40 to 100× objective lenses. The higher power lenses may have higher resolution, but the contrast between the indentation tips and the polished surface may be less.

7.3.3 A filter may be used to provide monochromatic illumination. Green filters have proved to be useful.

## 8. Test Specimens

8.1 The Vickers indentation hardness test is adaptable to a wide variety of advanced ceramic specimens. In general, the accuracy of the test will depend on the smoothness of the surface and, whenever possible, ground and polished specimens should be used. The back of the specimen shall be fixed so that the specimen cannot rock or shift during the test.

8.1.1 *Thickness*—As long as the specimen is over ten times as thick as the indentation depth, the test will not be affected. In general, if specimens are at least 0.50 mm thick, the hardness will not be affected by variations in the thickness.

8.1.2 *Surface Finish*—Specimens should have a ground and polished surface. The roughness should be less than 0.1 μm rms. However, if one is investigating a surface coating or treatment, one cannot grind and polish the specimen.

NOTE 5—This requirement is necessary to ensure that the surface is flat and that the indentation is sharp. Residual stresses from polishing are of less concern for most advanced ceramics than for glasses or metals. References (7) and (8) report that surfaces prepared with 1 μm or finer diamond abrasive had no effect on measured ceramic hardness. Hardness was only affected when the surface finish had an optically resolvable amount of abrasive damage (7). (Extra caution may be appropriate during polishing of transformation toughening ceramics, such as some zirconias, since the effect upon hardness is not known.)

## 9. Preparation of Apparatus

9.1 *Verification of Load*—Most of the machines available for Vickers hardness testing use a loaded beam. This beam shall be tested for zero load. An indentation should not be visible with zero load, but the indenter should contact the sample. Methods of verifying the load application are given in Practices E 4.

9.2 *Separate Verification of Load, Indenter, and Measuring Microscope*—Procedures in Test Method E 384, Section 14, may be followed.

9.3 *Verification by Standard Reference Materials*—Standard reference blocks, SRM No. 2831, of tungsten carbide that are available from the National Institute of Standards and Technology<sup>7</sup> can be used to verify that an apparatus produces a Vickers hardness within ± 5 % of the certified value.

<sup>7</sup> National Institute of Standards and Technology, Standard Reference Materials Program, Gaithersburg, MD 20899.

## 10. Procedure

10.1 *Specimen Placement*—Place the specimen on the stage of the machine so that the specimen will not rock or shift during the measurement. The specimen surface shall be clean and free of any grease or film.

10.2 *Specimen Leveling*:

10.2.1 The surface of the specimen being tested shall lie in a plane normal to the axis of the indenter. The angle of the indenter and specimen surface should be within 2° of perpendicular.

NOTE 6—Greater amounts of tilting produce nonuniform indentations and invalid test results. 2° tilt will cause an asymmetrical indentation which is just noticeable, and will cause a 1 % error in hardness (9).

10.2.2 If one leg of a diagonal is noticeably longer than the other leg of the same diagonal, resulting in a deformed indentation, misalignment is probably present and should be corrected before proceeding with any measurements. See Test Method E 384.

10.2.3 Leveling the specimen is facilitated if one has a leveling device.<sup>8</sup>

10.3 *Magnitude of Test Force*—A test force of 9.81 N (1 kgf) is specified. If other forces are used because of a special requirement, or due to cracking problems at 9.81 N, then the reporting procedure of 12.6 shall be used. If additional forces are used (for example to measure the indentation size effect trend), then the reporting procedure of 12.6 shall be used for each data set.

NOTE 7—“Load” and “Force” are used interchangeably in this standard.

10.4 *Clean the Indenter*—The indenter shall be cleaned prior to and during a test series. A cotton swab with ethanol, methanol, or isopropanol may be used. Indenting into soft copper also may help remove debris.

NOTE 8—Ceramic powders or fragments from the ceramic test piece can adhere to the diamond indenter.

10.5 *Application of Test Load*:

10.5.1 Start the machine smoothly. The rate of indenter motion prior to contact with the specimen shall be 0.015 to 0.070 mm/s. If the machine is loaded by an electrical system or a dash-pot lever system, it should be mounted on shock absorbers which damp out all vibrations by the time the indenter touches the specimen.

NOTE 9—This rate of loading is consistent with Test Method E 384.

10.5.2 The time of application of the full test load shall be 15 s (±2) unless otherwise specified. After the indenter has been in contact with the specimen from this required dwell time, raise it carefully off the specimen to avoid a vibration impact.

10.5.3 The operator shall not bump or inadvertently contact the test machine or associated support (for example, the table) during the period of indenter contact with the specimen.

<sup>8</sup> The sole source of supply of the apparatus known to the committee at this time is the Tukon Tester leveling device, available from the Wilson Division of Instron Corp. If you are aware of alternative suppliers, please provide this information to ASTM Headquarters. Your comments will receive careful consideration at a meeting of the responsible technical committee, which you may attend.

10.6 *Spacing of Indentations*—Allow a distance of at least four diagonal lengths between the centers of the indentations as illustrated in Fig. 2. If there is cracking from the indentations, the spacing shall be increased to at least five times the length of the cracks, as shown in Fig. 2.

10.7 *Acceptability of Indentations:*

10.7.1 If there is excessive cracking from the indentation tips and sides, or the indentation is asymmetric, the indent shall be rejected for measurement. Fig. 3 provides guidance in this assessment. If the difference of the two diagonal lengths  $d_1$  and  $d_2$  is more than 5% of the mean value, the result shall be rejected and a check made of the parallelism and flatness of the test piece, and of the alignment of the indenter. If cracking occurs on most indentations, a lower indentation force (recommended 4.90 N) may be tried.

NOTE 10—If the indentations are still not acceptable, this test method shall not be used to measure hardness. It is recommended that hardness be evaluated by the Knoop hardness method.

10.7.2 If an indentation tip falls in a pore, the indentation shall be rejected. If the indentation lies in or on a large pore, the indent shall be rejected.

NOTE 11—In many ceramics, porosity may be small and finely distributed. The indentations will intersect some porosity. The measured hardness in such instances properly reflects a diminished hardness relative to the fully dense advanced ceramic. The intent of the restrictions in 10.6 is to rule out obviously unsatisfactory or atypical indentations for measurement purposes.

10.7.3 If the impression has an irregularity that indicates the indenter is chipped or cracked, the indent shall be rejected and the indenter shall be replaced.

10.8 In some materials, cracking around the indent may occur in a time dependent manner. If this occurs, the indentation size measurements specified in Section 11 should be made

as soon as is practical after the indentation is made. That is, each indent should be measured immediately after it is made (instead of making five or ten indentations and then measuring them).

10.9 *Location of Indentations*—Indentations shall be made in representative areas of the advanced ceramic microstructure. They shall not be restricted to high density regions if such regions exist.

10.10 *Number of Indentations*—For homogeneous and fully dense advanced ceramics, at least five and preferably ten acceptable indentations shall be made. If the ceramic is multiphase, not homogeneous, or not fully dense, ten acceptable indentations shall be made.

11. Measurement of Indentation Size

11.1 The accuracy of the test method depends to a very large extent on this measurement, since hardness depends upon the inverse square of the diagonal size.

11.1.1 If the measuring system contains a light source, take care to use the system only after it has reached equilibrium temperature. This is because the magnification of a microscope depends on the tube length.

11.1.2 Calibrate the measuring system carefully with an accurate and precision stage micrometer or with an optical grating.

11.1.3 Adjust the illumination and focusing conditions carefully as specified in Test Method E 384 to obtain the optimum view and clarity of the impression. Proper focus and illumination are critical for accurate and precise readings. Both indentation tips shall be in focus at the same time. Do not change the focus once the measurement of the diagonal length has begun.

NOTE 12—The lighting intensity and the settings of the field and aperture diaphragms can have a noticeable effect upon the apparent location of the tips in Vickers indentations. Consult the manufacturer’s guidelines for optimum procedures. Additional information is presented in Test Method E 384. In general, the field diaphragm can be closed so that it barely enters or just disappears from the field of view. The aperture diaphragm can be closed in order to reduce glare and sharpen the image, but it should not be closed so much as to cause diffraction that distorts the edges of the indentation.

NOTE 13—Uplift and curvature of the sides of the impressions may be substantial in impressions in advanced ceramics, which may cause the sides of the impression to be slightly out of focus. The tips of the impression shall be focused on for measurement of the indentation diagonals. It may be helpful to focus on a small microstructural feature on the flat specimen surface just beyond the indentation tips.

11.1.4 If either a measuring microscope or a filar micrometer eyepiece is used, always rotate the drum in the same direction to eliminate backlash errors.

11.1.5 Follow the manufacturer’s guidelines for the use of crosshairs or graduated lines. To eliminate the influence of the thickness of the line, always use the same edge of the crosshair or graduation line. **Caution**—Serious systematic errors can occur due to improper crosshair usage. Procedures vary considerably between different equipment. In nearly all instances, the crosshairs should not be placed entirely over or fully cover the indentation tip as shown in part (a) of Fig. 4. The indentation tip should be just visible in the fringe of light on the side of the crosshair or graduated line as shown in part (b) of

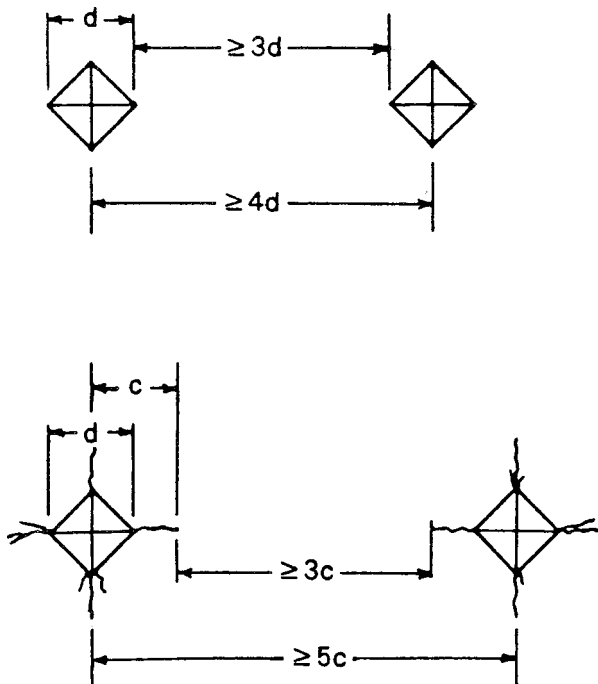

FIG. 2 Closest Permitted Spacing for Vickers Indentations