



SLOVENSKI STANDARD
SIST EN 13411-6:2004+A1:2008
01-december-2008

Zaključki jeklenih žičnih vrvi - Varnost - 6. del: Asimetrični zagozdni spoji

Terminations for steel wire ropes - Safety - Part 6: Asymmetric wedge socket

Endverbindungen für Drahtseile aus Stahldraht - Sicherheit - Teil 6: Asymmetrische Seilschlösser

Terminaisons pour câbles en acier - Sécurité - Partie 6: Boîte à coin asymétrique

STANDARD PREVIEW
(standards.iteh.ai)

Ta slovenski standard je istoveten z: EN 13411-6:2004+A1:2008

<https://standards.iteh.ai/catalog/standards/sist/a4996829-19ce-4e97-92c7-9c750e23c0e5/sist-en-13411-6-2004a1-2008>

ICS:

53.020.30	Pribor za dvigalno opremo	Accessories for lifting equipment
77.140.99	Drugi železni in jekleni izdelki	Other iron and steel products

SIST EN 13411-6:2004+A1:2008 **en,fr**

iTeh STANDARD PREVIEW
(standards.iteh.ai)

SIST EN 13411-6:2004+A1:2008

<https://standards.iteh.ai/catalog/standards/sist/a4996829-19ce-4e97-92c7-9c750e23c0e5/sist-en-13411-6-2004a1-2008>

EUROPEAN STANDARD
NORME EUROPÉENNE
EUROPÄISCHE NORM

EN 13411-6:2004+A1

October 2008

ICS 21.060.70; 53.020.30

Supersedes EN 13411-6:2004

English Version

Terminations for steel wire ropes - Safety - Part 6: Asymmetric wedge socket

Terminaisons pour câbles en acier - Sécurité - Partie 6:
Boîte à coin asymétrique

Endverbindungen für Drahtseile aus Stahldraht - Sicherheit
- Teil 6: Asymmetrische Seilschlösser

This European Standard was approved by CEN on 24 March 2004 and includes Amendment 1 approved by CEN on 18 September 2008.

CEN members are bound to comply with the CEN/CENELEC Internal Regulations which stipulate the conditions for giving this European Standard the status of a national standard without any alteration. Up-to-date lists and bibliographical references concerning such national standards may be obtained on application to the CEN Management Centre or to any CEN member.

This European Standard exists in three official versions (English, French, German). A version in any other language made by translation under the responsibility of a CEN member into its own language and notified to the CEN Management Centre has the same status as the official versions.

iTeh STANDARD PREVIEW

CEN members are the national standards bodies of Austria, Belgium, Bulgaria, Cyprus, Czech Republic, Denmark, Estonia, Finland, France, Germany, Greece, Hungary, Iceland, Ireland, Italy, Latvia, Lithuania, Luxembourg, Malta, Netherlands, Norway, Poland, Portugal, Romania, Slovakia, Slovenia, Spain, Sweden, Switzerland and United Kingdom.





[SIST EN 13411-6:2004+A1:2008](https://standards.iteh.ai/catalog/standards/sist/a4996829-19ce-4e97-92c7-9c750e23c0e5/sist-en-13411-6-2004a1-2008)

<https://standards.iteh.ai/catalog/standards/sist/a4996829-19ce-4e97-92c7-9c750e23c0e5/sist-en-13411-6-2004a1-2008>



EUROPEAN COMMITTEE FOR STANDARDIZATION
COMITÉ EUROPÉEN DE NORMALISATION
EUROPÄISCHES KOMITEE FÜR NORMUNG

Management Centre: rue de Stassart, 36 B-1050 Brussels

Contents	page
Foreword.....	3
Introduction	4
1 Scope	5
2 Normative references	5
3 Terms and definitions	5
4 List of significant hazards	6
5 Safety requirements and/or measures	7
6 Verification of safety requirements.....	9
7 Information for use	12
Annex A (informative) Asymmetric wedge socket with cast socket body – Design 1	14
Annex B (informative) Asymmetric wedge socket with cast socket body – Design 2	17
Annex C (informative) Recommendations for safe use and inspection	20
Annex ZA (informative)  Relationship between this European Standard and the Essential Requirements of EU Directive 98/37/EC 	23
Annex ZB (informative)  Relationship between this European Standard and the Essential Requirements of EU Directive 2006/42/EC 	24
Bibliography	25

<https://standards.iteh.ai/catalog/standards/sist/c4906829-19ce-4e07-92c7-9c750e23c0e5/sist-en-13411-6-2004a1-2008>

Foreword

This document (EN 13411-6:2004+A1:2008) has been prepared by Technical Committee CEN/TC 168 “Chains, ropes, webbing, slings and accessories - Safety”, the secretariat of which is held by BSI.

This European Standard shall be given the status of a national standard, either by publication of an identical text or by endorsement, at the latest by April 2009, and conflicting national standards shall be withdrawn at the latest by December 2009.

This document supersedes EN 13411-6:2004.

This document includes Amendment 1, approved by CEN on 2008-09-18.

The start and finish of text introduced or altered by amendment is indicated in the text by tags $\boxed{A_1}$ $\boxed{A_1}$.

This document has been prepared under a mandate given to CEN by the European Commission and the European Free Trade Association, and supports essential requirements of EU Directive(s).

$\boxed{A_1}$ For relationship with EU Directive(s), see informative Annexes ZA and ZB, which are integral parts of this document. $\boxed{A_1}$

Annexes A, B and C are informative.

This document includes a Bibliography.

EN 13411 with the general title *Terminations for steel wire ropes – Safety*, consists of the following parts:

Part 1: Thimbles for steel wire rope slings

Part 2: Splicing of eyes for wire rope slings

Part 3: Ferrules and ferrule-securing

Part 4: Metal and resin socketing

Part 5: U-bolt wire rope grips

Part 6: Asymmetric wedge socket

Part 7: Symmetric wedge socket

According to the CEN/CENELEC Internal Regulations, the national standards organizations of the following countries are bound to implement this European Standard: Austria, Belgium, Bulgaria, Cyprus, Czech Republic, Denmark, Estonia, Finland, France, Germany, Greece, Hungary, Iceland, Ireland, Italy, Latvia, Lithuania, Luxembourg, Malta, Netherlands, Norway, Poland, Portugal, Romania, Slovakia, Slovenia, Spain, Sweden, Switzerland and United Kingdom.

EN 13411-6:2004+A1:2008 (E)**Introduction**

This European Standard is a Type C Standard as stated in EN 1070.

This European Standard has been prepared to provide a means of conforming with the essential requirements of the Machinery Directive and associated EFTA regulations.

Purchasers ordering to this standard are advised to specify in their purchasing contract that the supplier operates an independently verified quality assurance system to ensure themselves that products claimed to comply consistently achieve the required level of quality.

The wedge sockets concerned and the extent to which hazards, hazardous situations and events are covered are indicated in the scope of this document.

When provisions of this Type C standard are different from those which are stated in Type A or B standards, the provisions of this Type C standard take precedence over the provisions of the other standards, for asymmetric wedge sockets that have been designed and produced according to the provisions of this Type C standard.

iTeh STANDARD PREVIEW
(standards.iteh.ai)

[SIST EN 13411-6:2004+A1:2008](https://standards.iteh.ai/catalog/standards/sist/a4996829-19ce-4e97-92c7-9c750e23c0e5/sist-en-13411-6-2004a1-2008)

<https://standards.iteh.ai/catalog/standards/sist/a4996829-19ce-4e97-92c7-9c750e23c0e5/sist-en-13411-6-2004a1-2008>

1 Scope

This European Standard specifies the minimum requirements, for asymmetrical wedge socket terminations for stranded steel wire ropes.

Examples of the construction and sizes of two separate designs of asymmetric wedge sockets are given in informative annexes A and B.

The informative annex C gives recommendations for safe use and inspection.

This European Standard deals with all significant hazards, hazardous situations and events relevant to asymmetric wedge sockets for terminations for steel wire ropes, when used as intended and under conditions of misuse which are reasonably foreseeable by the manufacturer.

This standard applies to terminations of steel wire ropes with asymmetrical wedge sockets which are manufactured after the date of its publication.

This standard does not cover rope fatigue.

2 Normative references

The following referenced documents are indispensable for the application of this document. For dated references, only the edition cited applies. For undated references, the latest edition of the referenced document (including any amendments) applies.

EN 1050:1996, *Safety of machinery – Principles for risk assessment*.

EN 1369: 1996, *Founding - Magnetic particle inspection*.

EN 1371-1:1997, *Founding – Liquid penetrant inspection – Part 1: Sand, gravity die and low pressure die castings*.

EN 10045-1, *Metallic materials - Charpy impact test – Part 1: Test method*.

EN 12385-2:2002, *Steel wire ropes - Safety - Part 2: Definitions, designation and classification*.

EN 45012, *General requirements for bodies operating assessment and certification/registration of quality systems ISO/IEC Guide 62:1996*.

EN ISO 7500-1, *Metallic materials - Verification of static uniaxial testing machines - Part 1: Tension/compression testing machines (ISO 7500-1:1999)*.

EN ISO 12100-2:2003, *Safety of machinery – Basic concepts, general principles for design – Part 2: Technical principles and specifications (ISO 12100-2:2003)*.

3 Terms and definitions

For the purposes of this European Standard, the terms and definitions given in EN 12385-2:2002 and the following apply.

3.1

asymmetric wedge socket

assembly consisting of a socket body, wedge, and pin; when assembled the centre line of the pin is directly in line with the longitudinal axis of the live portion of the rope

3.2

socket body

principal component of a wedge socket termination having an internal tapered form (see Figure 1) suitable for receiving a wedge (see 3.3) and the rope with which the wedge is associated

3.3

wedge

flat tapered component with peripheral groove, suitable for fitting into a tapered socket body to accommodate a rope of matching nominal diameter, see Figure 1

EN 13411-6:2004+A1:2008 (E)**3.4****pin**

removable component intended to facilitate connection of the socket body to its anchorage point

3.5**lot**

number of asymmetric wedge sockets from which samples are selected for testing purposes which are of the same type and dimension, each of their constituent components manufactured during the same production run from material of the same cast and subjected to the same heat treatment process

4 List of significant hazards

This standard contains all the significant hazards, hazardous situations and events, as far as they have been dealt with in this standard, identified by risk assessment as significant for this type of steel wire rope termination which require action to eliminate or reduce the risk.

In particular hazards caused by accidental release of a load, or release of a load due to failure of an asymmetric wedge socket puts at risk, either directly or indirectly, the safety or health of those persons within the hazard zone.

Errors in the fitting of accessories can also lead to premature failure and this standard contains dimensional requirements to allow correct fit.

Table 1 contains those hazards that require action to reduce risk identified by risk assessment as being specific and significant for asymmetric wedge sockets.

Table 1 — Hazards and associated requirements

Hazards identified in annex A of EN 1050:1996		Relevant clause of annex A of EN ISO 12100-2:2003	Relevant clause/ subclause of this Part of EN
1.1.5	Mechanical hazard due to inadequacy of strength	1.3.1	5
		4.1.2.3	5
		4.1.2.4	5
		4.2.4	7
		4.3.2	7
1.3	Cutting or severing hazard	1.3.4	7
15	Errors of fitting	4.3.2	7

5 Safety requirements and/or measures

5.1 Geometry of wedge and socket body

Asymmetric wedge socket terminations for ropes shall conform to the following geometrical criteria (see Figure 1):

The longitudinal axis of the live portion of the rope shall be perpendicular to the longitudinal axis of the pin.

The difference between the wedge angle (α) and the socket angle (β) shall be not greater than 2° .

The internal side surfaces of the socket body and the wedge in contact with the rope shall be straight.

The clamping length between socket body and the wedge in contact with the live portion of the rope shall be a minimum length (P) equal to 4,3 times the nominal rope diameter.

The rope groove in the socket body and the wedge shall not exhibit protrusions, marks or casting joints that would affect the intimate contact with the rope.

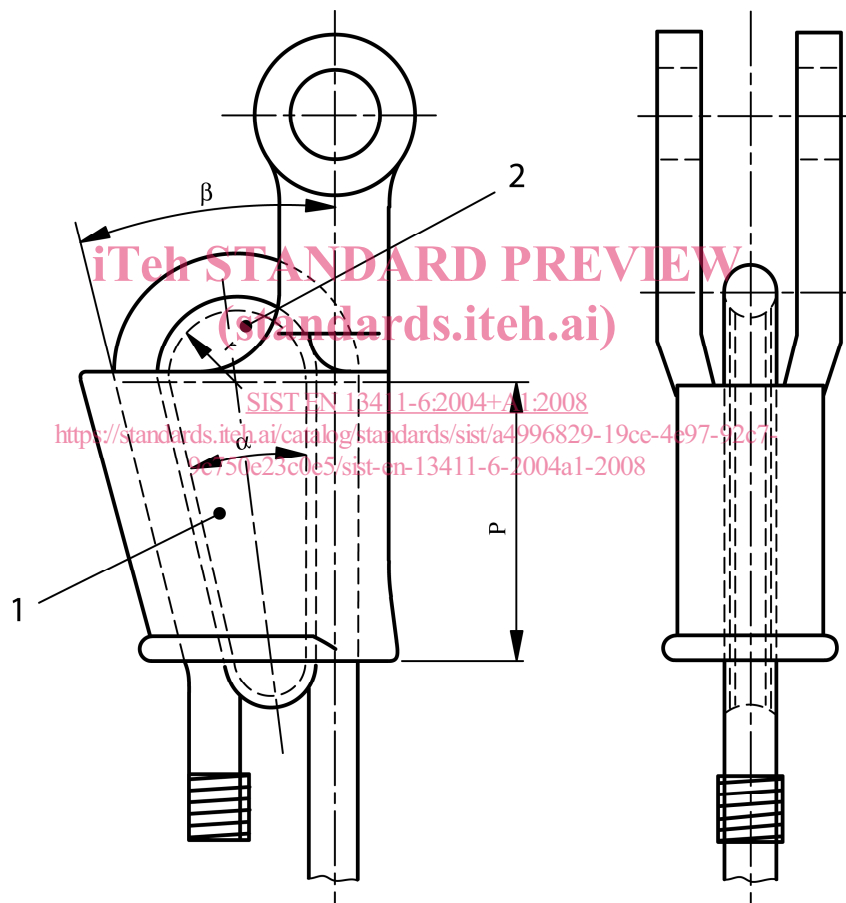

Key

- 1 Socket body
- 2 Wedge

Figure 1 – Functional dimensions (pin and securing means not shown)

EN 13411-6:2004+A1:2008 (E)**5.2 Security of the pin**

The pin shall be provided with a means for securing it in position when in operation.

5.3 Mechanical properties**5.3.1 Termination and wedge security**

When tested in accordance with 6.2.2 the assembled and loaded termination, after initial settlement, shall during the noted two minute period exhibit no further movement between the rope and the termination, monitored either as movement of the tail of the rope, or as relative movement between the rope and the wedge.

After release of the specified load when tested in accordance with 6.2.2 no relative movement shall occur between the wedge and socket body.

5.3.2 Manufacturing proof force and deformation test

When tested in accordance with 6.2.3 and 6.3.1, the socket body arms and pin shall show no sign of permanent deformation.

5.3.3 Fatigue behaviour of the socket body and pin

When tested in accordance with 6.2.4 the socket body and pin shall not exhibit any indications of cracks after 75000 load cycles.

The socket shall also exhibit no sign of local permanent deformation in the pin eye holes.

5.3.4 Termination efficiency

When tested in accordance with 6.2.5 the efficiency of the assembled termination shall be at least 80% of the minimum breaking force of the rope.

STANDARD PREVIEW
(standards.iteh.ai)
SIST EN 13411-6:2004+A1:2008
<https://standards.iteh.ai/catalog/standards/sist/a4996829-19ce-4e97-92c7-9c750e23c0e5/sist-en-13411-6-2004a1-2008>

5.3.5 Low temperature properties

The materials of the socket, body and pin when tested in accordance with 6.2.6 shall possess minimum low temperature ductility and toughness qualities at -20°C as follows:

- Steel socket body and/or pin:
Minimum average Charpy impact value of 27 J, with no individual value less than 18 J.
- Spheroidal graphite cast iron and any other cast irons: socket body:
Minimum average Charpy impact value of 12 J, with no individual value less than 9 J.

6 Verification of safety requirements

6.1 Qualifications of personnel

All testing and examination shall be carried out by a competent person.

6.2 Type testing

6.2.1 General

Two type tests shall be carried out for each requirement, in accordance with 6.2.2 to 6.2.5, on assembled terminations of each design, material and method of manufacture, using the highest minimum breaking force of rope for which the socket is designed.

If the four requirements tests are carried out using the same socket body, wedge and pin, they shall be conducted in the order of termination and wedge security, deformation, fatigue and tensile efficiency testing, renewing the rope as necessary.

The testing machine shall conform to the requirements of EN ISO 7500-1.

If the dimensional criteria or the chemical composition, or heat treatment of the socket body and pin are subsequently varied outside the usual manufacturing tolerances, the type tests shall be repeated.

6.2.2 Termination and wedge security test

Subject the assembled termination to a load of 20% of the minimum breaking force of the rope, sustain this load for an initial period to allow settlement of the termination, then continue to sustain for a further 2 min before removing the load.

6.2.3 Deformation test

SIST EN 13411-6:2004+A1:2008

<https://standards.iteh.ai/catalog/standards/sist/a4996829-19ce-4e97-92c7->

The termination shall be further loaded until this load reaches a value equal to 40% of the minimum breaking force of the rope. The load shall then be removed, the termination dismantled and the socket body and pin examined for permanent deformation.

6.2.4 Fatigue test

The test shall be carried out on an in-line tensile fatigue machine. The termination shall be prevented from rotating and the test shall consist of the application of the cycle force from 15% to 30% of the minimum breaking force of the rope along the rope axis for 75000 cycles.

The frequency of the force shall not exceed 5 Hz.

The component parts shall be submitted to either dye penetrant or magnetic particle inspection in accordance with EN 1369 or EN 1371-1 both before and after the fatigue test to enable any crack initiation and propagation as a result of fatigue to be readily identified.

NOTE More than one rope may be required to enable the socket body to achieve 75000 cycles.

6.2.5 Tensile efficiency test

Subject the assembled termination to an initial load of 60% of the minimum breaking force of the rope, then increasing this load at a rate of not more than 0,5% of the breaking force per second. The test shall be continued until either rope slip or breakage occurs.

If terminations are tested in pairs, the distance between the inner faces of the socket bodies shall be at least 30 d.