

---

---

**Carbonaceous materials used in the  
production of aluminium — Baked  
anodes — Determination of the reactivity  
to carbon dioxide —**

**Part 2:  
Thermogravimetric method**

iTeh STANDARD PREVIEW  
(standards.iteh.ai)

*Produits carbonés utilisés pour la production de l'aluminium — Anodes  
cuites — Détermination de la réactivité au dioxyde de carbone —*

*ISO 12988-2:2004  
Partie 2: Méthode thermogravimétrique*

<https://standards.iteh.ai/catalog/standards/sist/096d1bd2-07ff-4ca4-986c-267fbb30ab83/iso-12988-2-2004>



**PDF disclaimer**

This PDF file may contain embedded typefaces. In accordance with Adobe's licensing policy, this file may be printed or viewed but shall not be edited unless the typefaces which are embedded are licensed to and installed on the computer performing the editing. In downloading this file, parties accept therein the responsibility of not infringing Adobe's licensing policy. The ISO Central Secretariat accepts no liability in this area.

Adobe is a trademark of Adobe Systems Incorporated.

Details of the software products used to create this PDF file can be found in the General Info relative to the file; the PDF-creation parameters were optimized for printing. Every care has been taken to ensure that the file is suitable for use by ISO member bodies. In the unlikely event that a problem relating to it is found, please inform the Central Secretariat at the address given below.

**iTeh STANDARD PREVIEW**  
**(standards.iteh.ai)**

[ISO 12988-2:2004](#)

<https://standards.iteh.ai/catalog/standards/sist/096d1bd2-07ff-4ca4-986c-267fbb30ab83/iso-12988-2-2004>

© ISO 2004

All rights reserved. Unless otherwise specified, no part of this publication may be reproduced or utilized in any form or by any means, electronic or mechanical, including photocopying and microfilm, without permission in writing from either ISO at the address below or ISO's member body in the country of the requester.

ISO copyright office  
Case postale 56 • CH-1211 Geneva 20  
Tel. + 41 22 749 01 11  
Fax + 41 22 749 09 47  
E-mail [copyright@iso.org](mailto:copyright@iso.org)  
Web [www.iso.org](http://www.iso.org)

Published in Switzerland

**Contents**

Page

<b>Foreword</b> .....	<b>iv</b>
<b>Introduction</b> .....	<b>v</b>
<b>1 Scope</b> .....	<b>1</b>
<b>2 Normative references</b> .....	<b>1</b>
<b>3 Terms and definitions</b> .....	<b>1</b>
<b>4 Principle</b> .....	<b>2</b>
<b>5 Apparatus</b> .....	<b>2</b>
<b>6 Reagents</b> .....	<b>5</b>
<b>7 Sample</b> .....	<b>5</b>
<b>8 Calibration</b> .....	<b>5</b>
<b>9 Procedure</b> .....	<b>7</b>
<b>10 Calculation of results</b> .....	<b>7</b>
<b>11 Precision and bias</b> .....	<b>9</b>
<b>12 Test report</b> .....	<b>11</b>
<b>Bibliography</b> .....	<b>12</b>

[ISO 12988-2:2004](https://standards.iteh.ai/catalog/standards/sist/096d1bd2-07ff-4ca4-986c-267fbb30ab83/iso-12988-2-2004)  
<https://standards.iteh.ai/catalog/standards/sist/096d1bd2-07ff-4ca4-986c-267fbb30ab83/iso-12988-2-2004>

## Foreword

ISO (the International Organization for Standardization) is a worldwide federation of national standards bodies (ISO member bodies). The work of preparing International Standards is normally carried out through ISO technical committees. Each member body interested in a subject for which a technical committee has been established has the right to be represented on that committee. International organizations, governmental and non-governmental, in liaison with ISO, also take part in the work. ISO collaborates closely with the International Electrotechnical Commission (IEC) on all matters of electrotechnical standardization.

International Standards are drafted in accordance with the rules given in the ISO/IEC Directives, Part 2.

The main task of technical committees is to prepare International Standards. Draft International Standards adopted by the technical committees are circulated to the member bodies for voting. Publication as an International Standard requires approval by at least 75 % of the member bodies casting a vote.

Attention is drawn to the possibility that some of the elements of this document may be the subject of patent rights. ISO shall not be held responsible for identifying any or all such patent rights.

ISO 12988-2 was prepared by Technical Committee ISO/TC 47, *Chemistry*, Subcommittee SC 7, *Aluminium oxide, cryolite, aluminium fluoride, sodium fluoride, carbonaceous products for the aluminium industry*.

ISO 12988 consists of the following parts, under the general title *Carbonaceous materials used in the production of aluminium — Baked anodes — Determination of the reactivity to carbon dioxide*:

— Part 1: *Loss in mass method*

— Part 2: *Thermogravimetric method*

[ISO 12988-2:2004](https://standards.iteh.ai/catalog/standards/sist/096d1bd2-07ff-4ca4-986c-267fbb30ab83/iso-12988-2-2004)

<https://standards.iteh.ai/catalog/standards/sist/096d1bd2-07ff-4ca4-986c-267fbb30ab83/iso-12988-2-2004>

## Introduction

The CO<sub>2</sub> reactivities, or reaction rates, are used to quantify the tendency of a carbon artifact to react with carbon dioxide. Carbon consumed by these unwanted side reactions is unavailable for the primary reactions of reducing alumina to the primary metal. CO<sub>2</sub> reactivities and dusting rates are used to quantify the tendency of the coke aggregate or binder coke of a carbon artifact to selectively react with these gases. Preferential attack of the binder coke or coke aggregate of a carbon artifact by these gases causes some carbon to fall off or dust, making the carbon unavailable for the primary reaction of reducing alumina and, more importantly, reducing the efficiency of the aluminium reduction cell.

Comparison of CO<sub>2</sub> reactivities and dusting rates is useful in selecting raw materials for the manufacture of commercial anodes for specific smelting technologies in the aluminium reduction industry.

CO<sub>2</sub> reactivities are used for evaluating effectiveness and beneficiation processes, or for research purposes.

Sampling guidelines are under development.

This part of ISO 12988 is based on ASTM D 6558-00.

## iTeh STANDARD PREVIEW (standards.iteh.ai)

[ISO 12988-2:2004](https://standards.iteh.ai/catalog/standards/sist/096d1bd2-07ff-4ca4-986c-267fbb30ab83/iso-12988-2-2004)

<https://standards.iteh.ai/catalog/standards/sist/096d1bd2-07ff-4ca4-986c-267fbb30ab83/iso-12988-2-2004>

**iTeh STANDARD PREVIEW**  
**(standards.iteh.ai)**

ISO 12988-2:2004

<https://standards.iteh.ai/catalog/standards/sist/096d1bd2-07ff-4ca4-986c-267fbb30ab83/iso-12988-2-2004>

# Carbonaceous materials used in the production of aluminium — Baked anodes — Determination of the reactivity to carbon dioxide —

## Part 2: Thermogravimetric method

**WARNING** — This part of ISO 12988 does not purport to address all of the safety concerns, if any, associated with its use. It is the responsibility of the user of this part of ISO 12988 to establish appropriate safety and health practices and determine the applicability of regulatory limitations prior to use.

### 1 Scope

This test method covers the thermogravimetric (TGA) determination of CO<sub>2</sub> reactivities and dusting of shaped carbon anodes used in the aluminium reduction industry. Many types of apparatus are available with a wide variety of thermal conditions, sample-size capability, materials of construction and procedures for determining the mass loss and subsequent rate of reaction. This test method standardizes the variables of sample dimensions, reaction temperature, gas velocity over the exposed surfaces, and reaction time such that results obtained on different types of apparatus are correlatable.

<https://standards.iteh.ai/catalog/standards/sist/096d1bd2-07ff-4ca4-986c-267fbb30ab83/iso-12988-2-2004>

### 2 Normative references

The following referenced documents are indispensable for the application of this document. For dated references, only the edition cited applies. For undated references, the latest edition of the referenced document (including any amendments) applies.

ASTM E 691-99, *Standard Practice for Conducting an Interlaboratory Study to Determine the Precision of a Test Method*

### 3 Terms and definitions

For the purposes of this part of ISO 12988, the following terms and definitions apply.

#### 3.1 dusting

$a_{RCD}$   
that quantity of carbon that falls off the carbon artifact during the test and is collected in the container at the bottom of the reaction chamber

#### 3.2 final CO<sub>2</sub> reactivity

$a_{RCf}$   
rate of mass loss of the carbon artifact during the final 30 min of exposure to CO<sub>2</sub> in the reaction chamber divided by the initial geometric (right cylindrical) exposed surface area of the sample

NOTE The final CO<sub>2</sub> reactivity is expressed in milligrams per square centimetre per hour.

### 3.3

#### initial CO<sub>2</sub> reactivity

$a_{RCi}$

rate of mass loss of the carbon artifact during the first 30 min of exposure to CO<sub>2</sub> in the reaction chamber divided by the initial geometric (right cylindrical) exposed surface area of the sample

NOTE The initial CO<sub>2</sub> reactivity is expressed in milligrams per square centimetre per hour.

### 3.4

#### total CO<sub>2</sub> reactivity

$a_{RCt}$

rate of mass loss of the carbon artifact (including dusting) during the total time that the sample is exposed to CO<sub>2</sub> (420 min) in the reaction chamber divided by the initial geometric (right cylindrical) exposed surface area of the sample

NOTE The total CO<sub>2</sub> reactivity is expressed in milligrams per square centimetre per hour.

## 4 Principle

The dusting rate and the initial, final and total CO<sub>2</sub> reactivities are determined by passing carbon dioxide gas at a flow rate that gives a standard velocity of reactant gas around cylindrically shaped carbon artifacts under isothermal conditions for a specified length of time. The reactivity is determined by continuously monitoring the sample mass loss. The CO<sub>2</sub> dusting rate is determined by collecting and determining the mass of carbon particles that fall off the sample during reaction.

iTeh STANDARD PREVIEW  
(standards.iteh.ai)

## 5 Apparatus

The apparatus to be used should be as simple as possible and be commensurate with what is to be achieved. The principal criterion is that the reaction rate be determined under isothermal conditions and be unaffected by physical and chemical properties inherent to the apparatus<sup>2</sup> (such as gas diffusion patterns, gas temperature, exposed sample surface area, and so forth). A typical apparatus that has been found to be suitable is illustrated in Figure 1.

**5.1 Furnace and controller**, capable of maintaining constant temperature, within  $\pm 2$  °C in the 100-mm reaction zone in which the sample is centred.

A typical apparatus, as illustrated in Figure 1, employs a three-zone heating element and associated controls to accomplish this, but other types of heaters such as tapered windings or long linear heaters are also suitable. The control thermocouple is a grounded type and shall be located within the reaction chamber near the surface of the test sample. This is to allow the furnace controller to compensate for the exothermic reactions that occur when the furnace is used for air reactivity testing. The control thermocouple shall be positioned  $4 \text{ mm} \pm 1 \text{ mm}$  from the side surface of the sample and within 5 mm vertically of the centre of the reaction chamber. The furnace shall be large enough to accommodate the reaction chamber.

**5.2 Reaction chamber**, consisting of a vertical tube constructed of a material capable of withstanding the temperature of the reaction, e.g.  $960 \text{ °C} \pm 2 \text{ °C}$  with a sufficiently large inside diameter to accommodate the sample and sample suspension device while not affecting the gas flow past the sample. An inside diameter of  $100 \text{ mm} \pm 25 \text{ mm}$  is recommended.

The reaction chamber shall be constructed with a removable dust-collection cup at the bottom capable of capturing all the dust that falls off the sample during the test. The most common materials of construction are quartz and Inconel<sup>1</sup>).

---

1) Inconel is an example of a suitable product available commercially. This information is given for the convenience of users of this part of ISO 12988 and does not constitute an endorsement by ISO of this product.



**5.3 Sample suspension device**, capable of supporting the sample in the reaction chamber for the duration of the test and which should be reusable.

The sample holder shall not change in mass during the test, shall not affect the flow pattern of the gas past the sample, shall not limit the gas-accessible surface area of the test sample and shall not interfere with the production of dust by the sample. A typical sample holder is illustrated in Figure 2.

Dimensions in millimetres

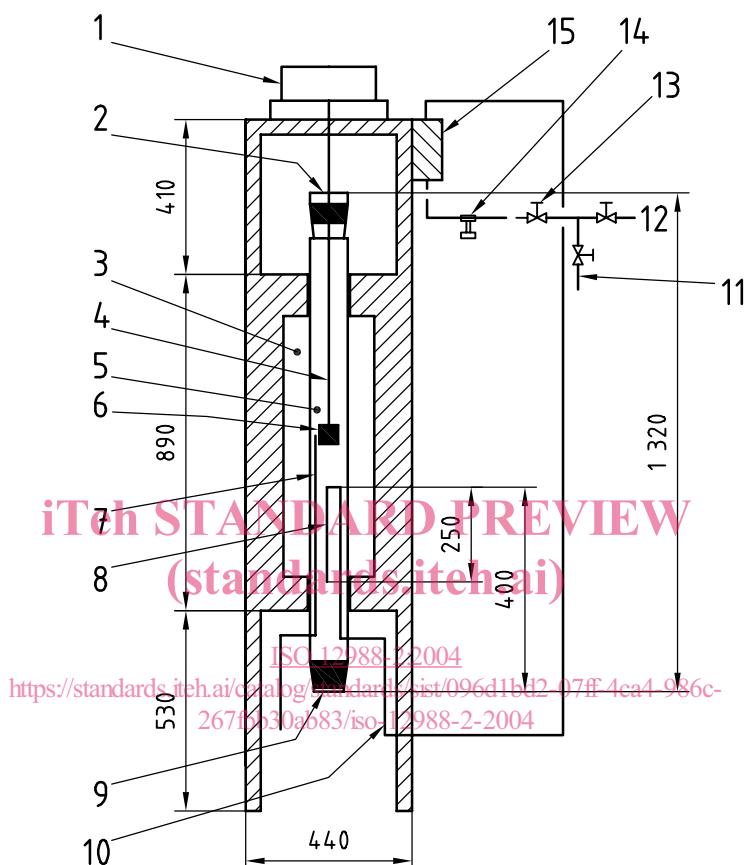

**Key**

- |   |                                |    |                         |
|---|--------------------------------|----|-------------------------|
| 1 | balance                        | 9  | dust-collection cup     |
| 2 | gas outlet (10 mm hole)        | 10 | gas inlet               |
| 3 | three-zone furnace             | 11 | air or CO <sub>2</sub>  |
| 4 | connecting wire (see Figure 2) | 12 | N <sub>2</sub>          |
| 5 | reaction chamber               | 13 | pressure-reducing valve |
| 6 | sample                         | 14 | needle valve            |
| 7 | control thermocouple           | 15 | flow meter              |
| 8 | preheat tube                   |    |                         |

**Figure 1 — Typical CO<sub>2</sub> reactivity apparatus**

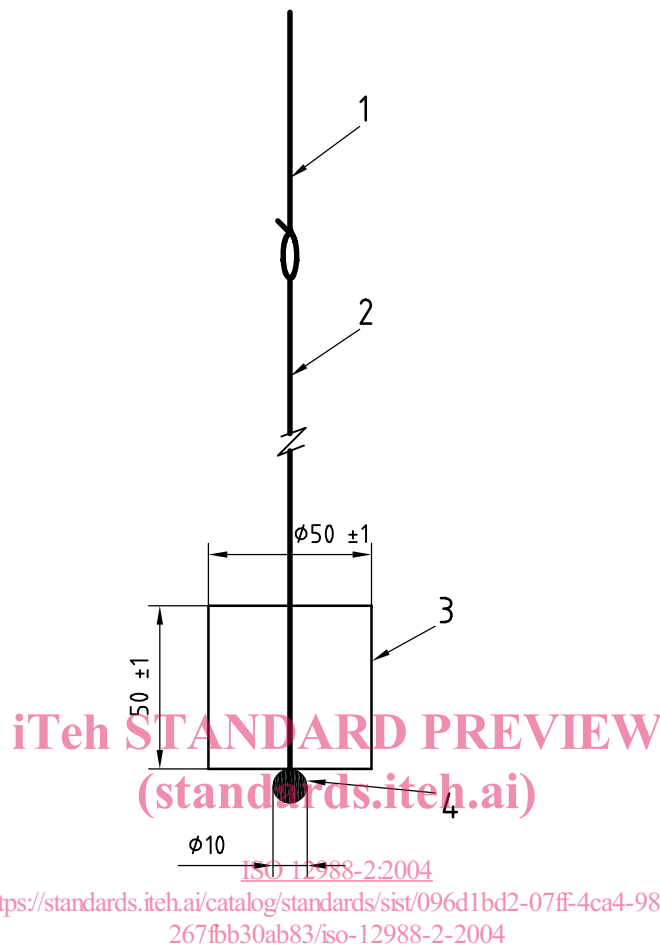

**Key**

- |   |   |   |                      |
|---|---|---|----------------------|
| 1 | suspension wire (Nichrome <sup>2)</sup> )     | 3 | cylindrical sample   |
| 2 | sample support wire (platinum, 1 mm diameter) | 4 | stainless steel ball |

**Figure 2 — Typical sample suspension arrangement**

**5.4 Gas preheat tube**, extending into the first heating zone of the reaction chamber, to preheat the gas prior to entering the reaction chamber.

The length and diameter of the tube may vary, as long as the gas leaving the tube is at the same temperature as the reaction chamber. The inlet gas shall leave the preheat tube downward to prevent channelling of the gas through the reaction chamber and to prevent plugging of the preheat tube with carbon dust.

**5.5 Balance**, capable of measuring the mass (approximately 200 g maximum) of the sample and sample suspension device to the nearest 0,01 g continuously throughout the duration of the test.

**5.6 Gas flow meter**, capable of measuring the flow rate of the gas entering the reaction chamber.

All gas flow rates shall be maintained at the rate determined for the particular test apparatus.

**5.7 Needle valve**, to make fine adjustments to the gas flow rate.

---

2) Nichrome is an example of a suitable product available commercially. This information is given for the convenience of users of this part of ISO 12988 and does not constitute an endorsement by ISO of this product.

**5.8 Pressure-reducing valve**, to reduce the pressure of the compressed gas to near atmospheric pressure before it enters the gas flow meter through the needle valve.

**5.9 Thermocouple(s)**, inserted into the reaction chamber to calibrate the furnace zone controllers.

An optional thermocouple may be used to monitor reaction temperatures. Some users find continuous temperature measurement of the central part of the reaction chamber to be of value.

**5.10 Callipers**, or other suitable device, capable of measuring to within 0,01 mm for determining the sample diameter and height to calculate geometric surface area exposed to the test gas.

**5.11 Optional equipment**, including, but not limited to, automatic control devices, multi-channel line selectors and personal computers to automate data recording, processing, reporting and storage.

## 6 Reagents

Use only reagents of recognized analytical grade, unless otherwise specified.

**6.1 Nitrogen**, 99,95 %.

**6.2 Carbon dioxide**, 99,95 %.

## 7 Sample

**7.1** Prepare the carbon sample by coring and cutting or machining to a right cylinder, 50 mm  $\pm$  1,0 mm long and 50 mm  $\pm$  1,0 mm in diameter. Most sample suspension devices (5.3) require a hole of about 3 mm in diameter to be drilled vertically through the centre of the cylinder to accommodate a suspension wire. The finished specimen shall be smooth and free of visible cracks and gouges.

Sampling plans for anodes and cathode blocks given in ASTM D 6353 and D 6354 may be used if desired.

**7.2** Dry the finished specimen in an oven at 105 °C  $\pm$  5 °C to constant mass.

**7.3** Free the finished sample from loose carbon dust and impurities from the shaping process by blowing with dry air.

## 8 Calibration

**8.1** The purpose of this procedure is to establish a relationship between the controller settings for three-zone furnace and the actual temperature inside the reaction chamber in the region of the sample. The length of the calibrated zone shall be 100 mm.

For single-zone furnaces, place the calibration probe in the zone where the sample will be located and verify that the 100-mm zone centred on the sample location has a temperature of 960 °C  $\pm$  2 °C.

**8.2** Insert a multi-probe thermocouple (5.9) into the zone where the sample will be located. Align the middle probe of the multi-probe thermocouple centre probe with the sample position.

**8.3** Connect the middle thermocouple (5.9) to the main controller. Set at 960 °C for CO<sub>2</sub> reactivity.

**8.4** Connect the other two thermocouples to any type of temperature-indicating device. A recording temperature indicator is required to determine the actual temperature profile.

**8.5** Allow 4 h for the furnace to reach equilibrium under a nitrogen purge (at a gas flow rate calculated in accordance with 8.7).