



Designation: E 426 – 98 (Reapproved 2003)^{e1}

Standard Practice for Electromagnetic (Eddy-Current) Examination of Seamless and Welded Tubular Products, Austenitic Stainless Steel and Similar Alloys¹

This standard is issued under the fixed designation E 426; the number immediately following the designation indicates the year of original adoption or, in the case of revision, the year of last revision. A number in parentheses indicates the year of last reapproval. A superscript epsilon (ϵ) indicates an editorial change since the last revision or reapproval.

This specification has been approved for use by agencies of the Department of Defense.

^{e1} NOTE—Editorial changes made throughout the standard in July 2003.

1. Scope

1.1 This practice² covers procedures that may be followed for eddy-current examination of seamless and welded tubular products made of stainless steel and similar alloys such as nickel alloys. Austenitic chromium-nickel stainless steels, which are generally considered to be nonmagnetic, are specifically covered as distinguished from the martensitic and ferritic straight chromium stainless steels which are magnetic.

1.2 This practice is intended as a guide for eddy-current examination of both seamless and welded tubular products using either an encircling coil or a probe-coil technique. Coils and probes are available that can be used inside the tubular product; however, their use is not specifically covered in this document. This type of examination is usually employed only to examine tubing which has been installed such as in a heat exchanger.

1.3 This practice covers the examination of tubular products ranging in diameter from 0.125 to 5 in. (3.2 to 127.0 mm) and wall thicknesses from 0.005 to 0.250 in. (0.127 to 6.4 mm).

1.4 The values stated in inch-pound units are to be regarded as the standard.

1.5 *This standard does not purport to address all of the safety problems, if any, associated with its use. It is the responsibility of the user of this standard to establish appropriate safety and health practices and determine the applicability of regulatory limitations prior to use.*

2. Referenced Documents

2.1 ASTM Standards:

¹ This practice is under the jurisdiction of ASTM Committee E07 on Nondestructive Testing and is the direct responsibility of Subcommittee E07.07 on Electromagnetic Methods.

Current edition approved July 10, 2003. Published September 2003. Originally approved in 1971. Last previous edition approved in 1998 as E 426 - 98.

² For ASME Boiler and Pressure Vessel Code applications see related Practice SE-426 in Section II of that Code.

E 543 Practice for Agencies Performing Nondestructive Testing³

E 1316 Terminology for Nondestructive Examinations³

2.2 Other Documents:

SNT-TC-1A Recommended Practice for Personnel Qualification and Certification in Nondestructive Testing⁴

ANSI/ASNT CP-189 ASNT Standard for Qualification and Certification of Nondestructive Testing Personnel⁴

NAS-410 NAS Certification and Qualification of Nondestructive Personnel (Quality Assurance Committee)⁵

3. Terminology

3.1 Standard terminology relating to electromagnetic examination may be found in Terminology E 1316, Section C, Electromagnetic Testing.

4. Summary of Practice

4.1 The examination is conducted using one of two general techniques shown in Fig. 1. One of these techniques employs one or more exciter and sensor coils which encircle the pipe or tube and through which the tubular product to be examined is passed. Some circuit configurations employ separate exciter and sensor coils; whereas other configurations employ one or more coils that concurrently function as both exciters and sensors. Alternating current passes through the exciting coil which by reason of its proximity induces current in the tubular product. The sensor coil detects the resultant electromagnetic flux related to these currents. The presence of discontinuities in the tubular product will affect the normal flow of currents and this change is detected by the sensor. The encircling coil

³ *Annual Book of ASTM Standards*, Vol 03.03.

⁴ Available from The American Society for Nondestructive Testing (ASNT), P.O. Box 28518, 1711 Arlinggate Lane, Columbus, OH 43228-0518.

⁵ Available from Aerospace Industries Association of America, Inc., 1250 Eye Street, N.W., Washington, DC 20005.

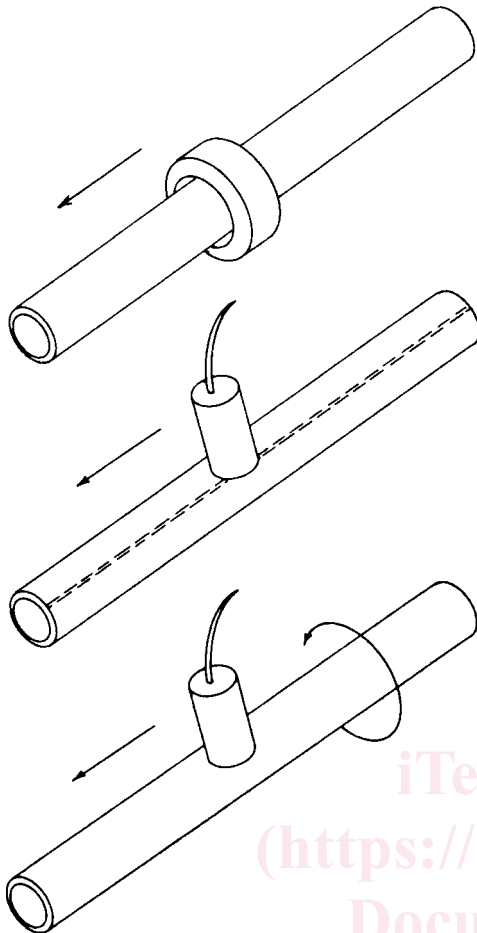

FIG. 1 Sketch Showing Encircling-Coil and Probe-Coil Techniques for Electromagnetic Examination of Tubular Products

technique is capable of examining the entire 360-deg expanse of the tubular product.

4.2 Another technique employs a probe coil with one or more exciters and sensors which is brought in close proximity of the surface of the tubular product to be examined. Since the probe is generally small and does not encircle the article being examined, it examines only a limited area in the vicinity of the probe. If it is desired to examine the entire volume of the tubular product, it is common practice to either rotate the tubular product or the probe. In the case of welded tubular products frequently only the weld is examined by scanning along the weld zone.

5. Significance and Use

5.1 Eddy-current examination is a nondestructive method of locating discontinuities in a product. Changes in electromagnetic response caused by the presence of discontinuities are detected by the sensor, amplified and modified in order to actuate audio or visual indicating devices, or both, or a mechanical marker. Signals can be caused by outer surface, inner surface, or subsurface discontinuities. The eddy-current examination is sensitive to many factors that occur as a result of processing (such as variations in conductivity, chemical composition, permeability, and geometry) as well as other

factors not related to the tubing. Thus, all received indications are not necessarily indicative of defective tubing.

6. Basis of Application

6.1 If specified in the contractual agreement, personnel performing examinations to this practice shall be qualified in accordance with a nationally recognized NDT personnel qualification practice or standard such as ANSI/ASNT-CP-189, SNT-TC-1A, NAS-410, ASNT-ACCP, or a similar document and certified by the certifying agency, as applicable. The practice or standard used and its applicable revision shall be identified in the contractual agreement between the using parties.

NOTE 1—MIL-STD-410 is canceled and has been replaced with NAS-410, however, it may be used with agreement between contracting parties.

6.2 If specified in the contractual agreement, NDT agencies shall be qualified and evaluated in accordance with Practice E 543. The applicable edition of Practice E 543 shall be specified in the contractual agreement.

7. Apparatus

7.1 *Electronic Apparatus*—The electronic apparatus shall be capable of energizing the examination coils or probes with alternating currents of suitable frequencies and shall be capable of sensing the changes in the electromagnetic response of the sensors. Equipment may include a detector, phase discriminator, filter circuits, modulation circuits, magnetic-saturation devices, recorders, and signaling devices as required for the particular application.

7.2 *Examination Coils*—Examination coils shall be capable of inducing current in the tube and sensing changes in the electrical characteristics of the tube.

NOTE 2—Fill factor effect is an important consideration since coupling variations can affect the examination significantly.

7.3 *Probe Coils*—Probe coils shall be capable of inducing current in the tube and sensing changes in the electrical characteristics of the tube (Note 3). Probes generally consist of an exciting coil and sensing coil or Hall element mounted in a common holder. A Hall element is a semiconductor that by reason of the Hall effect is capable of responding in a manner directly proportional to magnetic-flux density. However, when used with an exciting coil, it should be remembered that eddy-current flow is influenced by the excitation frequency.

NOTE 3—Lift-off effect is an important consideration since coupling variations can affect the examination significantly.

7.4 *Driving Mechanism*—A mechanical device capable of passing the tube through the examination coil or past the probe. It shall operate at a uniform speed with minimum vibration of coil, probe, or tube and maintain the article being examined in proper register or concentricity with the probe or examination coil. Where required, the mechanism shall be capable of uniformly rotating the tube or probe.

7.5 *Reference Standard*—The standard used to adjust the sensitivity setting of the apparatus shall be sound and of the same nominal alloy, temper, and nominal dimensions as the lot of tubes or pipes to be examined on a production basis. It shall be of sufficient length to permit the required spacing of the