



Designation: E 1561 – 93 (Reapproved 2003)

## Standard Practice for Analysis of Strain Gage Rosette Data<sup>1</sup>

This standard is issued under the fixed designation E 1561; the number immediately following the designation indicates the year of original adoption or, in the case of revision, the year of last revision. A number in parentheses indicates the year of last reapproval. A superscript epsilon ( $\epsilon$ ) indicates an editorial change since the last revision or reapproval.

### INTRODUCTION

There can be considerable confusion in interpreting and reporting the results of calculations involving strain gage rosettes, particularly when data are exchanged between different laboratories. Thus, it is necessary that users adopt a common convention for identifying the positions of the gages and for analyzing the data.

#### 1. Scope

1.1 The two primary uses of three-element strain gage rosettes are (a) to determine the directions and magnitudes of the principal surface strains and (b) to determine residual stresses. Residual stresses are treated in a separate ASTM standard, Test Method E 837. This practice defines a reference axis for each of the two principal types of rosette configurations used and presents equations for data analysis. This is important for consistency in reporting results and for avoiding ambiguity in data analysis—especially when computers are used. There are several possible sets of equations, but the set presented here is perhaps the most common.

#### 2. Referenced Documents

##### 2.1 ASTM Standards:

E 6 Terminology Relating to Methods of Mechanical Testing<sup>2</sup>

E 837 Test Method for Determining Residual Stresses by the Hole-Drilling Strain-Gage Method<sup>2</sup>

#### 3. Terminology

3.1 The terms in Terminology E 6 apply.

3.2 Additional terms and notation are as follows:

3.2.1 *reference line*—the axis of the *a* gage.

3.2.2 *a, b, c*—the three-strain gages making up the rosette.

For the 0° – 45° – 90° rosette (Fig. 1) the axis of the *b* gage is located 45° counterclockwise from the *a* (reference line) axis and the *c* gage is located 90° counterclockwise from the *a* axis. For the 0° – 60° – 120° rosette (Fig. 2) the axis of the *b* gage is located 60° counterclockwise from the *a* axis and the *c* axis is located 120° counterclockwise from the *a* axis.

<sup>1</sup> This practice is under the jurisdiction of ASTM Committee E28 on Mechanical Testing and is the direct responsibility of Subcommittee E28.01 on Calibration of Mechanical Testing Machines and Apparatus.

Current edition approved Nov. 15, 2005. Published January 2004. Originally approved in 1993. Last previous edition approved in 1998 as E1561–93(1998).

<sup>2</sup> Annual Book of ASTM Standards, Vol 03.01.

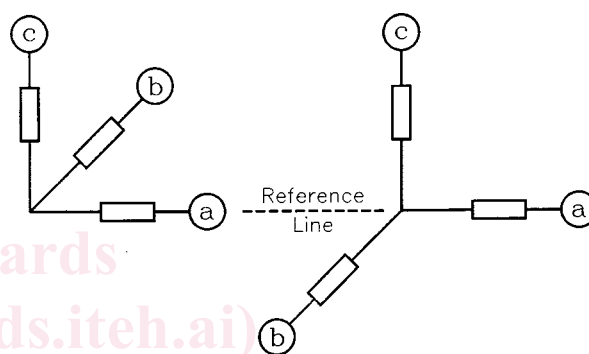

FIG. 1 0° – 45° – 90° Rosette

3.2.3  $\epsilon_a, \epsilon_b, \epsilon_c$ —the strains measured by gages *a, b,* and *c,* respectively, positive in tension and negative in compression. After corrections for thermal effects and transverse sensitivity have been made, the measured strains represent the surface strains at the site of the rosette. It is assumed here that the elastic modulus and thickness of the test specimen are such that mechanical reinforcement by the rosette are negligible. For test objects subjected to unknown combinations of bending and direct (membrane) stresses, the separate bending and membrane stresses can be obtained as shown in 4.4.

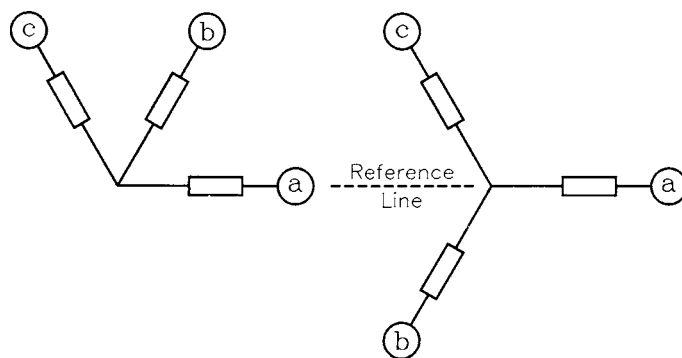

FIG. 2 0° – 60° – 120° Rosette

3.2.4  $\epsilon'_{a'}$ ,  $\epsilon'_{b'}$ ,  $\epsilon'_{c'}$ —reduced membrane strain components (4.4).

3.2.5  $\epsilon''_{a'}$ ,  $\epsilon''_{b'}$ ,  $\epsilon''_{c'}$ —reduced bending strain components (4.4).

3.2.6  $\epsilon_I$ —the calculated maximum (more tensile or less compressive) principal strain.

3.2.7  $\epsilon_2$ —the calculated minimum (less tensile or more compressive) principal strain.

3.2.8  $\gamma_M$ —the calculated maximum shear strain.

3.2.9  $\theta_I$ —the angle from the reference line to the direction of  $\epsilon_I$ . This angle is less than or equal to  $180^\circ$  in magnitude.

3.2.10  $C$ ,  $R$ —values used in the calculations.  $C$  is the location, along the  $\epsilon$ -axis, of the center of the Mohr's circle for strain and  $R$  is the radius of that circle.

4. Procedure

4.1 Fig. 3 shows a typical Mohr's circle of strain for a  $0^\circ - 45^\circ - 90^\circ$  rosette. The calculations when  $\epsilon_{a'}$ ,  $\epsilon_{b'}$ ,  $\epsilon_{c'}$ , are given are:

$$C = \frac{\epsilon_a + \epsilon_c}{2} \tag{1}$$

$$R = \sqrt{(\epsilon_a - C)^2 + (\epsilon_b - C)^2} \tag{2}$$

$$\epsilon_1 = C + R \tag{3}$$

$$\epsilon_2 = C - R \tag{3}$$

$$\gamma_M = 2R \tag{4}$$

$$\tan 2\theta_1 = 2(\epsilon_b - C) / \epsilon_a - \epsilon_c \tag{4}$$

4.1.1 If  $\epsilon_b < C$ , then the  $\epsilon_I$ -axis is clockwise from the reference line.

4.1.2 If  $\epsilon_b > C$ , then the  $\epsilon_I$ -axis is counterclockwise from the reference line.

4.2 Fig. 7 shows a typical Mohr's circle of strain for a  $0^\circ - 60^\circ - 120^\circ$  rosette. The calculations when  $\epsilon_{a'}$ ,  $\epsilon_{b'}$ ,  $\epsilon_{c'}$ , are given are:

$$C = \frac{\epsilon_a + \epsilon_b + \epsilon_c}{3} \tag{5}$$

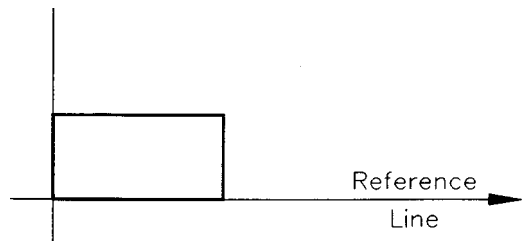

FIG. 4 Differential Element on the Undeformed Surface

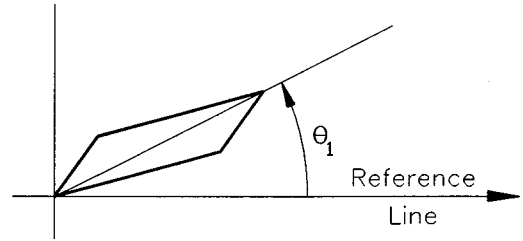

FIG. 5 Deformed Shape of Differential Element

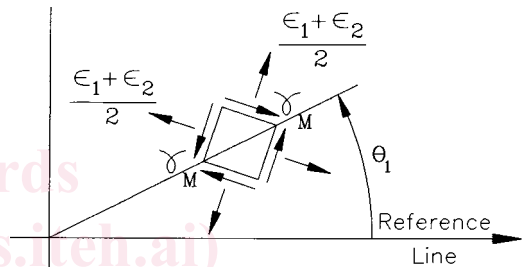

FIG. 6 Planes of Maximum Shear Strain

$$R = \sqrt{2/3[(\epsilon_a - C)^2 + (\epsilon_b - C)^2 + (\epsilon_c - C)^2]} \tag{6}$$

$$\epsilon_1 = C + R \tag{7}$$

$$\epsilon_2 = C - R \tag{7}$$

$$\gamma_M = 2R \tag{7}$$

$$\tan 2\theta_1 = \frac{(\epsilon_b - \epsilon_c)}{\sqrt{3}(\epsilon_a - C)} \tag{8}$$

4.2.1 If  $\epsilon_c - \epsilon_b < 0$ , then the  $\epsilon_I$ -axis is counterclockwise from the reference line.

4.2.2 If  $\epsilon_c - \epsilon_b = 0$ , then  $\theta_1 = 0^\circ$ .

4.2.3 If  $\epsilon_c - \epsilon_b > 0$ , then the  $\epsilon_I$ -axis is clockwise from the reference line (see Note 1).

4.3 Identification of the Maximum Principal Strain Direction:

4.3.1 Care must be taken when determining the angle  $\theta_1$  using (Eq 4) or (Eq 8) so that the calculated angle refers to the direction of the maximum principal strain  $\epsilon_1$  rather than the minimum principal strain  $\epsilon_2$ . Fig. 10 shows how the double angle  $2\theta_1$  can be placed in its correct orientation relative to the reference line shown in Fig. 1 and Fig. 2. The terms "numerator" and "denominator" refer to the numerator and denominator of the right-hand sides of (Eq 4) and (Eq 8). When both numerator and denominator are positive, as shown in Fig. 10, the double angle  $2\theta_1$  lies within the range  $0^\circ \leq 2\theta_1 \leq 90^\circ$  counterclockwise of the reference line. Therefore, in this particular case, the corresponding angle  $\theta_1$  lies within the range  $0^\circ \leq \theta_1 \leq 45^\circ$  counterclockwise of the reference line.

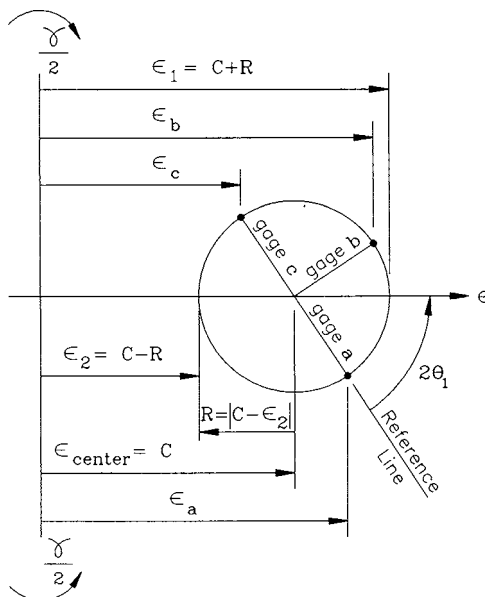

FIG. 3 Typical Mohr's Circle of Strain for a  $0^\circ - 45^\circ - 90^\circ$  Rosette