**Imaging materials — Photographic film and
paper — Determination of curl**

*Matériaux pour l'image — Films et papiers photographiques —
Détermination de l'incurvation*

iTeh STANDARD PREVIEW
(standards.iteh.ai)

[ISO 18910:2000](https://standards.iteh.ai/catalog/standards/sist/b00cb0b8-377d-4ec6-aaa4-277ea1ebff70/iso-18910-2000)

[https://standards.iteh.ai/catalog/standards/sist/b00cb0b8-377d-4ec6-aaa4-
277ea1ebff70/iso-18910-2000](https://standards.iteh.ai/catalog/standards/sist/b00cb0b8-377d-4ec6-aaa4-277ea1ebff70/iso-18910-2000)



PDF disclaimer

This PDF file may contain embedded typefaces. In accordance with Adobe's licensing policy, this file may be printed or viewed but shall not be edited unless the typefaces which are embedded are licensed to and installed on the computer performing the editing. In downloading this file, parties accept therein the responsibility of not infringing Adobe's licensing policy. The ISO Central Secretariat accepts no liability in this area.

Adobe is a trademark of Adobe Systems Incorporated.

Details of the software products used to create this PDF file can be found in the General Info relative to the file; the PDF-creation parameters were optimized for printing. Every care has been taken to ensure that the file is suitable for use by ISO member bodies. In the unlikely event that a problem relating to it is found, please inform the Central Secretariat at the address given below.

iTeh STANDARD PREVIEW
(standards.iteh.ai)

ISO 18910:2000

<https://standards.iteh.ai/catalog/standards/sist/b00cb0b8-377d-4ec6-aaa4-277ea1ebff70/iso-18910-2000>

© ISO 2000

All rights reserved. Unless otherwise specified, no part of this publication may be reproduced or utilized in any form or by any means, electronic or mechanical, including photocopying and microfilm, without permission in writing from either ISO at the address below or ISO's member body in the country of the requester.

ISO copyright office
Case postale 56 • CH-1211 Geneva 20
Tel. + 41 22 749 01 11
Fax + 41 22 734 10 79
E-mail copyright@iso.ch
Web www.iso.ch

Printed in Switzerland

Contents

	Page
Foreword.....	iv
1 Scope	1
2 Terms and definitions	1
3 Sampling and conditioning	3
4 Test method A	3
5 Test method B	4
6 Test method C	7
7 Test report	7
Annex A (informative) Numbering system for related International Standards	9
Bibliography	11

iTeh STANDARD PREVIEW (standards.iteh.ai)

ISO 18910:2000

<https://standards.iteh.ai/catalog/standards/sist/b00cb0b8-377d-4ec6-aaa4-277ea1ebff70/iso-18910-2000>

Foreword

ISO (the International Organization for Standardization) is a worldwide federation of national standards bodies (ISO member bodies). The work of preparing International Standards is normally carried out through ISO technical committees. Each member body interested in a subject for which a technical committee has been established has the right to be represented on that committee. International organizations, governmental and non-governmental, in liaison with ISO, also take part in the work. ISO collaborates closely with the International Electrotechnical Commission (IEC) on all matters of electrotechnical standardization.

International Standards are drafted in accordance with the rules given in the ISO/IEC Directives, Part 3.

Draft International Standards adopted by the technical committees are circulated to the member bodies for voting. Publication as an International Standard requires approval by at least 75 % of the member bodies casting a vote.

Attention is drawn to the possibility that some of the elements of this International Standard may be the subject of patent rights. ISO shall not be held responsible for identifying any or all such patent rights.

International Standard ISO 18910 was prepared by Technical Committee ISO/TC 42, *Photography*.

This first edition cancels and replaces the third edition of ISO 4330:1994, of which it constitutes a minor revision.

Annex A of this International Standard is for information only.

iTeh STANDARD PREVIEW
(standards.iteh.ai)
<https://standards.iteh.ai/catalog/standards/sist/b00cb0b8-377d-4ec6-aaa4-277ea1ebff70/iso-18910-2000>

Imaging materials — Photographic film and paper — Determination of curl

1 Scope

This International Standard specifies methods for determining and quantitatively expressing the curl characteristics of unprocessed and processed photographic film and paper in sheet, roll or strip formats.

It specifies three measuring methods: method A involves the determination of curl when the specimen is held in a vertical position, methods B and C with the specimen in a horizontal position. The values for the three methods are not comparable because of the differences in specimen configuration and size.

These methods are not intended for use in determining the curl characteristics of photographic materials during processing or drying.

2 Terms and definitions

For the purposes of this International Standard, the following terms and definitions apply.

2.1

curl

departure from physical flatness and characterized with respect to curl direction (L, T, D or C), curl sign (+ or –) and curl value

This flatness defect is evident by a tendency of film or paper to coil into a cylindrical shape.

2.2

curl direction

means of identifying by letter L, T, D or C the direction of curl about a specific axis of a specimen corresponding to that of the sample from which it is taken

See Figure 1.

NOTE

- | | |
|---|---|
| L | represents "lengthwise curl" about the axis perpendicular to the length or machine direction of the specimen for rolls or to the longer specimen dimension for sheets; an alternative approach when the machine direction is not known is to reference the curl direction to a film notch, if present |
| T | represents "transverse curl" about the axis parallel to the length or machine direction of the specimen |
| D | represents "diagonal curl" about the diagonal of the specimen |
| C | represents "cupping" when all four corners of the specimen are raised and bent towards the centre of the specimen |

2.3

curl sign

mathematical sign, + or –, used to indicate the direction of curl which, if toward the emulsion (sensitized) side (emulsion-in) is plus (+), or if toward the base (emulsion-out) is minus (–)

NOTE The sign is always plus for materials sensitized on both surfaces.

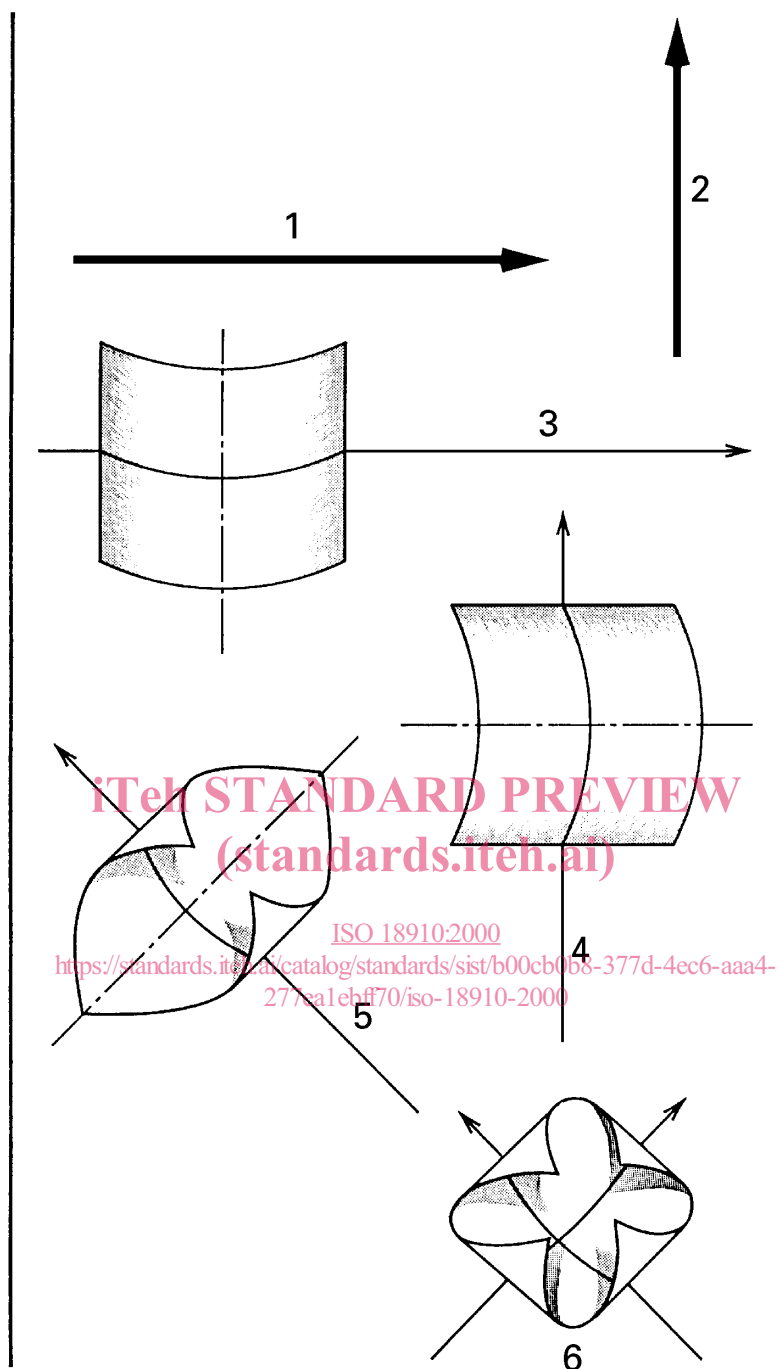

Key

- 1 Cross-machine direction or widthwise direction
- 2 Machine direction or lengthwise direction
- 3 Transverse curl (T curl)
- 4 Longitudinal curl (L curl)
- 5 Diagonal curl (D curl)
- 6 Cupping curl (C curl)

Figure 1 — Curl direction

3 Sampling and conditioning

3.1 Selection of samples

Material intended for curl tests shall be representative of the whole of the samples being tested, exhibit no obvious physical defects, be handled in the same manner as in actual use, and be treated uniformly.

When different materials are to be compared, they shall have been subjected to the same relative-humidity history for similar times.

The machine direction shall be indicated, if known, by crayon or ink marking.

3.2 Handling of specimens

Prepare specimens under controlled relative-humidity conditions, and then separate them into groups which are to be subjected to different atmospheric conditions.

Wear cotton or other suitable gloves or use pincers while handling specimens. Moisture from hands or fingers will reduce the accuracy of test data. The operator shall take care not to breath on the specimens.

3.3 Conditioning of specimens

Condition specimens at the chosen relative humidity until practical moisture equilibrium has been reached. In most instances, this time will be about 2 h for photographic films, 1 d for photographic fibrebase papers and 7 d for RC (resin coated) papers. At relative humidities of 70 % and above, films and papers sometimes undergo an irreversible change in curl with time. For this reason, the conditioning time must be standardized for comparison purposes.

Excessive conditioning times may result in a curl decrease due to relaxation effects.

Suspend the specimens freely by means of a hook or a rod through a hole close to the centre of one edge, and separate enough to prevent contact with each other. Hang square specimens with the axis of curl vertical to avoid producing distortion. An alternative method of support is to place specimens horizontally on net-covered or screen-covered racks spaced so that there is free circulation of air.

3.4 Test conditions

A temperature of $23\text{ °C} \pm 2\text{ °C}$ is specified. Relative humidities of 15 %, 30 %, 50 %, 70 % and 85 % are suggested but are not mandatory. Tests can be conducted in glove boxes or in conditioned rooms; the latter are preferable since they can provide better humidity control.

The curl value may be influenced by the moisture history of the material. This may be standardized by an initial preconditioning step at 50 % relative humidity.

4 Test method A

4.1 Field of application

This method is intended mainly for samples of film or paper in sheet form or in rolls which do not show cupping, but curl in only the L, T or D directions.

4.2 Specimen size

Prepare at least three square specimens, measuring from 50 mm x 50 mm to 100 mm x 100 mm, from each sample to be tested. Alternatively, circular specimens measuring from 50 mm to 100 mm in diameter can be used. Indicate the machine direction, if known.

For analytical purposes, or for specimens that show cupping or varying curl along the length or width, specimens measuring 50 mm x 5 mm can be used, with the specimen cut in both the L and T directions.

4.3 Unit of curl measurement

The curl values are expressed as $1/R$, where R is the radius of curvature in metres.

4.4 Apparatus

4.4.1 Curl-board template, marked off with curves corresponding to various values of the reciprocal radius. It may be one of several formats (see Figure 2).

4.4.2 Specimen clamp, consisting of two vertical members of which the one facing the concave side of the specimen shall be approximately 3 mm in radius. In no case shall this radius exceed the radius of the curled specimen.

4.5 Procedure

At the end of the conditioning period and without removing the specimens from the conditioned atmosphere, secure each specimen above or below the template (4.4.1) by clamping so that the axis of curl is vertical. At least 10 mm of film should be held within the clamp (4.4.2).

Films of low stiffness may require a larger clamped area to avoid drooping due to gravity.

Note the curl value of the curve most nearly coinciding with the curl of the specimen.

ITeCh STANDARD PREVIEW
(standards.iteh.ai)

5 Test method B

ISO 18910:2000

5.1 Field of application <https://standards.iteh.ai/catalog/standards/sist/b00cb0b8-377d-4ec6-aaa4-277ea1ebff70/iso-18910-2000>

This method is intended for long lengths of film in roll form. It provides a means for measuring curl as it is found in use.

The curl is measured only in the cross-direction. It is purely a practical type of measurement and is not intended to distinguish the factors that cause curl.

5.2 Specimen size

Test specimens in standard widths, e.g. 8 mm, 16 mm, 32 mm, 35 mm, 70 mm, 105 mm, etc. Select at least three specimens from each sample to be tested.

The specimen length should be at least six times the film width.

5.3 Apparatus

5.3.1 Suitable depth or height gauge, graduated in millimetres, capable of reading the edge curl of film strips (see Figure 3).

5.4 Procedure

Place the strips to be measured on a horizontal surface at the end of the conditioning period, without removing them from the conditioning atmosphere. If necessary, hold the strip down at each end.

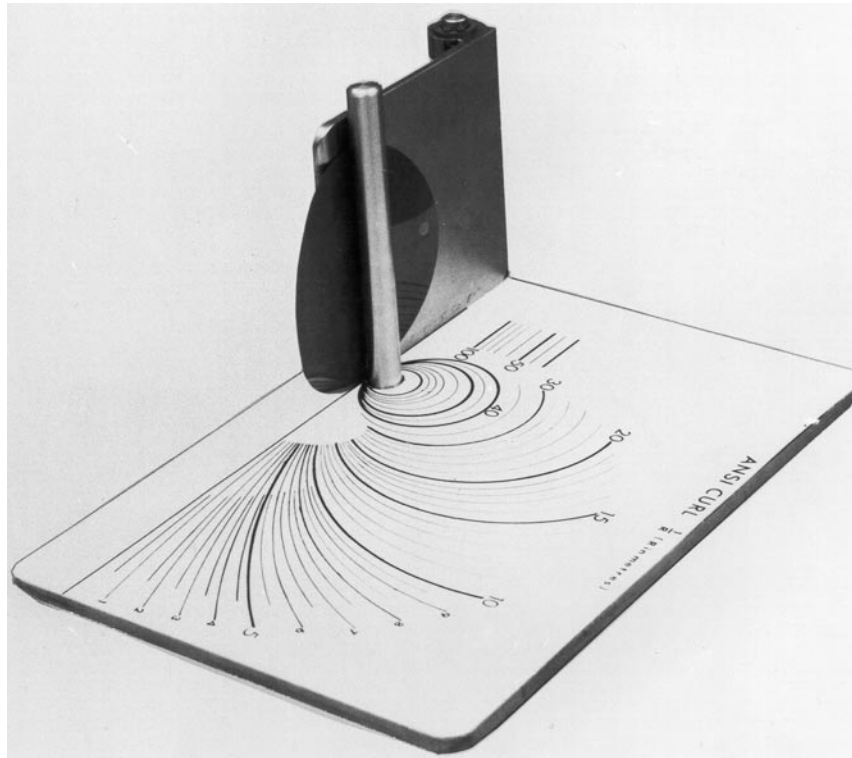

Arrange the clamp to hold the edge of the film on a line normal to the curves making up the measuring template. These curves may be computed as defined in 4.3.

(standards.iteh.ai)

a) Type I

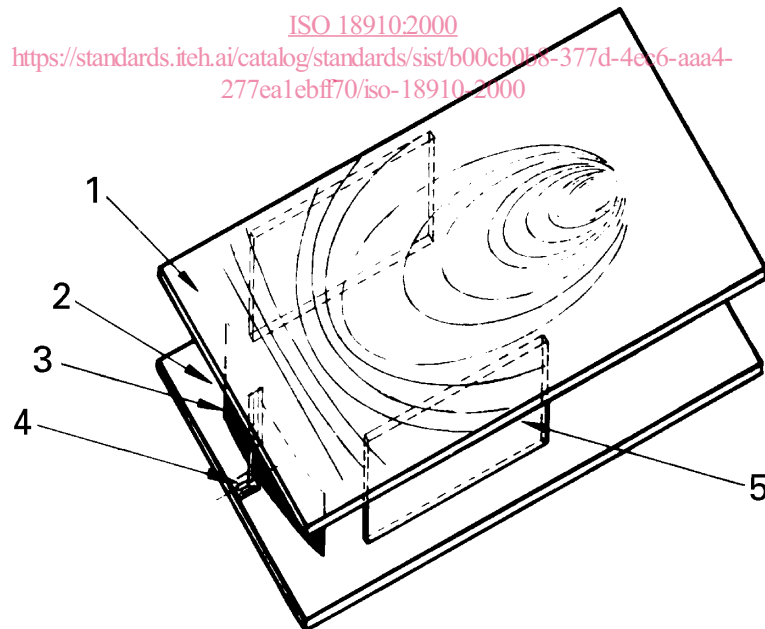

b) Type II

Key

- 1 Transparent template
- 2 Base plate
- 3 Sample
- 4 Sample holder
- 5 Vertical support

Figure 2 — Curl-board templates for measuring curl in accordance with test method A