



**SLOVENSKI STANDARD
SIST EN 299:2009**

01-december-2009

**BUXca Yý U
SIST EN 299:2000**

H'U bY'ycVY'nUfUhd'fYj Ub'Y'c`'Udf'] [cf]b_l `!' [cHUj`'Ub'Y'_cHU]b'fUhd'fYj Ub] \nbU]bcgh

Oil pressure atomizing nozzles - Determination of the angle and spray characteristics

Öldruckzerstäuberdüsen - Prüfung der Sprühcharakteristik und des Winkels

Gicleurs sans retour pour brûleurs à foyou domestique à pulvérisation - Détermination de l'angle et des caractéristiques de pulvérisation

[SIST EN 299:2009](#)

<https://standards.iteh.ai/catalog/standards/sist/76dc6820-81a2-46ca-b220-150d3a>

Ta slovenski standard je istoveten z: EN 299:2009

ICS:

27.060.10 Ö[|ä] ä ä ä ä \ [^ Ä Ä ä [Liquid and solid fuel burners
* [|ä]

SIST EN 299:2009

en,fr,de

iTeh STANDARD PREVIEW
(standards.iteh.ai)

SIST EN 299:2009

<https://standards.iteh.ai/catalog/standards/sist/76dc6820-81a2-46ca-b220-6123c2150d3a/sist-en-299-2009>

EUROPEAN STANDARD
NORME EUROPÉENNE
EUROPÄISCHE NORM

EN 299

August 2009

ICS 27.060.10

Supersedes EN 299:1998

English Version

Oil pressure atomizing nozzles - Determination of the angle and spray characteristics

Gicleurs sans retour pour brûleurs à fioul domestique à pulvérisation - Détermination de l'angle et des caractéristiques de pulvérisation

Öldruckzerstäuberdüsen - Prüfung der Sprühcharakteristik und des Winkels

This European Standard was approved by CEN on 23 July 2009.

CEN members are bound to comply with the CEN/CENELEC Internal Regulations which stipulate the conditions for giving this European Standard the status of a national standard without any alteration. Up-to-date lists and bibliographical references concerning such national standards may be obtained on application to the CEN Management Centre or to any CEN member.

This European Standard exists in three official versions (English, French, German). A version in any other language made by translation under the responsibility of a CEN member into its own language and notified to the CEN Management Centre has the same status as the official versions.

CEN members are the national standards bodies of Austria, Belgium, Bulgaria, Cyprus, Czech Republic, Denmark, Estonia, Finland, France, Germany, Greece, Hungary, Iceland, Ireland, Italy, Latvia, Lithuania, Luxembourg, Malta, Netherlands, Norway, Poland, Portugal, Romania, Slovakia, Slovenia, Spain, Sweden, Switzerland and United Kingdom.

[SIST EN 299:2009](https://standards.iteh.ai/catalog/standards/sist/76dc6820-81a2-46ca-b220-6123c2150d3a/sist-en-299-2009)

<https://standards.iteh.ai/catalog/standards/sist/76dc6820-81a2-46ca-b220-6123c2150d3a/sist-en-299-2009>



EUROPEAN COMMITTEE FOR STANDARDIZATION
COMITÉ EUROPÉEN DE NORMALISATION
EUROPÄISCHES KOMITEE FÜR NORMUNG

Management Centre: Avenue Marnix 17, B-1000 Brussels

Contents

Page

Foreword.....	3
1 Scope	4
2 Normative references	4
3 Terms and definitions	4
4 Testing	4
4.1 Testing of the radial distribution/spray pattern	4
4.1.1 Test equipment	4
4.1.2 Test procedure	5
4.1.3 Processing of test data	5
4.1.4 Spray uniformity and angle ratio.....	5
4.1.5 Classification of pattern types	5
4.2 Testing of the index angle	5
4.2.1 Test equipment	5
4.2.2 Test procedure	6
4.2.3 Processing of test data	6
4.2.4 Computation of index angle	6
4.3 Explanations.....	9

ITeH STANDARD PREVIEW
(standards.iteh.ai)

SIST EN 299:2009

<https://standards.iteh.ai/catalog/standards/sist/76dc6820-81a2-46ca-b220-6123c2150d3a/sist-en-299-2009>

Foreword

This document (EN 299:2009) has been prepared by Technical Committee CEN/TC 47 “Atomizing oil burners and their components - Function - Safety - Testing”, the secretariat of which is held by DIN.

This European Standard shall be given the status of a national standard, either by publication of an identical text or by endorsement, at the latest by February 2010, and conflicting national standards shall be withdrawn at the latest by February 2010.

Attention is drawn to the possibility that some of the elements of this document may be the subject of patent rights. CEN [and/or CENELEC] shall not be held responsible for identifying any or all such patent rights.

This document supersedes EN 299:1998.

The main change from the previous edition is that the test equipment in Figure 1 is now dimensioned.

According to the CEN/CENELEC Internal Regulations, the national standards organizations of the following countries are bound to implement this European Standard: Austria, Belgium, Bulgaria, Cyprus, Czech Republic, Denmark, Estonia, Finland, France, Germany, Greece, Hungary, Iceland, Ireland, Italy, Latvia, Lithuania, Luxembourg, Malta, Netherlands, Norway, Poland, Portugal, Romania, Slovakia, Slovenia, Spain, Sweden, Switzerland and the United Kingdom.

ITEH STANDARD PREVIEW
(standards.iteh.ai)

SIST EN 299:2009

<https://standards.iteh.ai/catalog/standards/sist/76dc6820-81a2-46ca-b220-6123c2150d3a/sist-en-299-2009>

EN 299:2009 (E)**1 Scope**

This European Standard specifies a method for the determination of the spray characteristic and the index angle of oil pressure atomizing nozzles.

2 Normative references

The following referenced documents are indispensable for the application of this document. For dated references, only the edition cited applies. For undated references, the latest edition of the referenced document (including any amendments) applies.

EN 293, *Oil pressure atomizing nozzles – Minimum requirements – Testing*

3 Terms and definitions

For the purposes of this document, the following terms and definitions apply:

3.1 radial spray distribution-spray angle
variation in liquid flux when proceeding from the nozzle axis to the edge of the conical spray pattern at a specified distance from the atomizer

3.2 index angle
 Y
plane angle formed by a conical spray, wherein the magnitude of the angle is determined by a specified percentage, e.g. 80 %, of the total volume of liquid collected in a radial patternator

3.3 cumulative volume
aggregate volume of liquid, expressed as a percentage of the total volume collected in a radial patternator, when proceeding from the spray axis (centre of the patternator) to the edge of the spray pattern

3.4 radial patternator
device comprising a series of concentric annular compartments with a row of collection cylinders that is capable of measuring the radial spray distribution, as defined in 3.1

3.5 index
arbitrary number assigned to a group of oil burner nozzles having similar spray patterns

EXAMPLE "I" indicating "solid", see Table 1.

4 Testing**4.1 Testing of the radial distribution/spray pattern****4.1.1 Test equipment**

The radial patternator, as shown in Figures 1 and 2, shall be a cylindrical vessel having a bottom plate comprising 14 concentric dividers that provide annular compartments from which liquid may be drained into graduated collection cylinders.

During testing, the top of the vessel shall be covered with a lid at whose centre a nozzle holder shall be mounted, which shall be vertically adjustable, so that the specified distance can be maintained between the nozzle orifice and the upper bevelled edges of the dividers.

Means shall be taken to ensure that the annular compartments and collection cylinders are not exposed to the spray prior or subsequent to the period designated for the collection of liquid.

4.1.2 Test procedure

The nozzle to be tested shall be mounted in the nozzle holder. The latter shall be adjusted so that the axial distance between the nozzle orifice and the upper edges of the dividers is 50 mm.

Testing shall be conducted with a reference oil as specified by EN 293. The total volume atomized during each test shall be at least 80 ml and shall in any case be sufficient to provide representative quantities of liquid in the collection cylinders.

At the conclusion of each test, the liquid volumes in each cylinder shall be recorded.

4.1.3 Processing of test data

The recorded liquid volumes shall be tabulated along with the corresponding cumulative percentage volumes (see Table 3). Using the listed plane angles for each annular compartment, the cumulative volume (starting at the centre of the patternator) may be correlated with the plane angle subtended by that volume. Using this procedure, the continuous radial distribution may be represented in tabular or graphical form.

4.1.4 Spray uniformity and angle ratio

The radial mass-distribution is a measure of spatial uniformity at a specified distance from the atomizer. For example, a nozzle with "solid" spray pattern is relatively uniform, whereas a nozzle with "hollow" spray pattern is characterized by a high concentration of liquid at the outside of the spray cane.

An indication of uniformity or pattern type can be given by calculating the 50 % / 80 % angle ratio. The two angles which correspond to the 50 % and 80 % cumulative volumes respectively may be determined by linear interpolation between the values (see Table 3) that bracket the 50 % and 80 % points in Table 3 (see 4.2.4).

4.1.5 Classification of pattern types

The defined angle ratio shall be the basis for classifying spray pattern to the arbitrary indices in Table 1.

Table 1

Index	50 % / 80 % angle ratio	Qualitative description of spray pattern
I	> 0,700	solid
II	0,700 to 0,749	semi-solid
III	0,750 to 0,799	semi-hollow
IV	≥ 0,800	hollow

4.2 Testing of the index angle

4.2.1 Test equipment

See 4.1.1.

EN 299:2009 (E)

4.2.2 Test procedure

See 4.1.2.

4.2.3 Processing of test data

See 4.1.3.

4.2.4 Computation of index angle

The index angle for this standard is quantitatively defined as the 80 % angle. This is the angle according to Equation (1) corresponding to the inner angle where 80 % of the liquid volume is collected.

$$Y = \alpha + \left[\frac{(\beta - \alpha) \cdot (V - V_1)}{(V_2 - V_1)} \right] \quad (1)$$

where

Y is the index angle;

V is 50 %, if the 50 % index angle is to be computed, 80 %, if the 80 % index angle is to be computed;

V_1 is the cumulative volume in percent collected in all patternator compartments up to and including the compartment such that V_1 is as large as possible without exceeding the value of 80 %, if the 80 % angle is computed, or without exceeding 50 %, if the 50 % angle is computed;

V_2 is the cumulative volume in percent collected in all patternator compartments up to and including the compartment such that V_2 is as small as possible but still exceeds the value of 80 %, if the 80 % angle is computed, or still exceeds the value of 50 %, if the 50 % is computed;

α is the plane angle subtended by outer edge of compartment corresponding to V_1 ;

β is the plane angle subtended by outer edge of compartment corresponding to V_2 .

Table 2

Angle marking degrees	Tested angle degrees
50	45 to 55
60	56 to 65
70	66 to 75
80	76 to 85
90	86 to 95
100	96 to 105

Dimensions in millimetres

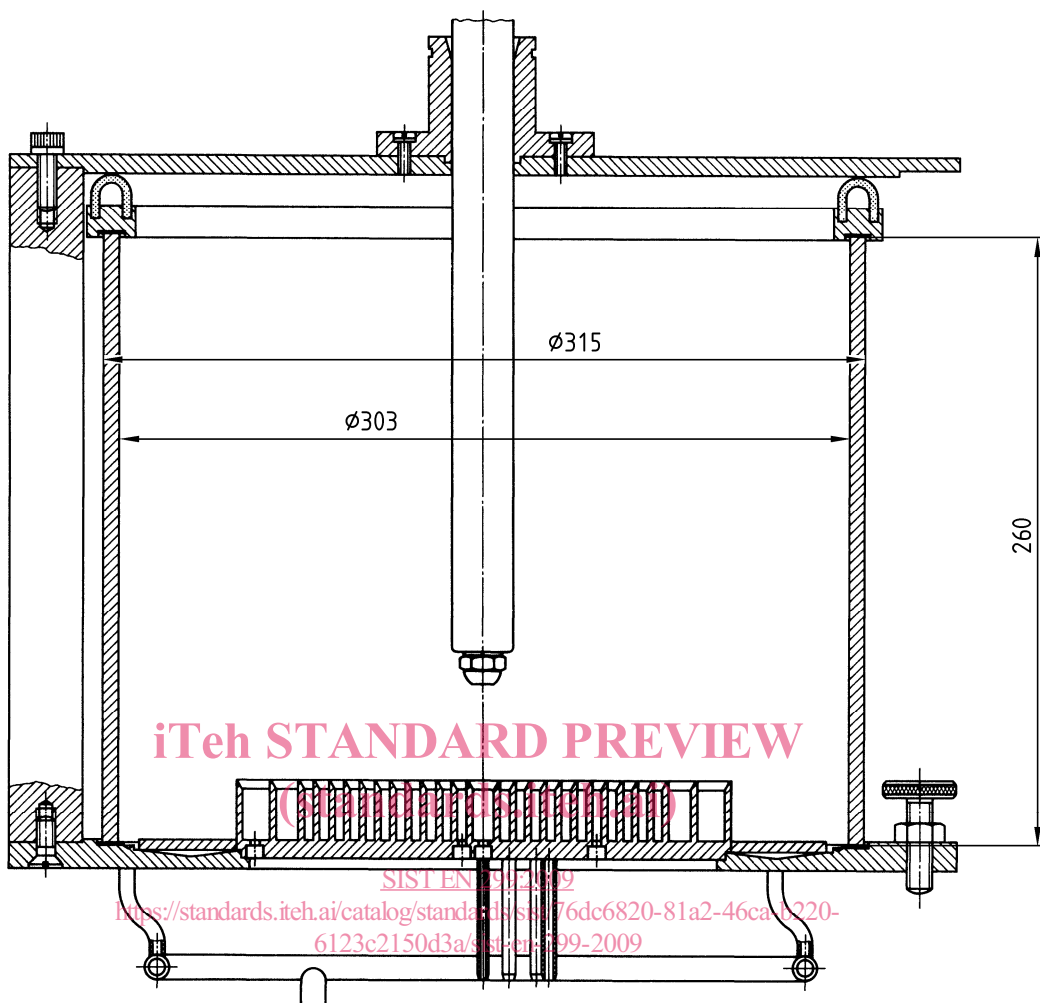

Figure 1