**Rolling bearings — Accessories —
Part 2:
Locknuts and locking devices —
Dimensions**

*Roulements — Accessoires —
Partie 2: Écrous à encoches et dispositifs de blocage — Dimensions*
(standards.iteh.ai)

[ISO 2982-2:2001](https://standards.iteh.ai/catalog/standards/sist/04f0b10f-fa17-463c-8c76-ab01f149d8e7/iso-2982-2-2001)

<https://standards.iteh.ai/catalog/standards/sist/04f0b10f-fa17-463c-8c76-ab01f149d8e7/iso-2982-2-2001>



PDF disclaimer

This PDF file may contain embedded typefaces. In accordance with Adobe's licensing policy, this file may be printed or viewed but shall not be edited unless the typefaces which are embedded are licensed to and installed on the computer performing the editing. In downloading this file, parties accept therein the responsibility of not infringing Adobe's licensing policy. The ISO Central Secretariat accepts no liability in this area.

Adobe is a trademark of Adobe Systems Incorporated.

Details of the software products used to create this PDF file can be found in the General Info relative to the file; the PDF-creation parameters were optimized for printing. Every care has been taken to ensure that the file is suitable for use by ISO member bodies. In the unlikely event that a problem relating to it is found, please inform the Central Secretariat at the address given below.

iTeh STANDARD PREVIEW
(standards.iteh.ai)

ISO 2982-2:2001

<https://standards.iteh.ai/catalog/standards/sist/04f0b10f-fa17-463c-8c76-ab01f149d8e7/iso-2982-2-2001>

© ISO 2001

All rights reserved. Unless otherwise specified, no part of this publication may be reproduced or utilized in any form or by any means, electronic or mechanical, including photocopying and microfilm, without permission in writing from either ISO at the address below or ISO's member body in the country of the requester.

ISO copyright office
Case postale 56 • CH-1211 Geneva 20
Tel. + 41 22 749 01 11
Fax + 41 22 749 09 47
E-mail copyright@iso.ch
Web www.iso.ch

Printed in Switzerland

Foreword

ISO (the International Organization for Standardization) is a worldwide federation of national standards bodies (ISO member bodies). The work of preparing International Standards is normally carried out through ISO technical committees. Each member body interested in a subject for which a technical committee has been established has the right to be represented on that committee. International organizations, governmental and non-governmental, in liaison with ISO, also take part in the work. ISO collaborates closely with the International Electrotechnical Commission (IEC) on all matters of electrotechnical standardization.

International Standards are drafted in accordance with the rules given in the ISO/IEC Directives, Part 3.

Draft International Standards adopted by the technical committees are circulated to the member bodies for voting. Publication as an International Standard requires approval by at least 75 % of the member bodies casting a vote.

Attention is drawn to the possibility that some of the elements of this part of ISO 2982 may be the subject of patent rights. ISO shall not be held responsible for identifying any or all such patent rights.

International Standard ISO 2982-2 was prepared by Technical Committee ISO/TC 4, *Rolling bearings*.

This second edition cancels and replaces the first edition (ISO 2982:1995), which has been technically revised.

ISO 2982 consists of the following parts, under the general title *Rolling bearings — Accessories*:

— *Part 1: Tapered sleeves — Dimensions*

— *Part 2: Locknuts and locking devices — Dimensions*

ISO 2982-2:2001
<https://standards.iteh.ai/catalog/standards/sist/04f0b10f-fa17-463c-8c76-ab01f149d8e7/iso-2982-2-2001>

iTeh STANDARD PREVIEW
(standards.iteh.ai)

ISO 2982-2:2001

<https://standards.iteh.ai/catalog/standards/sist/04f0b10f-fa17-463c-8c76-ab01f149d8e7/iso-2982-2-2001>

Rolling bearings — Accessories —

Part 2:

Locknuts and locking devices — Dimensions

1 Scope

This part of ISO 2982 specifies dimensions for locknuts and locking devices for tapered sleeves and for threaded shafts. The sleeves are manufactured in accordance with ISO 2982-1.

In particular:

- locknuts for adapter sleeves and for axial location of bearing inner rings on shafts; they are also suitable for dismantling of withdrawal sleeves;
- lockwashers with straight inner tab for use with 4-slot locknuts;
- lockwashers with bent inner tab for use with 4-slot locknuts; they are intended to be used for threaded shafts;
- locking clip assemblies for use with 8-slot locknuts.

<https://standards.iteh.ai/catalog/standards/sist/04f0b10f-fa17-463c-8c76-ab01f149d8e7/iso-2982-2-2001>

2 Normative references

The following normative documents contain provisions which, through reference in this text, constitute provisions of this part of ISO 2982. For dated references, subsequent amendments to, or revisions of, any of these publications do not apply. However, parties to agreements based on this part of ISO 2982 are encouraged to investigate the possibility of applying the most recent editions of the normative documents indicated below. For undated references, the latest edition of the normative document referred to applies. Members of ISO and IEC maintain registers of currently valid International Standards.

ISO 965-3:1998, *ISO general purpose metric screw threads — Tolerances — Part 3: Deviations for constructional screw threads.*

ISO 2901:1993, *ISO metric trapezoidal screw threads — Basic profile and maximum material profiles.*

ISO 2982-1:1995, *Rolling bearings — Accessories — Part 1: Tapered sleeves — Dimensions.*

3 Symbols and dimensions

The symbols (except those for tolerances) shown in the figures and the values given in the tables denote nominal dimensions unless specified otherwise.

3.1 Locknuts (4 slots) and lockwashers

See Figures 1 and 2 and Tables 1, 2 and 3.

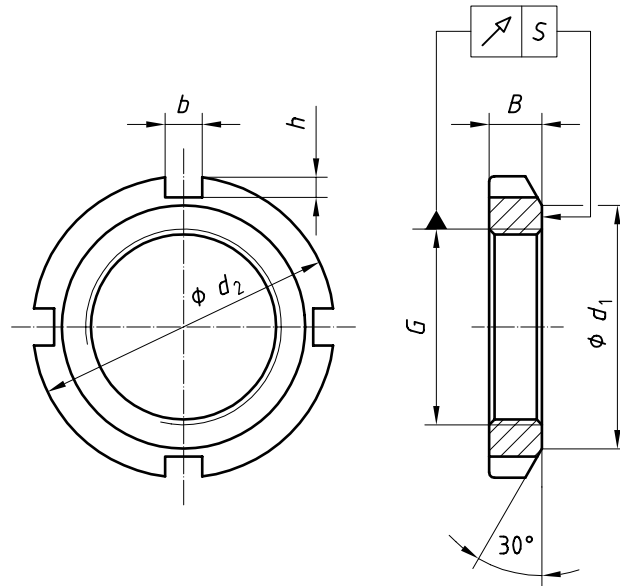

- b = width of slot in locknut
- B = locknut width
- d_1 = outside diameter of clamp face of locknut
- d_2 = outside diameter of locknut
- G = designation of screw thread
- h = depth of slot in locknut
- S = runout tolerance of locknut clamp face with respect to pitch diameter of screw thread

iTeh STANDARD PREVIEW
Figure 1 — Locknut (4 slots)
 (standards.iteh.ai)

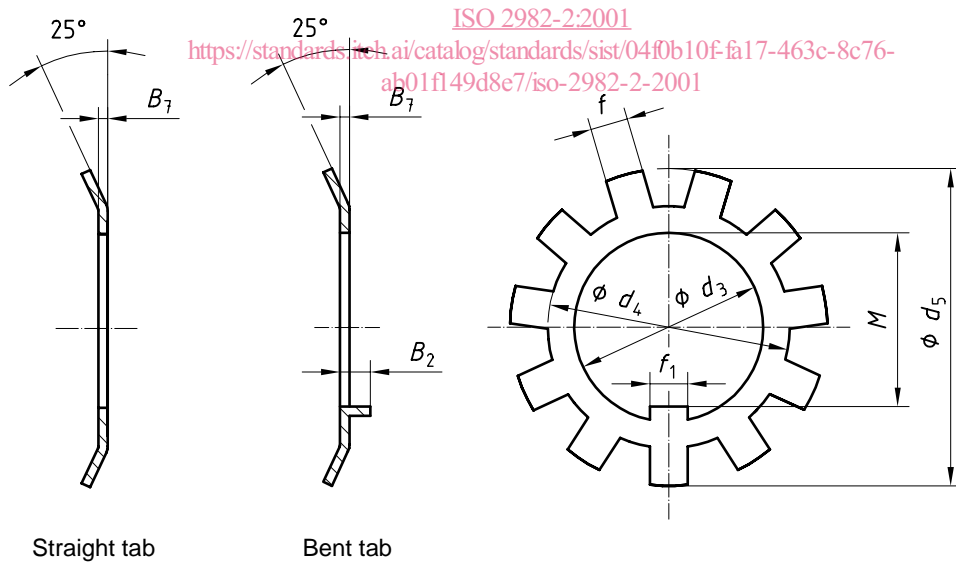

- B_2 = protrusion of inner tab of lockwasher
- B_7 = material thickness of lockwasher
- d_3 = bore diameter of lockwasher
- d_4 = root diameter of outer tab of lockwasher
- d_5 = outside diameter of lockwasher
- f = width of outer tab of lockwasher
- f_1 = width of inner tab of lockwasher
- M = d_3 – height of inner tab
- N = number of outer tabs of lockwasher

Figure 2 — Lockwashers

Table 1 — Locknuts (4 slots)

Dimensions in millimetres

G^a	d_2	d_1	B	b	h	S^b
M10 × 0,75	18	13,5	4	3	2	0,04
M12 × 1	22	17	4	3	2	
M15 × 1	25	21	5	4	2	
M17 × 1	28	24	5	4	2	
M20 × 1	32	26	6	4	2	
M25 × 1,5	38	32	7	5	2	
M30 × 1,5	45	38	7	5	2	
M35 × 1,5	52	44	8	5	2	
M40 × 1,5	58	50	9	6	2,5	
M45 × 1,5	65	56	10	6	2,5	
M50 × 1,5	70	61	11	6	2,5	0,05
M55 × 2	75	67	11	7	3	
M60 × 2	80	73	11	7	3	
M65 × 2	85	79	12	7	3	
M70 × 2	92	85	12	8	3,5	
M75 × 2	98	90	13	8	3,5	
M80 × 2	105	95	15	8	3,5	
M85 × 2	110	102	16	8	3,5	
M90 × 2	120	108	16	10	4	
M95 × 2	125	113	17	10	4	
M100 × 2	130	120	18	10	4	0,06
M105 × 2	140	126	18	12	5	
M110 × 2	145	133	19	12	5	
M115 × 2	150	137	19	12	5	
M120 × 2	145	135	20	12	5	
M120 × 2	155	138	20	12	5	
M125 × 2	160	148	21	12	5	
M130 × 2	155	145	21	12	5	
M130 × 2	165	149	21	12	5	
M135 × 2	175	160	22	14	6	
M140 × 2	165	155	22	12	5	0,12
M140 × 2	180	160	22	14	6	
M145 × 2	190	171	24	14	6	
M150 × 2	180	170	24	14	5	
M150 × 2	195	171	24	14	6	
M155 × 3	200	182	25	16	7	
M160 × 3	190	180	25	14	5	
M160 × 3	210	182	25	16	7	
M165 × 3	210	193	26	16	7	
M170 × 3	200	190	26	16	5	
M170 × 3	220	193	26	16	7	
M180 × 3	210	200	27	16	5	
M180 × 3	230	203	27	18	8	
M190 × 3	220	210	28	16	5	
M190 × 3	240	214	28	18	8	
M200 × 3	240	222	29	18	8	
M200 × 3	250	226	29	18	8	
Tr210 × 4	270	238	30	20	10	
Tr220 × 4	280	250	32	20	10	
Tr230 × 4	290	260	34	20	10	
Tr240 × 4	300	270	34	20	10	
Tr250 × 4	320	290	36	20	10	
Tr260 × 4	330	300	36	24	12	
Tr280 × 4	350	320	38	24	12	

^a Tolerance class 5H, ISO 965-3, for metric threads and 7H, ISO 2901, for metric trapezoidal threads.

^b Measurements taken at a radius = (Thread outside diameter + d_1) / 4.

Table 2 — Straight tab lockwashers

Dimensions in millimetres

d_3	d_4	d_5 ≈	f_1 max.	M	f^a	B_T^b ≈	N^c
10	13,5	21	3	8,5	3	1	9
12	17	25	3	10,5	3	1	11
15	21	28	4	13,5	4	1	
17	24	32	4	15,5	4	1	
20	26	36	4	18,5	4	1	
25	32	42	5	23	5	1,25	
30	38	49	5	27,5	5	1,25	
35	44	57	6	32,5	5	1,25	
40	50	62	6	37,5	6	1,25	
45	56	69	6	42,5	6	1,25	
50	61	74	6	47,5	6	1,25	15
55	67	81	8	52,5	7	1,5	
60	73	86	8	57,5	7	1,5	
65	79	92	8	62,5	7	1,5	
70	85	98	8	66,5	8	1,5	
75	90	104	8	71,5	8	1,5	16
80	95	112	10	76,5	8	1,8	
85	102	119	10	81,5	8	1,8	
90	108	126	10	86,5	10	1,8	
95	113	133	10	91,5	10	1,8	
100	120	142	12	96,5	10	1,8	17
105	126	145	12	100,5	12	1,8	
110	133	154	12	105,5	12	1,8	
115	137	159	12	110,5	12	2	
120	135	151	14	115	12	2	
120	138	164	14	115	12	2	18
125	148	170	14	120	12	2	
130	145	161	14	125	12	2	
130	149	175	14	125	12	2	
135	160	185	14	130	14	2	
140	155	171	16	135	12	2	19
140	160	192	16	135	14	2	
145	171	202	16	140	14	2	
150	170	188	16	145	14	2	
150	171	205	16	145	14	2	
155	182	212	16	147,5	16	2,5	20
160	180	199	18	154	14	2,5	
160	182	217	18	154	16	2,5	
165	193	222	18	157,5	16	2,5	
170	190	211	18	164	16	2,5	
170	193	232	18	164	16	2,5	21
180	200	221	20	174	16	2,5	
180	203	242	20	174	18	2,5	
190	210	231	20	184	16	2,5	
190	214	252	20	184	18	2,5	
200	222	248	20	194	18	2,5	22
200	226	262	20	194	18	2,5	
210	—	—	—	—	—	—	
220	250	292	24	213	20	3	
230	—	—	—	—	—	—	
240	270	312	24	233	20	3	23
250	—	—	—	—	—	—	
260	300	342	28	253	24	3	
260	—	—	—	—	—	—	
280	320	362	28	273	24	3	

^a f shall be $< b$ (see Figure 1 and Table 1).
^b The thickness is only approximate and small variations are permissible.
^c N = minimum number of outer tabs; since the locknut has 4 slots, N must be an odd number.

Table 3 — Bent tab lockwashers

Dimensions in millimetres

d_3	d_4	d_5 ≈	f_1 max.	f^a	B_2	B_7^b ≈	M	N^c
10	13,5	21	3	3	3	1	8,5	9
12	17	25	3	3	3	1	10,5	11
15	21	28	4	4	4	1	13,5	
17	24	32	4	4	4	1	15,5	
20	26	36	4	4	4	1	18,5	
22	28	38	4	4	4	1	20,5	
25	32	42	5	5	4	1,25	23	13
28	36	46	5	5	4	1,25	26	
30	38	49	5	5	4	1,25	27,5	
32	40	52	5	5	4	1,25	29,5	
35	44	57	6	5	4	1,25	32,5	
40	50	62	6	6	5	1,25	37,5	
45	56	69	6	6	5	1,25	42,5	
50	61	74	6	6	5	1,25	47,5	
55	67	81	8	7	5	1,5	52,5	17
60	73	86	8	7	6	1,5	57,5	
65	79	92	8	7	6	1,5	62,5	
70	85	98	8	8	6	1,5	66,5	
75	90	104	8	8	6	1,5	71,5	
80	95	112	10	8	6	1,8	76,5	
85	102	119	10	8	6	1,8	81,5	
90	108	126	10	10	8	1,8	86,5	
95	113	133	10	10	8	1,8	91,5	
100	120	142	10	10	8	1,8	96,5	
105	126	145	12	12	10	1,8	100,5	
110	133	154	12	12	10	1,8	105,5	
115	137	159	12	12	10	2	110,5	
120	138	164	14	12	10	2	115	
125	148	170	14	12	10	2	120	
130	149	175	14	12	10	2	125	
135	160	185	14	14	10	2	130	
140	160	192	16	14	10	2	135	
145	171	202	16	14	10	2	140	
150	171	205	16	14	10	2	145	
155	182	212	16	16	12	2,5	147,5	19
160	182	217	18	16	12	2,5	154	
165	193	222	18	16	12	2,5	157,5	
170	193	232	18	16	12	2,5	164	
180	203	242	20	18	12	2,5	174	
190	214	252	20	18	12	2,5	184	
200	226	262	20	18	12	2,5	194	
220	250	292	24	20	14	3	213	
240	270	312	24	20	14	3	233	
260	300	342	28	24	14	3	253	
280	320	362	28	24	14	3	273	

^a f shall be $< b$ (see Figure 1 and Table 1).

^b The thickness is only approximate and small variations are permissible.

^c N = minimum number of outer tabs; since the locknut has 4 slots, N must be an odd number.