



SLOVENSKI STANDARD
SIST ISO 492:2002

01-december-2002

Kotalni ležaji - Radialni ležaji - Tolerance

Rolling bearings -- Radial bearings -- Tolerances

Roulements -- Roulements radiaux -- Tolérances

Ta slovenski standard je istoveten z: ISO 492:2002

[SIST ISO 492:2002](https://standards.iteh.ai/catalog/standards/sist/645d53f4-b2d0-4c3e-a29f-1d937461b82f/sist-iso-492-2002)

<https://standards.iteh.ai/catalog/standards/sist/645d53f4-b2d0-4c3e-a29f-1d937461b82f/sist-iso-492-2002>

ICS:

21.100.20 Kotalni ležaji Rolling bearings

SIST ISO 492:2002

en

iTeh STANDARD PREVIEW
(standards.iteh.ai)

SIST ISO 492:2002

<https://standards.iteh.ai/catalog/standards/sist/645d53f4-b2d0-4c3e-a29f-1d937461b82f/sist-iso-492-2002>

INTERNATIONAL STANDARD

**ISO
492**

Fourth edition
2002-04-15

Rolling bearings — Radial bearings — Tolerances

Roulements — Roulements radiaux — Tolérances

iTeh STANDARD PREVIEW
(standards.iteh.ai)

[SIST ISO 492:2002](https://standards.iteh.ai/catalog/standards/sist/645d53f4-b2d0-4c3e-a29f-1d937461b82f/sist-iso-492-2002)

<https://standards.iteh.ai/catalog/standards/sist/645d53f4-b2d0-4c3e-a29f-1d937461b82f/sist-iso-492-2002>



Reference number
ISO 492:2002(E)

© ISO 2002

ISO 492:2002(E)

PDF disclaimer

This PDF file may contain embedded typefaces. In accordance with Adobe's licensing policy, this file may be printed or viewed but shall not be edited unless the typefaces which are embedded are licensed to and installed on the computer performing the editing. In downloading this file, parties accept therein the responsibility of not infringing Adobe's licensing policy. The ISO Central Secretariat accepts no liability in this area.

Adobe is a trademark of Adobe Systems Incorporated.

Details of the software products used to create this PDF file can be found in the General Info relative to the file; the PDF-creation parameters were optimized for printing. Every care has been taken to ensure that the file is suitable for use by ISO member bodies. In the unlikely event that a problem relating to it is found, please inform the Central Secretariat at the address given below.

iTeh STANDARD PREVIEW (standards.iteh.ai)

[SIST ISO 492:2002](#)

<https://standards.iteh.ai/catalog/standards/sist/645d53f4-b2d0-4c3e-a29f-1d937461b82f/sist-iso-492-2002>

© ISO 2002

All rights reserved. Unless otherwise specified, no part of this publication may be reproduced or utilized in any form or by any means, electronic or mechanical, including photocopying and microfilm, without permission in writing from either ISO at the address below or ISO's member body in the country of the requester.

ISO copyright office
Case postale 56 • CH-1211 Geneva 20
Tel. + 41 22 749 01 11
Fax + 41 22 749 09 47
E-mail copyright@iso.ch
Web www.iso.ch

Printed in Switzerland

Contents

Page

Foreword.....	iv
1 Scope	1
2 Normative references	1
3 Terms and definitions	1
4 Symbols	2
4.1 General.....	2
4.2 Symbols for boundary dimensions and running accuracy.....	2
4.3 Additional symbols for tapered roller bearings	4
5 Tolerances	5
5.1 Radial bearings except tapered roller bearings	5
5.1.1 General.....	5
5.1.2 Normal tolerance class	5
5.1.3 Tolerance class 6	7
5.1.4 Tolerance class 5	9
5.1.5 Tolerance class 4	10
5.1.6 Tolerance class 2	11
5.2 Tapered roller bearings	12
5.2.1 General.....	12
5.2.2 Normal tolerance class	12
5.2.3 Tolerance class 6 X	15
5.2.4 Tolerance class 5	16
5.2.5 Tolerance class 4	18
5.2.6 Tolerance class 2	20
5.3 Radial bearings, outer ring flanges	21
5.4 Basically tapered bores, tapers 1:12 and 1:30	22
Bibliography	25

ISO 492:2002(E)

Foreword

ISO (the International Organization for Standardization) is a worldwide federation of national standards bodies (ISO member bodies). The work of preparing International Standards is normally carried out through ISO technical committees. Each member body interested in a subject for which a technical committee has been established has the right to be represented on that committee. International organizations, governmental and non-governmental, in liaison with ISO, also take part in the work. ISO collaborates closely with the International Electrotechnical Commission (IEC) on all matters of electrotechnical standardization.

International Standards are drafted in accordance with the rules given in the ISO/IEC Directives, Part 3.

The main task of technical committees is to prepare International Standards. Draft International Standards adopted by the technical committees are circulated to the member bodies for voting. Publication as an International Standard requires approval by at least 75 % of the member bodies casting a vote.

Attention is drawn to the possibility that some of the elements of this International Standard may be the subject of patent rights. ISO shall not be held responsible for identifying any or all such patent rights.

ISO 492 was prepared by Technical Committee ISO/TC 4, *Rolling bearings*, Subcommittee SC 4, *Tolerances*.

This fourth edition cancels and replaces the third edition (ISO 492:1994), which has been technically revised.

TC4 STANDARD PREVIEW
(standards.iteh.ai)

SIST ISO 492:2002

<https://standards.iteh.ai/catalog/standards/sist/645d53f4-b2d0-4c3e-a29f-1d937461b82f/sist-iso-492-2002>

Rolling bearings — Radial bearings — Tolerances

1 Scope

This International Standard specifies tolerances for boundary dimensions (except chamfer dimensions) and the running accuracy of radial rolling bearings specified in ISO 15, ISO 355 and ISO 8443.

This International Standard does not apply to certain radial bearings of particular types (e.g., drawn cup needle roller bearings) or for particular fields of application (e.g., airframe bearings and instrument precision bearings). Tolerances for such bearings are given in the relevant International Standards.

Chamfer dimension limits are given in ISO 582.

2 Normative references

The following normative documents contain provisions which, through reference in this text, constitute provisions of this International Standard. For dated references, subsequent amendments to, or revisions of, any of these publications do not apply. However, parties to agreements based on this International Standard are encouraged to investigate the possibility of applying the most recent editions of the normative documents indicated below. For undated references, the latest edition of the normative document referred to applies. Members of ISO and IEC maintain registers of currently valid International Standards.

ISO 15:1998, *Rolling bearings — Radial bearings — Boundary dimensions, general plan*

ISO 355:1977, *Rolling bearings — Metric tapered roller bearings — Boundary dimensions and series designations*

ISO 582:1995, *Rolling bearings — Chamfer dimensions — Maximum values*

ISO 1132-1:2000, *Rolling bearings — Tolerances — Part 1: Terms and definitions*

ISO 5593:1997, *Rolling bearings — Vocabulary*

ISO 8443:1999, *Rolling bearings — Radial ball bearings with flanged outer ring — Flange dimensions*

ISO 15241:2001, *Rolling bearings — Symbols for quantities*

3 Terms and definitions

For the purposes of this International Standard, the terms and definitions given in ISO 1132-1 and ISO 5593 apply.

ISO 492:2002(E)

4 Symbols

4.1 General

For the purposes of this International Standard, the symbols given in ISO 15241 and the following apply.

The symbols (except those for tolerances) shown in Figures 1 to 4 and the values given in Tables 1 to 26 denote nominal dimensions unless specified otherwise.

4.2 Symbols for boundary dimensions and running accuracy

See Figure 1 for symbols for the dimensions.

B	inner ring width
V_{Bs}	variation of inner ring width
Δ_{Bs}	deviation of a single inner ring width
C	outer ring width
C_1	outer ring flange width
V_{Cs}	variation of outer ring width
V_{C1s}	variation of outer ring flange width
Δ_{Cs}	deviation of a single outer ring width
Δ_{C1s}	deviation of a single outer ring flange width
d	bore diameter
d_1	diameter at the theoretical large end of a basically tapered bore
V_{dmp}	variation of mean bore diameter (this applies only to a basically cylindrical bore)
V_{dsp}	variation of bore diameter in a single plane
Δ_{dmp}	deviation of mean bore diameter in a single plane (for a basically tapered bore, Δ_{dmp} refers to the theoretical small end of the bore)
Δ_{ds}	deviation of a single bore diameter
Δ_{d1mp}	deviation of mean bore diameter in a single plane at the theoretical large end of a basically tapered bore
D	outside diameter
D_1	outside diameter of outer ring flange
V_{Dmp}	variation of mean outside diameter
V_{Dsp}	variation of outside diameter in a single plane

Δ_{Ds}	deviation of a single outside diameter
Δ_{Dmp}	deviation of mean outside diameter in a single plane
Δ_{D1s}	deviation of a single outside diameter of outer ring flange
K_{ea}	radial runout of outer ring of assembled bearing
K_{ia}	radial runout of inner ring of assembled bearing
S_d	perpendicularity of inner ring face with respect to the bore
S_D	perpendicularity of outer ring outside surface with respect to the face
S_{D1}	perpendicularity of outer ring outside surface with respect to the flange back face
S_{ea}	axial runout of outer ring of assembled bearing
S_{ea1}	axial runout of outer ring flange back face of assembled bearing
S_{ia}	axial runout of inner ring of assembled bearing
α	angle of taper (half the cone angle) of inner ring bore

iTeh STANDARD PREVIEW
(standards.iteh.ai)

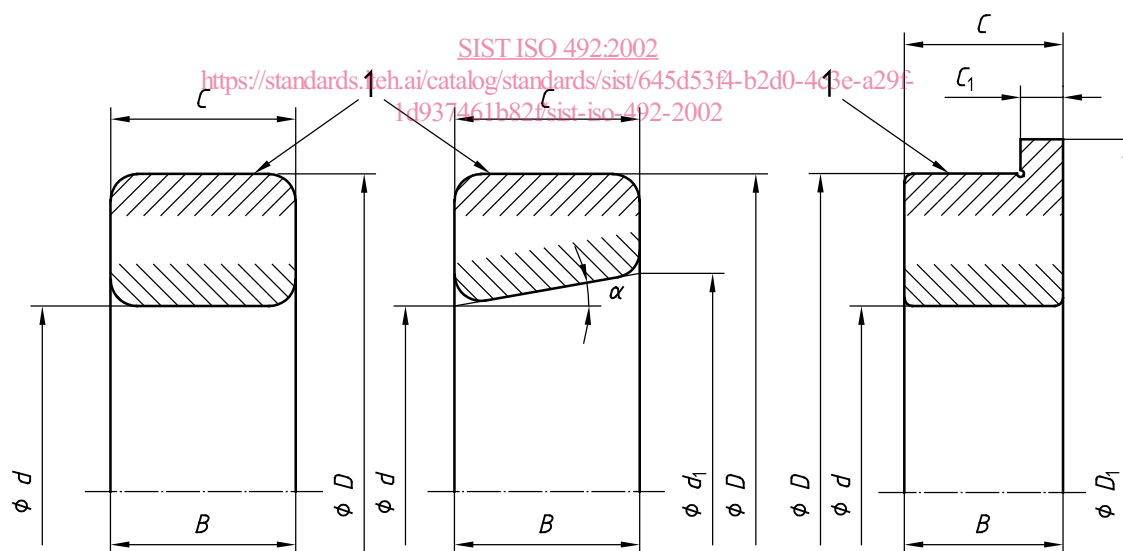

Key

- 1 Bearing outside surface

Figure 1 — Symbols for boundary dimensions

ISO 492:2002(E)

4.3 Additional symbols for tapered roller bearings

See Figure 2.

T	assembled bearing width
T_1	effective width of inner subunit
T_2	effective width of outer ring
ΔT_s	deviation of the actual (assembled) bearing width
ΔT_{1s}	deviation of the actual effective width of inner subunit
ΔT_{2s}	deviation of the actual effective width of outer ring

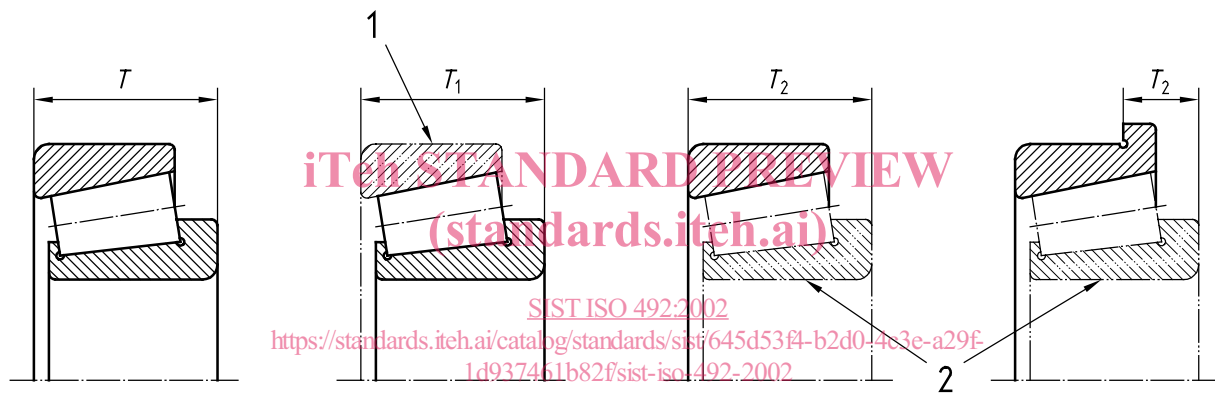
**Key**

- 1 Master outer ring
- 2 Master inner subunit

Figure 2 — Additional symbols for tapered roller bearings

5 Tolerances

5.1 Radial bearings except tapered roller bearings

5.1.1 General

The bore diameter tolerances given in this subclause apply to basically cylindrical bores. Tolerances for tapered bores are given in 5.4.

The diameter series referred to in Tables 1 to 8 are those defined in ISO 15.

5.1.2 Normal tolerance class

See Tables 1 and 2.

Table 1 — Inner ring

Tolerance values in micrometres

d mm		Δ_{dmp}		V_{dsp}			V_{dmp}	K_{ia}	Δ_{Bs}			V_{Bs}
				Diameter series					all	normal	modified ^a	
				9	0, 1	2, 3, 4						
>	≤	high	low	max.			max.	max.	high	low		max.
—	0,6	0	− 8	10	8	6	6	10	0	− 40	—	12
0,6	2,5	0	− 8	10	8	6	6	10	0	− 40	—	12
2,5	10	0	− 8	10	8	6	6	10	0	− 120	− 250	15
10	18	0	− 8	10	8	6	6	10	0	− 120	− 250	20
18	30	0	− 10	13	10	8	6	13	0	− 120	− 250	20
30	50	0	− 12	15	12	9	9	15	0	− 120	− 250	20
50	80	0	− 15	19	19	11	11	20	0	− 150	− 380	25
80	120	0	− 20	25	25	15	15	25	0	− 200	− 380	25
120	180	0	− 25	31	31	19	19	30	0	− 250	− 500	30
180	250	0	− 30	38	38	23	23	40	0	− 300	− 500	30
250	315	0	− 35	44	44	26	26	50	0	− 350	− 500	35
315	400	0	− 40	50	50	30	30	60	0	− 400	− 630	40
400	500	0	− 45	56	56	34	34	65	0	− 450	—	50
500	630	0	− 50	63	63	38	38	70	0	− 500	—	60
630	800	0	− 75	—	—	—	—	80	0	− 750	—	70
800	1 000	0	− 100	—	—	—	—	90	0	− 1 000	—	80
1 000	1 250	0	− 125	—	—	—	—	100	0	− 1 250	—	100
1 250	1 600	0	− 160	—	—	—	—	120	0	− 1 600	—	120
1 600	2 000	0	− 200	—	—	—	—	140	0	− 2 000	—	140

^a Applies to inner rings and outer rings of single bearings made for paired and stack assemblies. Also applies to inner rings with tapered bore with $d \geq 50$ mm.

Table 2 — Outer ring

Tolerance values in micrometres

D mm		Δ_{Dmp}		V_{Dsp}^a				V_{Dmp}^a	K_{ea}	Δ_{Cs}		V_{Cs}
				Open bearings		Capped bearings						
				Diameter series								
				9	0, 1	2, 3, 4	2, 3, 4					
>	\leq	high	low	max.				max.	max.	high	low	max.
—	2,5	0	− 8	10	8	6	10	6	15	Identical to Δ_{Bs} and V_{Bs} of inner ring of the same bearing as the outer ring.		
2,5	6	0	− 8	10	8	6	10	6	15			
6	18	0	− 8	10	8	6	10	6	15			
18	30	0	− 9	12	9	7	12	7	15			
30	50	0	− 11	14	11	8	16	8	20			
50	80	0	− 13	16	13	10	20	10	25			
80	120	0	− 15	19	19	11	26	11	35			
120	150	0	− 18	23	23	14	30	14	40			
150	180	0	− 25	31	31	19	38	19	45			
180	250	0	− 30	38	38	23	47	23	50			
250	315	0	− 35	44	44	26	—	26	60			
315	400	0	− 40	50	50	30	—	30	70			
400	500	0	− 45	56	56	34	—	34	80			
500	630	0	− 50	63	63	38	—	38	100			
630	800	0	− 75	94	94	55	—	55	120			
800	1 000	0	− 100	125	125	75	—	75	140			
1 000	1 250	0	− 125	—	—	—	—	—	160			
1 250	1 600	0	− 160	—	—	—	—	—	190			
1 600	2 000	0	− 200	—	—	—	—	—	220			
2 000	2 500	0	− 250	—	—	—	—	—	250			

NOTE The tolerances for the outside diameter D_1 of an outer ring flange are given in Table 24.

^a Applies before mounting and after removal of internal or external snap ring.

^b Applies to groove ball bearings only.