



# Standard Test Method for Evaluation of Engine Oils in Two-Stroke Cycle Turbo- Supercharged 6V92TA Diesel Engine<sup>1</sup>

This standard is issued under the fixed designation D 5862; the number immediately following the designation indicates the year of original adoption or, in the case of revision, the year of last revision. A number in parentheses indicates the year of last reapproval. A superscript epsilon ( $\epsilon$ ) indicates an editorial change since the last revision or reapproval.

## INTRODUCTION

This test method can be used by any properly equipped laboratory, without outside assistance. However, the ASTM Test Monitoring Center (TMC)<sup>2</sup> provides reference oils and an assessment of the test results obtained on those oils by the laboratory (see **Annex A1**). By this means, the laboratory will know whether their use of the test method gives results statistically similar to those obtained by other laboratories. Furthermore, various agencies require that a laboratory utilize the TMC services in seeking qualification of oils against specifications. For example, the U.S. Army imposes such a requirement, in connection with several Army engine lubricating oil specifications.

Accordingly, this test method is written for use by laboratories that utilize the TMC services. Laboratories that choose not to use those services may simply ignore those portions of the test method that refer to the TMC.

This test method may be modified by means of Information Letters issued by the TMC. In addition, the TMC may issue supplementary memoranda related to this test method. (See **Annex A1**.)

## 1. Scope

1.1 This test method<sup>3</sup> describes a two-stroke cycle diesel engine test procedure for evaluating engine oils for certain high-temperature performance characteristics, particularly cylinder liner scuffing and piston ring face distress, but also including port plugging, slipper bushing, and piston skirt distress. Such oils include both single viscosity SAE grade and multiviscosity SAE grade oils used in diesel engines. It is commonly known as the 6V92TA test. (See **Note 1**.)

**NOTE 1**—Companion test methods used to evaluate other engine oil performance characteristics for specification requirements are discussed in Engine Oil tests—**SAE J304**.

1.2 *This standard does not purport to address all of the safety concerns, if any, associated with its use. It is the responsibility of the user of this standard to establish appropriate safety and health practices and determine the applica-*

*bility of regulatory limitations prior to use.* Specific hazard statements are given in Sections **8**, **10**, **13**, and **14**.

1.3 The values stated in either SI units or inch-pound units are to be regarded separately as the standard. The values stated in each system may not be exact equivalents; therefore each system must be used independently of the other, without combining values in any way.

1.4 This test method is arranged as follows:

	Section
Scope	1
Referenced Documents	2
Terminology	3
Summary of Test Method	4
Significance and Use	5
Apparatus—General Description	6
Apparatus—Laboratory and Test Stand Requirements	7
Apparatus—Test Engine	8
Test Engine	8.1
Engine Parts	8.2
Special Cleaning Procedures	8.3
Periodic Maintenance Inspections	8.4
Engine Build-up Procedures	8.5
Measurement Instrumentation	9
Temperatures	9.1
Pressures	9.2
Reagents and Materials	10
Test Fuel	10.1
Test Oil	10.2
Coolant	10.3
Sealing and Anti-seize Compounds	10.4
Hazards	11
Laboratory and Test Stand Calibration	12

<sup>1</sup> This test method is under the jurisdiction of ASTM Committee D02 on Petroleum Products and Lubricants and is the direct responsibility of Subcommittee D02.B0 on Automotive Lubricants.

Current edition approved Nov. 1, 2003. Published December 2003. Originally approved in 1995. Last previous edition approved in 1999 as D 5862–99a.

<sup>2</sup> ASTM Test Monitoring Center, 6555 Penn Ave., Pittsburgh, PA 15206-4489. Fax number: 412-365-1045. Web page: <http://www.astmtmc.cmu.edu/>. This test method is supplemented by Information Letters and memoranda issued by the TMC. Users of this test method shall contact the TMC to obtain the most recent of these. This edition incorporates revisions in all Information Letters through No. 02–1.

<sup>3</sup> Supporting data have been filed at ASTM International Headquarters and may be obtained by requesting Research Report RR: D02-1319.

Test Procedure	13
Pre-Test Procedure	13.1
Engine Operating Procedure	13.2
Periodic Measurements and Functions	13.3
Diagnostic Data Review	13.4
End of Test Procedure	13.5
Interpretation of Test Results	14
Parts Rating Area—Environment	14.1
Piston Rings	14.2
Cylinder Liner	14.3
Piston Pin Slipper Bushing	14.4
Rocker Arm Bushing	14.6
Referee Rating	14.7
Preparation of Report	15
Test Numbering	15.1
Operational Data	15.2
Photographs	15.3
Electronic Transmission of Test Results	15.4
Precision and Bias	16
Keywords	17
Annexes	
ASTM Test Monitoring Center	A1
Detailed Specifications and Drawings of Apparatus	A2
Engine Part Number Listing	A3
Test Fuel Analysis	A4
Report Forms	A5
Data Dictionary	A6
Appendixes	
Oil Producers Affidavit	X1
English to Metric Conversion for the 6V92TA Test	X2
Engine Build-up Forms	X3

## 2. Referenced Documents

- 2.1 *ASTM Standards*:<sup>4</sup>
- D 86** Test Method for Distillation of Petroleum Products
  - D 92** Test Method for Flash and Fire Points by Cleveland Open Cup
  - D 240** Test Method for Heat of Combustion of Liquid Hydrocarbon Fuels by Bomb Calorimeter
  - D 287** Test Method for API Gravity of Crude Petroleum and Petroleum Products (Hydrometer Method)
  - D 445** Test Method for Kinematic Viscosity of Transparent and Opaque Liquids (and the Calculation of Dynamic Viscosity)
  - D 482** Test Method for Ash from Petroleum Products
  - D 613** Test Method for Cetane Number of Diesel Fuel Oil
  - D 2622** Test Method for Sulfur in Petroleum Products by X-Ray Spectrometry
  - D 2709** Test Method for Water and Sediment in Distillate Fuels by Centrifuge
  - D 2887** Test Method for Boiling Range Distribution of Petroleum Fractions by Gas Chromatography
  - D 4175** Terminology Relating to Petroleum, Petroleum Products, and Lubricants
  - D 4485** Specification for Performance of Engine Oils
  - D 4683** Test Method for Measuring Viscosity at High Temperature and High Shear Rate by Tapered Bearing Simulator
  - D 4739** Test Method for Base Number Determination by Potentiometric Titration
  - D 5185** Test Method for the Determination of Additive

Metals, Wear Metals and Contaminants in Used Lubricating Oils by Inductively-Coupled Plasma Atomic Emission Spectrometry

**E 344** Terminology Relating to Thermometry and Hydrometry

**G 40** Terminology Relating to Wear and Erosion

2.2 *SAE Standards*:<sup>5</sup>

**SAE J183** Engine Oil Performance and Engine Service Classification

**SAE J304** Engine Oil Tests

2.3 *Military Specifications*:<sup>6</sup>

**MIL-L-2104** Lubricating Oil, Internal Combustion Engine, Combat/Tactical Service

## 3. Terminology

3.1 *Definitions*:

3.1.1 *additive, n*—a material added to another, usually in small amounts, to impart or enhance desirable properties or to suppress undesirable properties. **D 4175**

3.1.2 *calibrate, v*—to determine the indication or output of a measuring device with respect to that of a standard. **E 344**

3.1.3 *candidate oil, n*—an oil which is intended to have the performance characteristics necessary to satisfy a specification and is to be tested against that specification. **D 5844**

3.1.4 *corrosion, n*—the chemical or electrochemical reaction between a material, usually a metal surface and its environment, that can produce a deterioration of the material and its properties. **D 5844**

3.1.5 *debris, n—in internal combustion engines*, solid contaminant materials unintentionally introduced into the engine or resulting from wear.

3.1.6 *engine oil, n*—a liquid that reduces friction or wear, or both, between the moving parts within an engine, removes heat, particularly from the underside of pistons; and serves as a combustion gas sealant for the piston rings.

3.1.6.1 *Discussion*—It may contain additives to enhance certain properties. Inhibition of engine rusting, deposit formation, valve train wear, oil oxidation and foaming are examples.

3.1.7 *free piston ring, n—in internal combustion engines*, a piston ring that will fall in its groove under its own weight when the piston, with the ring in a horizontal plane, is turned 90° (putting the ring in a vertical plane). **(Subcommittee B Glossary)**<sup>7</sup>

3.1.8 *heavy-duty, adj—in internal combustion engine operation*, characterized by average speeds, power output, and internal temperatures that are close to the potential maximums. **D 4485**

3.1.9 *heavy-duty engine, n—in internal combustion engines*, one that is designed to allow operation continuously at or close to its peak output. **D 4485**

<sup>4</sup> For referenced ASTM standards, visit the ASTM website, www.astm.org, or contact ASTM Customer Service at service@astm.org. For *Annual Book of ASTM Standards* volume information, refer to the standard's Document Summary page on the ASTM website.

<sup>5</sup> This standard is not available separately. Either order the SAE Handbook Vol 3, or the SAE Fuels and Lubricants Standards Manual HS 23 from: Society of Automotive Engineers, Inc., 400 Commonwealth Drive, Warrendale, PA 15096-0001.

<sup>6</sup> Available from the Standardization Documents Order Desk, Building 4, Section D, 700 Robbins Ave., Philadelphia, PA 19111-5094.

<sup>7</sup> Available from the Secretary of the ASTM D02.B0 Subcommittee.

3.1.10 *lubricant, n*—any material interposed between two surfaces that reduces the friction or wear, or both, between them.

3.1.11 *non-reference oil, n*—any oil other than a reference oil, such as a research formulation, commercial oil, or candidate oil. **D 5844**

3.1.12 *plugging, n*—the restriction of a flow path due to the accumulation of material along the flow path boundaries.

3.1.13 *reference oil*—an oil of known performance characteristics, used as a basis for comparison. **D 5844**

3.1.13.1 *Discussion*—Reference oils are used to calibrate testing facilities, to compare the performance of other oils, or to evaluate other materials (such as seals) that interact with oils.

3.1.14 *scoring, n—in tribology*, a severe form of wear characterized by the formation of extensive grooves and scratches in the direction of sliding. **G 40**

3.1.15 *scuffing, n—in lubrication*, damage caused by instantaneous localized welding between surfaces in relative motion which does not result in immobilization of the parts. **D 4863**

3.1.16 *soot, n—in internal combustion engines*, sub-micron size particles, primarily carbon, created in the combustion chamber as products of incomplete combustion.

3.1.17 *tight piston ring, n—in internal combustion engines*, a piston ring that will not fall in its groove under its own weight when the piston, with the ring in a horizontal plane, is turned 90° (putting the ring in a vertical plane); by subsequent application of moderate finger pressure, the ring will be displaced. **Subcommittee B Glossary<sup>7</sup>**

3.1.18 *used oil, n*—any oil that has been in a piece of equipment (for example, an engine, gearbox, transformer, or turbine), whether operated or not. **D 4175**

3.1.19 *wear, n*—the loss of material from, or relocation of material on, a surface.

3.1.19.1 *Discussion*—Wear generally occurs between two surfaces moving relative to each other, and is the result of mechanical or chemical action or by a combination of mechanical and chemical actions. **D 5302**

### 3.2 Definitions of Terms Specific to This Standard:

3.2.1 *liner scuffing, n*—scuffing characterized by vertical markings in the direction of piston motion which obscure visual detection of the honing crosshatch pattern of the liner.

3.2.2 *test, n*—any engine run-time accumulated beyond the break-in conducted according to this test method.

## 4. Summary of Test Method

4.1 A 500 horsepower 6V92TA diesel engine<sup>8</sup> is completely disassembled, solvent-cleaned, measured, and assembled using new parts as specified.

4.2 The engine is installed on a test stand equipped with the appropriate accessories for controlling speed, load, and various other engine operating parameters.

4.3 The engine is charged with the test oil and operated for 6 h and 10 min on a break-in cycle. An airbox inspection is

made after break-in to determine cylinder liner scuffing as a measure of the suitability of the engine build.

4.4 Following the break-in, the engine is operated under steady state conditions at both high load and high power for 7 cycles, totaling 100 h running time. Each cycle includes a heat soak and cool-down portion. This test stresses the lubricant thermally and mechanically to duplicate the service typical of these types of engines in use today.

4.5 Used oil samples are taken every 16 h with viscometric characteristics, metals, and base number (TBN) measured on a fixed schedule.

4.6 At the end of the test, the engine is disassembled, and the rings, liners, slipper bushings, and piston skirts are visually inspected for those signs of distress that relate to overall engine life.

## 5. Significance and Use

5.1 This test method was developed to evaluate diesel engine oils for protection against ring and liner distress caused by high thermal and mechanical loading.

5.2 Liner scuffing and ring distress experienced in this test method are measures of the oil's ability to protect against scuffing and scoring under high power and high load conditions typical of service experienced by engines in use today.

5.3 Piston pin slipper bushing wear, piston skirt tin removal, and liner port plugging are also examined in this test for distress which relates to overall engine life.

5.4 This test method was developed to correlate with field experience using oils of known good and poor protection against ring and liner distress.

5.5 The 6V92TA engine oil test is used in specifications and classifications of engine lubricating oils, such as the following:

5.5.1 Specification **D 4485**,

5.5.2 Military Specification **MIL-L-2104**, and

5.5.3 SAE Classification **J 183**.

## 6. Apparatus—General Description

6.1 The test engine is based on an 9 L Detroit Diesel 6V92TA, turbo-supercharged, aftercooled, two-stroke cycle diesel engine.

6.2 Use an engine test stand equipped to control engine speed and load, various temperatures, and other parameters.

6.3 Use appropriate air conditioning or heating apparatus, or both, as necessary to control the temperature of the intake air.

6.4 Use an appropriate fuel supply system.

## 7. Apparatus—Laboratory and Test Stand Requirements

7.1 *Laboratory*—Observe the following laboratory conditions to ensure good control of test operations and good repeatability:

7.1.1 Maintain the ambient laboratory atmosphere relatively free of dirt, dust, and other contaminants.

7.1.2 Control the temperature of the room in which parts measurements are made so that the temperature for after-test measurements is within a range of  $\pm 3^{\circ}\text{C}$  ( $\pm 5^{\circ}\text{F}$ ) relative to the temperature for the before-test measurements. If difficulty of parts fit during engine assembly is encountered, consider the effects of temperature coefficient of expansion.

<sup>8</sup> A Detroit Diesel 6V92TA engine shall be used; purchase it from a local Detroit Diesel Distributor. If it is necessary to locate a distributor, contact the Test Developer: Attention: Sequence 6V92TA Test Developer, Detroit Diesel Corporation, Fuels and Lubricants, 13400 West Outer Drive, Detroit, MI 48239-4001.

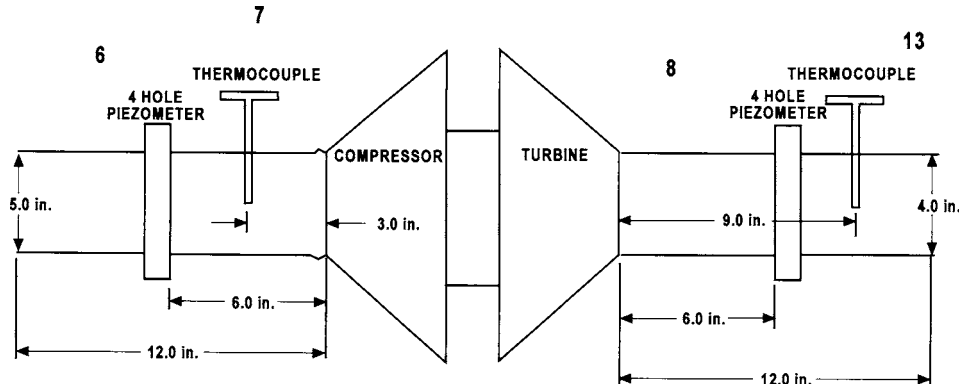

FIG. 1 Inlet and Exhaust Pressure and Temperature Sensor Locations

7.2 Engine Stand Requirements—A typical test stand is shown in Annex A2 (Fig. A2.1).

7.2.1 Engine Speed and Load Control—Dynamometer shall be able to maintain engine speeds of 1200 and 2300 r/min at the torques of 1850 N·m and 1550 N·m, respectively (approximately 373 kW). Load ramping is not required.

7.2.2 Engine Cooling System—Use a suitable external engine cooling system to maintain the specified engine coolant temperature during both the operating and cool-down portions of the test. The system shall incorporate the following features:

7.2.2.1 Cooling capacity of 370 kW (21 000 Btu/min).

7.2.2.2 Flow capacity of 760 L/min (200 gal/min).

7.2.2.3 Temperature control with coolant out temperature maintained at  $84 \pm 2^\circ\text{C}$  ( $183 \pm 4^\circ\text{F}$ ).

7.2.3 Air Inlet System:

7.2.3.1 Shall have a capacity of 34 m<sup>3</sup>/min (1200 cfm), at a temperature of  $35 \pm 3^\circ\text{C}$  ( $95 \pm 5^\circ\text{F}$ ).

7.2.3.2 Shall utilize 13-cm (5-in.) inside diameter pipe as shown in Fig. 1.

7.2.3.3 Shall have an air inlet restriction of  $2.5 \pm 0.7$  kPa ( $10 \pm 3$  in. H<sub>2</sub>O).

7.2.4 Exhaust System:

7.2.4.1 Shall have a flow capacity of 85 m<sup>3</sup>/min (3000 cfm) at  $510^\circ\text{C}$  ( $950^\circ\text{F}$ ).

7.2.4.2 Shall utilize a 10-cm (4-in.) inside diameter pipe as shown in Fig. 1.

7.2.4.3 Shall have backpressure of  $3.2 \pm 0.8$  kPa ( $0.95 \pm 0.25$  in. Hg).

7.2.5 External Oil Cooling System—Incorporate the external oil cooling system shown in Annex A2 (Fig. A2.2). A bracket for this system is shown in Annex A2 (Fig. A2.3). The oil gallery set-point is to be  $102 \pm 1^\circ\text{C}$  ( $216 \pm 2^\circ\text{F}$ ) during the load mode, and  $111 \pm 1^\circ\text{C}$  ( $232 \pm 2^\circ\text{F}$ ) during the power mode. The table in Annex A2 (A2.1) describes the parts required for the external cooler.

7.2.6 Adjustable Dipstick—Shall be used to monitor oil consumption. The construction of this dipstick is shown in Annex A2 (Fig. A2.4).

7.2.7 Fuel System—Use a fuel system with 11 500 L (3000 gal) capacity. It shall have a mass flow capability of 92 kg/h (202 lbm/h) minimum.

7.3 Drawings—Obtain the equipment drawings referenced in the Annex A1 of this test method from the ASTM Test Monitoring Center. Because the drawings may not be to scale,

when using them to fabricate special parts, use the dimensions specified. Do not use a drawing as a pattern. Drawing dimensions are considered to be correct when the temperature of the equipment is  $22^\circ\text{C}$  ( $72^\circ\text{F}$ ), unless otherwise specified.

7.4 Specified Equipment—Use the equipment specified in the procedure whenever possible. Substitution of equivalent equipment is allowed, but only after equivalency has been proven to the satisfaction of the ASTM Test Monitoring Center. See Annex A2 (Fig. A2.1) for a view of the engine and attached apparatus used in this test method.

## 8. Apparatus—Test Engine

8.1 Test Engine—Detroit Diesel 6V92TA 9 L500 horsepower (rating for evaluation of lubricants) turbo-supercharged, aftercooled, two-stroke cycle diesel engine is procured from the recommended source.<sup>8</sup> Rebuild the engine as specified in this test method. It is based on the Industrial Engine Model Number 8063-7408 which has the power rating of 410 kW (550 bhp) at 2300 r/min. Engine timing: 1.484 in., Lash 0.016 in.

8.2 Engine Parts—Engine parts which are to be used for intermittent overhauls required in conducting this test procedure are listed in Annex A3. Critical parts are discussed under 8.2.4 and 8.2.5. Subassemblies are listed by complete subassemblies only; not by parts making up the subassemblies. Such parts are not replaced routinely and can be obtained from the Detroit Diesel Distributor.

8.2.1 Use all engine parts as received from the supplier; either the special kits from the Detroit Diesel Distributor (see 8.2.4), or original equipment manufactured by Detroit Diesel, unless defects in the parts require that they be returned to the supplier.

8.2.2 Do not divert to other applications parts obtained for use in 6V92TA testing.

8.2.3 Special tools are required for overhaul and measurement of the engine. Unless otherwise specified in this standard, these tools are available from the supplier and part numbers are listed in the Service Manual.<sup>9</sup>

<sup>9</sup> Service Manuals, Sections 1–3 and Sections 4–15 are identified as 06SE0379 (two volumes) and can be purchased from Robot Printing Inc., Detroit Diesel Corporation, 25215 Glendale Ave., Redford, MI 48239-2675.



**TABLE 1 Replace Listed Parts Each Test**

Part Name	Part Number
Cylinder liner	23508937
Piston dome	23508938
Seal—dome to skirt	8923729
Piston skirt	23508940
Piston pin	5101120
Piston pin retainer	5180250
Slipper bushing	23501687
Oil control ring upper groove	23509097 top ring 23509098 bottom ring
Oil control ring lower groove	23509099 2 rings required
Oil ring expander	23509101
Fire ring	23508939
Compression rings	23509100 2 rings required per kit
Connecting rod upper bearing shell <sup>A</sup>	5107200
Connecting rod lower bearing shell <sup>A</sup>	5148936
Oil filter (12 µm) <sup>A</sup>	23518524 2 required

<sup>A</sup> Parts not in 23508936 cylinder kits.

8.2.4 *Service Part Kit*—Use the service parts (see [Annex A3](#)) and special parts in 8.2.5 and build-up procedures appropriate to the 6V92TA test engine stated in the service manual. Engine build-up and overhaul cannot be easily accomplished without this manual. Special service test cylinder kits (23508936) comprise parts that shall be replaced after each test and are available by order from any Detroit Diesel Distributor. These parts have undergone 100 % inspection by the test developer and orders for these uniquely numbered parts are linked by computer to a centrally controlled supply. The parts that replaced each test are included in these special service kits. They shall be used with no substitutions. Any difficulties experienced in ordering these pre-inspected parts should be referred to the test developer.<sup>8</sup>

8.2.5 *Required New Engine Parts*—See [Table 1](#).

8.2.6 *Parts Replaced As Needed*—See [Table 2](#). Not routinely replaced, these parts have normal service part numbers and shall be used.

8.2.7 *Cylinder Liners*—The following measurements and directives shall be followed for free standing cylinder liners.

8.2.7.1 Measure diametrical cylinder bore:

- 13 mm (0.5 in.) from the top
- 25 mm (1 in.) above ports
- 25 mm (1 in.) below ports
- 13 mm (0.5 in.) from bottom

Specified range is 122.911 to 122.974 mm (4.8390 to 4.8415 in.). Measure and report on two axes (eight total measurements). Use Form 11 (see [Annex A5](#)) for reporting these measurements.

8.2.7.2 *Average Surface Finish*<sup>10,11</sup>—Maintain 1.1–1.7 µm (45–65 µin.)  $R_a$  above the ports. Use Form 11 (see [Annex A5](#)) for reporting these measurements.

8.2.7.3 Sort liners by flange height, identified by *L* or *H*. Use only the same flange heights on each side of the engine; however both sizes may be used in the same engine.

<sup>10</sup> The sole source of supply of the apparatus known to the committee at this time is Taylor Hobson (Form Talysurf), available from Rank Precision Industries, 411 East Jarvis Ave., Des Plaines, IL 60018.

<sup>11</sup> If you are aware of alternative suppliers, please provide this information to ASTM International Headquarters. Your comments will receive careful consideration at a meeting of the responsible technical committee<sup>1</sup>, which you may attend.

**TABLE 2 Parts To Be Replaced as Needed**

Part Name	Part Number
Connecting rod	5104501
Fuel injector 145 mm <sup>3</sup> (6 required)	5226555 <sup>A</sup>
Turbocharger (1.23 A/F OTM MNT, 4 in. IN)	23502746
Blower	23505854
Plate oil cooler	8547237
Water pump	892236

<sup>A</sup> For rebuilt injectors see 8.2.15.

8.2.8 *Piston Ring Measurement*—Measure all rings as follows:

8.2.8.1 Measure radial thickness for all fire and compression rings. Measure in five locations, two at 25 mm each side of the ring gap, one opposite the gap, and two more locations mid-distance between the gap and opposite the gap. Average the measurements and record on Form 10 (see [Annex A5](#)).

8.2.8.2 Measure end gaps using 123.0 mm (4.840 in.) gage.<sup>11,12</sup>

(1) *Fire and Compression Rings*—1.016 ± 0.127 mm (0.040 ± 0.005 in.).

(2) *Oil Control Rings*—Upper 0.4064 ± 0.025 mm (0.016 ± 0.001 in.). Lower 0.5842 ± 0.051 mm (0.023 ± 0.002 in.).

8.2.8.3 Weigh all rings in grams. Use Form 10 (see [Annex A5](#)) for reporting these measurements.

8.2.9 *Piston Skirt Measurements and Clearances*:

8.2.9.1 Diameter of the piston shall be 122.667 to 122.733 mm (4.8294 to 4.8320 in.) measured<sup>11,13</sup> at 13 mm (0.5 in.) toward the top of the piston skirt 90° from the piston pin hole. This dimension includes tin plate.

8.2.9.2 Tin plate thickness for pistons supplied in the test kit shall be measured and verified to be in specification by the test kit supplier.

8.2.9.3 Piston skirt to liner clearance shall fall between 0.1778 and 0.3048 mm (0.007 and 0.012 in.), to be determined by subtracting diameters. Use Form 11 (see [Annex A5](#)) for reporting these measurements.

8.2.10 *Piston Pin Slipper Bushing*—Weigh to ±0.001 g. Use Form 10 (see [Annex A5](#)) for reporting these measurements.

8.2.11 *Main Bearings*—Inspect main bearing shells prior to each test and replace every three tests or sooner, if necessary.

8.2.12 *Rocker Arm Bushings Injector Position*—Measure<sup>11,14</sup> the inside diameter and record on Form 11 (see [Annex A5](#)).

8.2.13 *Valves*—Leak check prior to each test. Regrind or replace valves every five tests. See 8.4.2.2.

8.2.14 *Connecting Rods*—Install a new set of six connecting rods at least every tenth test. It is recommended that all six connecting rods be replaced following a cylinder kit failure.

<sup>12</sup> The sole source of supply of the apparatus known to the committee at this time is a Hemco Master 4.840 Class Y Ring Standard, available from Rex Supply Corporation, 8539 North East Loop 410, San Antonio, TX 78216.

<sup>13</sup> The sole source of supply of the apparatus known to the committee at this time is a Mitutoyo (4–5 in.) C Clamp micrometre #293-751-10, available from L. Dewitt McCarter, Inc., 318 East Nakoma, San Antonio, TX 78216.

<sup>14</sup> The sole source of supply of the apparatus known to the committee at this time is a Mitutoyo Inside Micrometre #568-406, available from L. Dewitt McCarter, Inc., 318 East Nakoma, San Antonio, TX 78216.

8.2.15 *Injectors*—Check injector output every test. These data may be recorded on the form in **Appendix X3**, (**Fig. X3.10**) or a similar form. Replace with new or rebuilt injectors if injector requirements are not met. These are described in Section 2.0 of the Shop Notes.<sup>9</sup> A special tool, J22410 is called for.

8.2.15.1 If injector rebuilding is selected, use the following injector exchange program, ASTM Injector Exchange Program, Detroit Diesel Remanufacturing—West, Inc., 100 Lodestone Way, Tooele, UT 84074. Attention: ASTM Injector Exchange Administrator.

8.2.16 *Ordering Information:*

8.2.16.1 Refer to Part Number 5226555 ASTM.

8.2.16.2 Delivery will be ten days after ordering.

8.2.16.3 Injectors will be identified with “ASTM” conspicuously stamped on the injector body.

8.2.16.4 It is recommended that laboratories maintain 12 working and calibrated injectors per engine minimum.

8.2.17 *Additional Information:*

8.2.17.1 Injectors will be disassembled and cleaned.

8.2.17.2 A new spray tip assembly will be installed.

8.2.17.3 Plunger and bushing to be machined to new part specifications.

8.2.17.4 Output flow specification 140 to 145 cc.

8.2.17.5 All injectors to be visually inspected for visual and functional defects.

8.3 *Special Cleaning Procedures*—Before any major disassembly, drain the engine of lubrication oil, water and fuel. Before removing any subassemblies from the engine (but after removal of the electrical equipment) thoroughly clean the exterior of the engine. Then, after each subassembly is removed and disassembled, clean the individual parts as necessary. Engine build-up forms are provided in **Appendix X3** and may be used to organize the cleaning, parts measurements, and engine build-up tasks.

8.3.1 *Engine Block Cleaning*—Complete disassembly of the block may not be required, provided adequate cleaning is accomplished. This modification shall be included in the test report. If disassembly is required, the following procedure should be used. Note that a new service replacement cylinder block shall be cleaned with Penetone<sup>11,15</sup> to remove the rust preventive and the oil galleries shall be blown out with compressed air. (**Warning**—In addition to other precautions, to prevent possible personal injury, wear adequate eye protection. Penetone is a solvent and should not be ingested, nor come into contact with eyes or more than casual contact with the skin; spray goggles and hand protection are recommended. Use an airgun meeting OSHA standards.)

8.3.1.1 If judged necessary, the engine block should be completely disassembled and cleaned thoroughly by solvent

spraying<sup>11,16</sup> with Varsol 3139.<sup>17</sup> Alternatively, the block may be soaked in Penetone for about 12 h. (**Warning**—Health hazard.)

8.3.1.2 Scrape all gasket material from the cylinder block. (**Warning**—In addition to other precautions, unless it is known otherwise, treat all gasket material in the engine and subassemblies as though it contains asbestos. When stripping gaskets from parts, do not grind or file off the material or abrade it off with a wire brush or wheel. Use a putty knife to remove the gasket after it has been wetted with water or oil.)

8.3.1.3 Before each run, all oil gallery plugs and core hole plugs (except cup plugs) should be removed to allow the cleaning solution to contact the inside of the oil and water passages. This permits more efficient cleaning. As a minimum, the engine may be solvent flushed while remaining on the test stand.

8.3.1.4 Rinse the block in hot water to remove cleaning solution.

8.3.1.5 Dry the cylinder block with compressed air. (**Warning**—In addition to other precautions, to prevent possible personal injury, wear adequate eye protection. Use an airgun that conforms to OSHA requirements.)

(I) The above procedure may be used on all ordinary cast iron and steel parts of the engine, unless specifically mentioned.

8.3.2 *Cylinder Head Cleaning*—After the cylinder head has been disassembled and all of the plugs (except cup plugs) have been removed, thoroughly solvent clean the head and dry with compressed air. Do not soak heads in Penetone because it will deteriorate the fuel injector tube seals. Instead use an aliphatic hydrocarbon to wash the heads. (**Warning**—In addition to other precautions, aliphatic hydrocarbons should not be ingested, nor come into contact with eyes or more than casual contact with the skin. Spray goggles and hand protection are recommended.)

8.3.3 *Piston Ring Cleaning*—Remove heavy carbon from the piston rings by using an ultrasonic bath with Oakite Rust Stripper<sup>11,18</sup> as a cleaning medium. A concentration of 150 g/L has been found effective. Agitate for 1 h and rinse with hot water. Rinse rings with EF-411<sup>11,19</sup> as soon as possible to prevent rusting. (**Warning**—Health hazard.) (**Warning**—In addition to other precautions, the rust stripper is caustic. Use eye and hand protection.)

8.3.4 *Air Box Cleaning*—Special attention shall be given to the airbox area to ensure that there is no residual debris that

<sup>15</sup> The sole source of supply of the apparatus known to the committee at this time is Penetone (specifically Penmul L-460), a product of Penetone Corp., P.O. Box 22006, Los Angeles, CA 90022.

<sup>16</sup> The sole source of supply of the apparatus known to the committee at this time is a Flex-Rite Spray Gun, available from Snap-On, Dan Rodgers, 114 Storywood, San Antonio, TX 78217.

<sup>17</sup> Aliphatic hydrocarbons are available at local petroleum product suppliers.

<sup>18</sup> The sole source of supply of the apparatus known to the committee at this time is Oakite Rust Stripper, OF, available from Wrico, 4835 Whirlwind, San Antonio, TX 78217.

<sup>19</sup> The sole source of supply of the apparatus known to the committee at this time is EF-411, available from Mobil Oil Corp., Att: Illinois Order Board, P.O. Box 66940, AMF-O’Hare, IL 60666. Request P/N 47503–8.

could be ingested through the liner ports in subsequent tests. A check for air flow from the air box drain tubes should be made as outlined in the service manual.

8.3.5 *Oil Heat Exchanger Cleaning*—Disassemble and flush oil side with Varsol 3139. Water side may be cleaned as necessary.

8.3.6 *Blower Cleaning*—Remove rear cover and drain all oil, then wash front and rear with Varsol or equivalent.

8.3.7 *Turbocharger Cleaning*—Do not routinely wash or clean turbocharger; just drain oil.

8.3.8 *Crankshaft*—Blow out drilled passages in the crankshaft.

8.4 *Periodic Maintenance Inspections*—Use forms equivalent to those shown in **Appendix X3**. As contrasted with the inspections and test part measurements made in **8.2**, make the following inspections only at periodic intervals based on the overhaul experience of the laboratory; not necessarily after each test. However they should be done after each failure where obvious overheating occurred.

8.4.1 *Cylinder Block Inspection*—Remove liners with the special tool described in the service manual. Do not attempt to push the liner out by inserting a bar in the liner ports and rotating the crankshaft, otherwise the piston may be damaged or the upper ring groove may collapse.

8.4.1.1 *Inspect Block Bores*—Because most of the engine cooling is accomplished by heat transfer through the cylinder liners to the water jacket, a good liner-to-block contact must exist when the engine is operating. After the cylinder liners are removed from the engine, the block bores shall be inspected as outlined in the service manual.

8.4.1.2 *Check for Flatness*—The cylinder head contact surfaces shall be checked for flatness with an accurate straight edge and a feeler gage. The cylinder head deck surfaces of the block shall not vary more than 0.003 in. (0.076 mm) transversely and not over 0.006 in. (0.152 mm) longitudinally.

8.4.1.3 *Check Counterbore Depth*—Make sure the cylinder liner counterbores in the block are clean and free of dirt. Then check the depth. They shall be either 0.4755 to 0.4770 in. (12.078 to 12.116 mm) or 0.4905 to 0.4920 in. (12.459 to 12.497 mm) and shall not vary more than 0.0015 in. (0.0381 mm) throughout the entire circumference. Tool J22273<sup>8,20</sup> or equivalent is recommended for this measurement.

8.4.1.4 *Check Main Bearing Bores*—Check the bore diameters<sup>11,21</sup> with the main bearing caps in their original positions. The specified main bearing bore diameter is 4.812 to 4.813 in. (122.225 to 122.250 mm). If the bores do not fall within these limits, the block shall be rejected. Main bearing bores are line-bored with the bearing caps in place and thus are in longitudinal alignment. If a main bearing bore is more than 0.001 in. (0.025 mm) maximum overall misalignment or 0.0005 in. (0.013 mm) misalignment between adjacent bores, the block shall be line-bored or scrapped.

<sup>20</sup> Specialized overhaul tools and a listing of such tools necessary for the overhaul of the engine used in this test method can be purchased from Detroit Diesel distributors.

<sup>21</sup> The sole source of supply of the apparatus known to the committee at this time is a Sunnen Model CF-1000 Bore Gage, available from Sunnen Products, 7910 Manchester, St. Louis, MO 63143.

8.4.1.5 The cylinder block main bearing bore measurements should be made with the block in an upside down position on a flat surface rather than on an engine overhaul stand.

8.4.1.6 *After Inspection*—If the cylinder block is not to be used immediately, spray the machined surfaces with EF-411.<sup>11,19</sup>

8.4.2 *Cylinder Head Inspection:*

8.4.2.1 It is good practice to inspect cylinder heads for cracks after each test. A number of methods are described in the service manual for this purpose. A service replacement cylinder head is available which includes the exhaust valve guides, valve seat inserts, water nozzles, injector tubes, pilot sleeves, bridge guides, valve spring seats and the necessary plugs. The head shall be rebuilt at least every five runs. If the plugs are replaced separately, coat the threads with Loctite Pipe Sealant with Teflon<sup>11,22</sup>, install the necessary plugs and tighten to torque specified in the service manual.

8.4.2.2 Leak test valves after each test. Commercial testers<sup>11,23</sup> are specifically manufactured for this purpose.

8.4.2.3 Check exhaust valve to head protrusion/recession after each test and log the results on forms equivalent to those shown in **Fig. X3.10**. If valve recession exceeds 0.711 mm (0.028 in.) replace valve seats.<sup>11,24</sup>

8.4.3 *Rocker Arm Bushing, Injector Position*—Check inside diameter of the bushing and record on Form 11 (see **Annex A5**). Replace if rocker arm shaft to bushing clearance exceeds 0.102 mm (0.0040 in.).

8.4.4 *Other Part and Sub-Assembly Inspection*—Other parts and subassemblies should be inspected less frequently, based on laboratory experience. Procedures are outlined in detail in the service manual for the inspection of all parts and subassemblies. Particular attention should be paid to making visual inspections of such items as the turbocharger aftercooler and turbine wheel assembly where deposit build-up is gradual and therefore performance deterioration is difficult to detect.

8.5 *Engine Build-up Procedures:*

8.5.1 *General*—Assembly procedures and the numerous special tools required are not detailed in the following, but should be done in accordance with the instructions in the service manual.

8.5.2 *Parts Selection*—Instructions concerning the use of new or used parts are given under **8.2**.

8.5.3 *Engine Measurement Records*—Record engine parts measurements on data sheets equivalent to those shown in **Appendix X3**. Certain critical parts measurements are also recorded in **Annex A5**.

8.5.4 *Build-up Lubrication*—Lubricate all engine parts with EF-411<sup>11,19</sup> during assembly.

<sup>22</sup> The sole source of supply of the apparatus known to the committee at this time is Loctite J26558-92, available from local distributors of Permatex products or from Permatex Company, Inc. (Loctite Corporation), 18731 Cranwood Parkway, P.O. Box 7138, Cleveland, OH 44128-7137. Trademark Teflon.

<sup>23</sup> The sole source of supply of the apparatus known to the committee at this time is a Sioux 1630K Vacuum Tester, available from Sioux Tools Inc., 2909 Floyn Boulevard, Sioux City, IA 51102.

<sup>24</sup> The sole source of supply of the apparatus known to the committee at this time is a Kwik-Way Out-of-Round Tool P/N 049-0340-24, available from Kwik-Way, 500 57th Street, Marion, IA 52302.

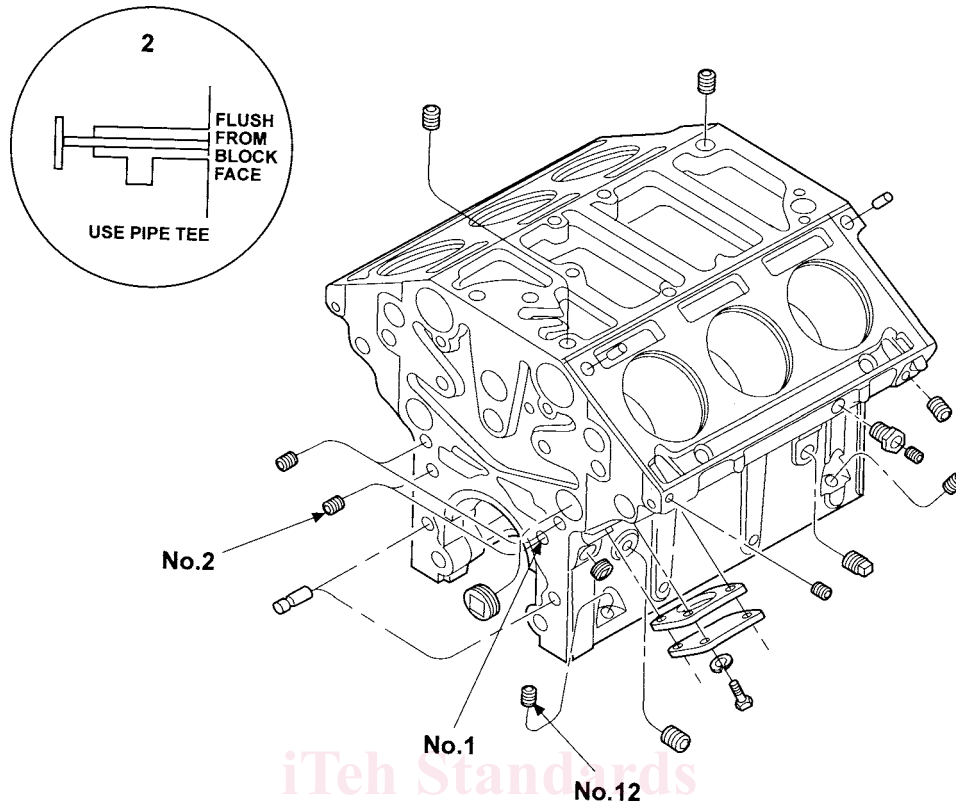

FIG. 2 Position of Pressure and Temperature Sensors

8.5.5 *Sealing Compounds*—During rebuilding, cylinder head bolts and main bearing bolts which are torqued to specific settings shall be first coated with International Compound No. 2.<sup>11,25</sup> Be sure that no excess is left on the bolts. However, all bolts, plugs, fittings or fasteners, (including studs) that intersect with a through hole and come in contact with oil, fuel or coolant shall have a sealer applied to the threads. It is recommended that Loctite J26558-92 Pipe Sealant with Teflon, or equivalent, be used. Exercise care to use International Compound No. 2 only when specified in the service manual.

8.5.6 *Gaskets and Seals*—Use new gaskets and seals as necessary at all locations during each engine assembly. Utilize gasket kit No. 23512684. The gasket between the turbocharger and blower (No. 8925778) shall be renewed each test.

8.5.7 *Engine Assembly:*

8.5.7.1 *Install Connecting Rods to Pistons*—Torque connecting rod bolts to 55–60 lbf-ft (75–81 N·m). Use International Compound No. 2 on threads when torquing.

8.5.7.2 *Install Pistons into Cylinder Liners*—With the piston assembled to the connecting rod and the piston rings in place, lubricate the piston, rings, and inside surface of the piston ring compressor J2422 as described in the service manual. Use EF-411<sup>11,19</sup> to lubricate the surfaces.

8.5.7.3 *Install Liners into Block*—Slide the piston, rod, and liner assembly into the block bore until the liner flange rests

against the insert in the counterbore in the block. Ensure that the various matchmarks described in the service manual are in line.

8.5.7.4 *Install Lower Bearing Shell*—Tighten the connecting rod bolt nuts to 60–70 lbf-ft (81–95 N·m).

8.5.7.5 *Assemble and Install Cylinder Head*—After cleaning and inspection, assemble and install the cylinder head as described in the service manual. Note that a special lifting tool is required. Note that the bolt tightening sequence described shall be followed.

8.5.7.6 *Install Subassemblies*—Complete the engine assembly by installing all remaining accessories, fuel lines, electrical connections, controls, etc.

9. Measurement Instrumentation

9.1 *Temperature Measurement*—Use iron-constantan (Type J) thermocouples or platinum resistance thermocouples for temperature measurement.<sup>11,26</sup> Other temperature sensors that give the same results may be used, provided that they are approved by the ASTM Test Monitoring Center.

9.1.1 *Thermocouple Location*—Locate the sensing tip of all thermocouples in the center of the stream of the medium involved, unless otherwise specified.

9.1.2 *Oil Gallery*—Locate thermocouple on the right front of block in turbocharger oil feed line, flush with block face. See Fig. 2, location No. 2.

<sup>25</sup> The sole source of supply of the apparatus known to the committee at this time is International Compound No. 2, available from IRMCO, 2117 Greenleaf Street, Evanston, IL 60202.

<sup>26</sup> Thermocouples and packing glands (Part MPG-125-A-T) have been found suitable and are available from the Sales Department of Conax Corporation, 2300 Walden Ave., Buffalo, NY 14225.



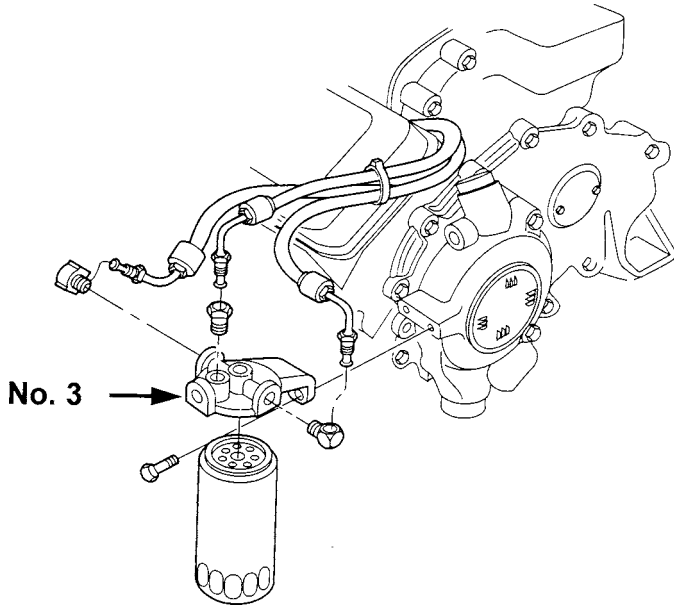

FIG. 3 Position of Pressure and Temperature Sensors

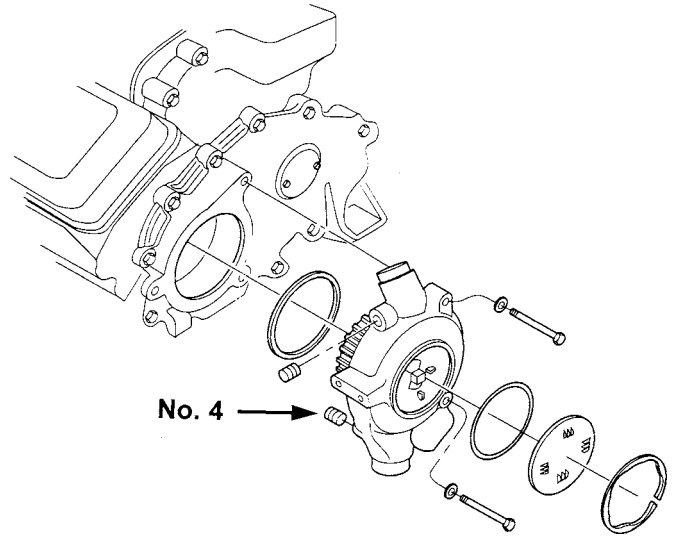

FIG. 3 (continued)

9.1.3 *Fuel In*—Locate thermocouple at the fuel filter. See Fig. 3, location No. 3.

9.1.4 *Coolant In*—Locate thermocouple at coolant inlet to coolant pump. See Fig. 3, location No. 4.

9.1.5 *Coolant Out*—Locate thermocouple after right and left thermostat housing outlets join. See Fig. 4, location No. 5.

9.1.6 *Air Inlet*—Locate thermocouple before compressor. See Fig. 1, location No. 7.

9.1.7 *Air Box*—Locate thermocouple right bank, rear air box cover. Tip of thermocouple should be 32 mm (1¼ in.) inside air box cover.

9.1.8 *Oil Sump*—Locate thermocouple in left side of oil sump, 50 to 120 mm (2 to 5 in.) from back and 50 to 100 mm (2 to 4 in.) from bottom of oil pan. See Fig. 5, location No. 11.

9.1.9 *Exhaust*—Locate thermocouple as shown in Fig. 1, location No. 13.

9.2 *Pressure Measurement*—Use pressure sensors such as pressure gages or manometers, or electronic transducers, located as indicated, and following the established guidelines.<sup>27</sup>

9.2.1 *Pressure Sensor Location*—Locate pressure sensors in the center of flow unless otherwise specified.

9.2.2 *Oil Gallery*—Locate pressure sensor on the left front of block. See Fig. 2, location No. 1.

9.2.3 *Air Inlet*—The air inlet restriction sensor (4-hole piezometer) is located in the air inlet, 150 ± 25 mm (6 ± 1 in.) from turbocharger as shown in Fig. 1, location No. 6.

9.2.4 *Exhaust Back Pressure*—Locate 4-hole piezometer in exhaust stream as shown in Fig. 1, location No. 8.

9.2.5 *Air Box*—Locate sensor in right bank, rear air box cover.

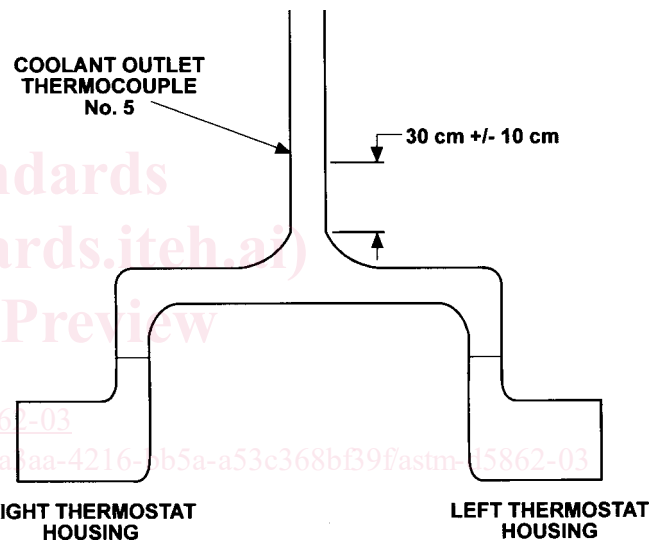

FIG. 4 Coolant Outlet Thermocouple Location

9.2.6 *Crankcase Pressure*—The sensor may be located in the front dipstick hole on the left side of the engine as shown in Fig. 2, location No. 12. This measurement is optional.

## 10. Reagents and Materials

10.1 *Test Fuel*—Use ASTM 2D Fuel or equivalent. It shall have the specific properties shown in Annex A4 (Table A4.1). (**Warning**—Combustible. Health hazard.)

10.1.1 Make certain that all tanks used for transportation and storage are clean before they are filled with test fuel.

10.1.2 Verify that at least 11 300 L (3000 gal) of test fuel is available before starting the test.

### 10.2 Test Oil:

10.2.1 *Selection*—The supplier of the test oil sample shall determine that it is representative of the lubricant formulation being evaluated and that it is not contaminated.

10.2.2 *Quantity*—The supplier of the test oil shall provide approximately 100 L (25 gal) of the test oil sample.

<sup>27</sup> Supporting data (1987-04-02 Instrumentation Task Force Report to the ASTM Committee D02.B0.08 Technical Guidance Committee) have been filed at ASTM International Headquarters and may be obtained by requesting Research Report RR: D02-1218.

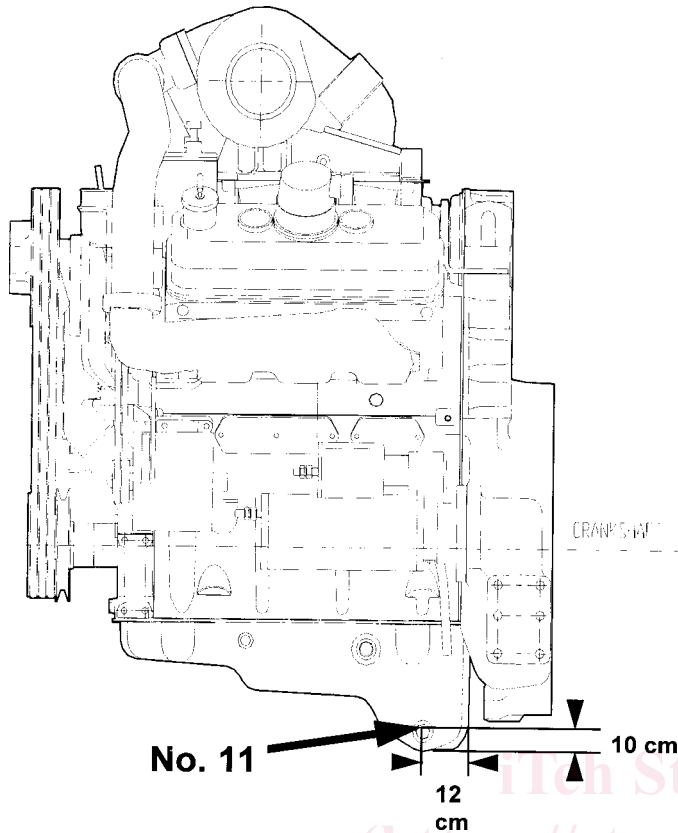

FIG. 5 Oil Sump Temperature Sensor Location

10.2.3 *Identification*—The oil sample shall be clearly identified with the name of the test sponsor, the oil formulation, and the batch code. The code number from the container is to be entered on the test report.

10.2.4 *Storage Prior to Test*—The test laboratory shall store the test oil sample in a covered building to prevent both contamination by rainwater and excessive heat exposure.

10.3 *Coolant Composition*—A 50 % concentration of regular grade ethylene glycol type antifreeze<sup>11,28</sup> in distilled water is to be used. (**Warning**—Combustible. Health hazard.)

10.4 *Sealing and Anti-seize Compounds*—The following sealing and anti-seize compounds are required for this test method:

10.4.1 *For All Bolts Under Specified Torque*—Use International Compound No. 2 to achieve proper fastener torque. Use minimum quantities and remove all excess, as discussed in 8.5.5.

10.4.2 All bolts, plugs, fittings or fasteners, (including studs) that intersect with a through hole and come in contact with oil, fuel or coolant shall have a sealer applied to the threads. It is recommended that Loctite J26558-92 Pipe Sealant with Teflon® be used, as discussed in 8.5.5.

10.5 *Cleaning Materials*—The following cleaning materials are required in the procedure. The use of alternative materials requires approval by the ASTM TMC.

10.5.1 *For Block Cleaning*—Use Penetone (specifically Penmul L-460), as discussed in 8.3.1.

10.5.2 *For Head Cleaning*—Use an aliphatic carbon, as discussed in 8.3.2.

10.5.3 *For Piston Ring Cleaning*—Use Oakite Rust Stripper OF, as discussed in 8.3.3.

10.5.4 *For Coolant System Cleaning*—Use Nalprep 2001,<sup>11,29</sup> as discussed in 13.1.2.

## 11. Hazards

11.1 *General*—The environment involved with any engine test is inherently hazardous. Serious injury of personnel and damage to facilities can occur if adequate safety precautions are not taken. However, as evidenced by the fact that many thousands of engine tests are successfully conducted each year it is possible to take adequate precautions.

11.2 *Caveat*—The following paragraphs do not cover all possible safety-related problems associated with 6V92TA testing.

11.3 *Personnel*—Carefully select and train personnel who will be responsible for the design, installation, and operation of 6V92TA test stands. Make certain that the test operators are capable of handling the tools and facilities involved and in observing all safety precautions, including avoiding contact with either moving or hot test parts.

11.4 *Personnel Protection Facilities*—Provide the following personnel protection facilities:

11.4.1 Provide safety shower and eye-rinse equipment in close proximity to the facilities used for parts cleaning, engine assembly, engine test operation, and parts rating.

11.4.2 Provide, and require the use of, appropriate face masks, eye protection, chemical breathers, gloves, and so forth, in all aspects of 6V92TA testing.

11.4.3 Provide dry chemical fire extinguishers for putting out fires.

11.4.4 Advise personnel not to use water to attempt to extinguish fires involving fuel, oil, or glycol.

11.4.5 Equip test stands with automatic fire extinguishing equipment.

11.4.6 Install suitable guards around all external moving parts, or hot parts.

11.4.7 Advise personnel not to work alongside the engine and coupling shaft when the engine is operating at high speeds.

11.4.8 Provide barrier protection between the engine and coupling shaft, and operating personnel.

11.4.9 Prohibit the wearing of loose or flowing clothing by personnel working near a running engine.

11.5 *Safety Equipment and Practices*—Observe the following in order to establish and maintain safe working conditions for 6V92TA testing:

11.5.1 Provide the proper tools for conducting the 6V92TA test.

11.5.2 Require regular inspection and approval by the laboratory safety department of the facilities used for 6V92TA testing.

<sup>28</sup> The sole source of supply of the apparatus known to the committee at this time is ethylene glycol, available locally or from Dow Chemical Company, 2040 Dow Center, Midland, MI 48674.

<sup>29</sup> The sole source of supply of the apparatus known to the committee at this time is Nalprep 2001, available from Detroit Diesel Corporation, Part Number 23507863, or Penn Ray Companies, Inc., 1801 Estes Ave., Elk Grove Village, IL 60007.

11.5.3 Properly install all fuel lines, oil lines, and electrical wiring. Maintain them in good condition.

11.5.4 Select and install coolant hoses and clamps with special care in order to prevent coolant leaks and possible fires.

11.5.5 Do not permit tripping hazards to exist in any of the areas involved with 6V92TA testing.

11.5.6 Keep the outer surfaces of the engine, other equipment, and the floor area free from fuel and oil.

11.5.7 Do not allow the accumulation of containers of oil or fuel in 6V92TA areas.

11.5.8 Demand that personnel be alert for leaking fuel, exhaust gas, oil, or coolant, and that they take action to stop such leaks.

11.5.9 Equip the test stand with an automatic fuel shutoff valve designed to turn off the fuel supply to the engine whenever the engine is not running.

11.5.10 Make provision for manual, remote operation of the fuel shutoff valve.

11.5.11 Install suitable interlocks to shut down the engine when any of the following develop: loss of dynamometer field current, engine overspeeding, loss of engine oil pressure, failure of the exhaust system, failure of the room ventilation, activation of the fire protection system, excessive vibration, and so forth.

## 12. Laboratory and Test Stand Calibration

12.1 *Frequency of Calibration*—To maintain test precision and avoid bias, engine test stand calibration is required at regular intervals. The frequency of calibration is dependent on the laboratories' previous calibration experience or at the discretion of the ASTM Test Monitoring Center. See 12.5.1.

12.2 *Reference Oils*—The reference oils used to calibrate 6V92TA test stands have been formulated or selected to represent specific chemical types or performance levels, or both. They are available from the TMC.<sup>2</sup> The Test Monitoring Center will assign reference oils for calibration tests. These oils are supplied under code numbers (blind reference oils).

12.2.1 Reference oils and subsequent reblends that have been used in this test method are:

TMC 861 (REO 217), SAE 15W-40  
TMC 862, SAE 30

12.3 *Test Numbering*—Each 6V92TA test shall be numbered to identify the test stand number, the test stand run number, engine number and number of runs made on engine. See 15.1 for test numbering protocol.

### 12.4 *New Laboratories and New Test Stands:*

12.4.1 A new stand is defined as a test dynamometer/cell and support hardware that has never been previously calibrated under this test procedure. On both new and existing stands the test engine is not part of the stand calibration.

12.4.2 A new laboratory shall have consecutive calibration test passes to be considered calibrated.

12.4.3 A laboratory not running a 6V92TA test for twelve months from the start of the last test is considered a new laboratory. Under special circumstances (that is, extended downtime due to industry-wide parts shortage or fuel outages) the TMC may extend the lapsed time requirement. Non-

reference oil tests conducted during an extended time allowance shall be annotated on Form 15 (see Annex A5).

12.4.4 The TMC may schedule more frequent reference oil tests at their discretion.

### 12.5 *Calibrated Laboratories and Test Stands:*

12.5.1 A calibration test on a reference oil assigned by the TMC is required after no more than ten operationally valid non-reference oil tests starts or after six months from the start date of the last acceptable calibration test (whichever comes first).

### 12.6 *Calibration Test Acceptance Bands:*

12.6.1 Calibration test targets and acceptance bands are published every six months by the TMC. These acceptance bands, based on a 90 % confidence level, are calculated using reference oil tests completed during the previous six-month period or ten tests, whichever is greater. Calibration status of a test laboratory is based upon the calibration test acceptance bands in effect at the time of completion of the calibration test.

12.6.2 The specified test parameters for determination of the test acceptance bands are:

12.6.2.1 Cylinder liner, % area scuffing,

12.6.2.2 Fire ring face distress, demerits, and

12.6.2.3 Second and third ring average ring face distress, demerits.

### 12.7 *Failing Calibration Tests:*

12.7.1 Failure of a reference oil test to meet test acceptance bands can be indicative of a false alarm, testing stand, testing laboratory, or industry-related problem. When this occurs, the laboratory, in conjunction with the TMC, shall attempt to determine the problem source.

12.7.2 The TMC will decide, with input as needed from industry expertise (testing laboratories, test developer, ASTM Technical Guidance Committee, Surveillance Panel, and so forth), if the reason for any unacceptable blind reference oil test is isolated to one particular stand or related to other stands. If it is decided that the problem is isolated to an individual stand, calibrated testing on other stands can continue throughout the laboratory. Alternatively, if it is decided that more than one stand may be involved, the involved stands will not be considered calibrated until the problem is identified, corrected and an acceptable reference oil test completed in one of the involved stands.

12.7.3 If non-standard tests are conducted on the calibrated test stand, the stand may be required to be re-calibrated prior to running standard tests, at the discretion of the TMC.

### 12.8 *Non-reference Oil Test Result Severity Adjustment:*

12.8.1 Fixed non-reference oil test pass criteria are published in Specification D 4485. Provision is made in this test procedure to adjust non-reference oil test results to compensate for test severity deviations from the original severity levels. Non-reference test adjustment factors represent the shift in the means of average liner scuffing, fire ring distress, and 2nd and 3rd ring face distress of Reference Oil 862 (and subsequent reblends) and are based on a moving average of the five most recent operationally valid tests on that oil.

12.8.2 Adjustment factors for non-reference tests are published semiannually by the TMC. Adjustment factors are applied (added) to individual test results based on the time