

INTERNATIONAL
STANDARD

ISO
11786

First edition
1995-06-01

**Agricultural tractors and machinery —
Tractor-mounted sensor interface —
Specifications**

iTeh STANDARD PREVIEW

(Standard iTehtai)
Tracteurs et matériels agricoles — Interface des capteurs montés sur le tracteur — Spécifications

ISO 11786:1995

<https://standards.iteh.ai/catalog/standards/sist/da0c5c22-d6f8-472b-83ff-f80b4a463ac5/iso-11786-1995>

INTERNATIONAL

ISO



Reference number
ISO 11786:1995(E)

Foreword

ISO (the International Organization for Standardization) is a worldwide federation of national standards bodies (ISO member bodies). The work of preparing International Standards is normally carried out through ISO technical committees. Each member body interested in a subject for which a technical committee has been established has the right to be represented on that committee. International organizations, governmental and non-governmental, in liaison with ISO, also take part in the work. ISO collaborates closely with the International Electrotechnical Commission (IEC) on all matters of electrotechnical standardization.

Draft International Standards adopted by the technical committees are circulated to the member bodies for voting. Publication as an International Standard requires approval by at least 75 % of the member bodies casting a vote.

International Standard ISO 11786 was prepared by Technical Committee ISO/TC 23, *Tractors and machinery for agriculture and forestry*, Subcommittee SC 19, *Agricultural electronics*.

iteh STANDARD PREVIEW
(standards.iteh.ai)
ISO 11786:1995
<https://standards.iteh.ai/catalog/standards/sist/da0c5c22-d6f8-472b-83ff-f80b4a463ac5/iso-11786-1995>

© ISO 1995

All rights reserved. Unless otherwise specified, no part of this publication may be reproduced or utilized in any form or by any means, electronic or mechanical, including photocopying and microfilm, without permission in writing from the publisher.

International Organization for Standardization
Case Postale 56 • CH-1211 Genève 20 • Switzerland

Printed in Switzerland

Agricultural tractors and machinery — Tractor-mounted sensor interface — Specifications

1 Scope

This International Standard specifies an electrical connector and its pin layout for mounting on an agricultural tractor with a nominal 12-volt battery supply for the purpose of providing an interface between tractor-mounted sensors and equipment requiring signals from those sensors. The connector also provides access to a low-current power source, to provide power primarily to instrumentation.

This International Standard therefore provides a short-term solution to data communication between a restricted set of tractor-mounted sensors and other equipment such as monitors, actuators and control systems on agricultural tractors and attached machinery, in anticipation of the availability of a standardized digital data bus system.

It allows limited data communication facilities for lower specification tractors not fitted with a digital data bus system.

2 Normative references

The following standards contain provisions which, through reference in this text, constitute provisions of this International Standard. At the time of publication, the editions indicated were valid. All standards are subject to revision, and parties to agreements based on this International Standard are encouraged to investigate the possibility of applying the most recent editions of the standards indicated below. Members of IEC and ISO maintain registers of currently valid International Standards.

DIN 405-1:1975, *Knuckle thread: profiles, basic sizes, general plan.*

DIN 405-2:1981, *Knuckle thread: deviations and tolerances.*

3 Definitions

For the purposes of this International Standard, the following definitions apply.

3.1 ground speed signal: Actual forward speed of the tractor.

3.2 theoretical ground speed signal: Product of tractor drive wheel rotational speed and the rolling wheel circumference.

NOTE 1 This is the true ground speed where there is no wheel slip. The rolling circumference is defined in ISO 11795, *Agricultural tractor drive wheel tyres — Methods of measuring tyre rolling circumference.*

3.3 linkage position signal: Position of the tractor three-point linkage in the vertical plane between its lowest and highest points.

3.4 in-work/out-of-work signal: Binary status signal indicating that the three-point linkage is situated below (in-work) or above (out-of-work) an adjustable switching threshold.

3.5 CMOS: Complementary Metal-Oxide Semiconductor.

4 Connector

4.1 Dimensions

The connector shall have the dimensions shown in figure 1.

4.2 Pin allocation

A seven-pin female bulkhead connector shall be mounted on the tractor with the following pin allocation:

- Pin 1: true ground speed
- Pin 2: theoretical ground speed
- Pin 3: rear PTO rotational speed
- Pin 4: rear three-point implement in-work/out-of-work
- Pin 5: rear three-point linkage position

— Pin 6: power supply

— Pin 7: common ground

Tractor designers may, at their discretion, connect any or none of the pins to the appropriate sources. The pin allocation shall not be changed.

4.3 Specification of connector

4.3.1 The female bulkhead connector shall contain seven pins in a polarized shell in accordance with figure 1. Pins 6 and 7 shall have a minimum current-carrying capacity of 5A.

Dimensions in millimetres

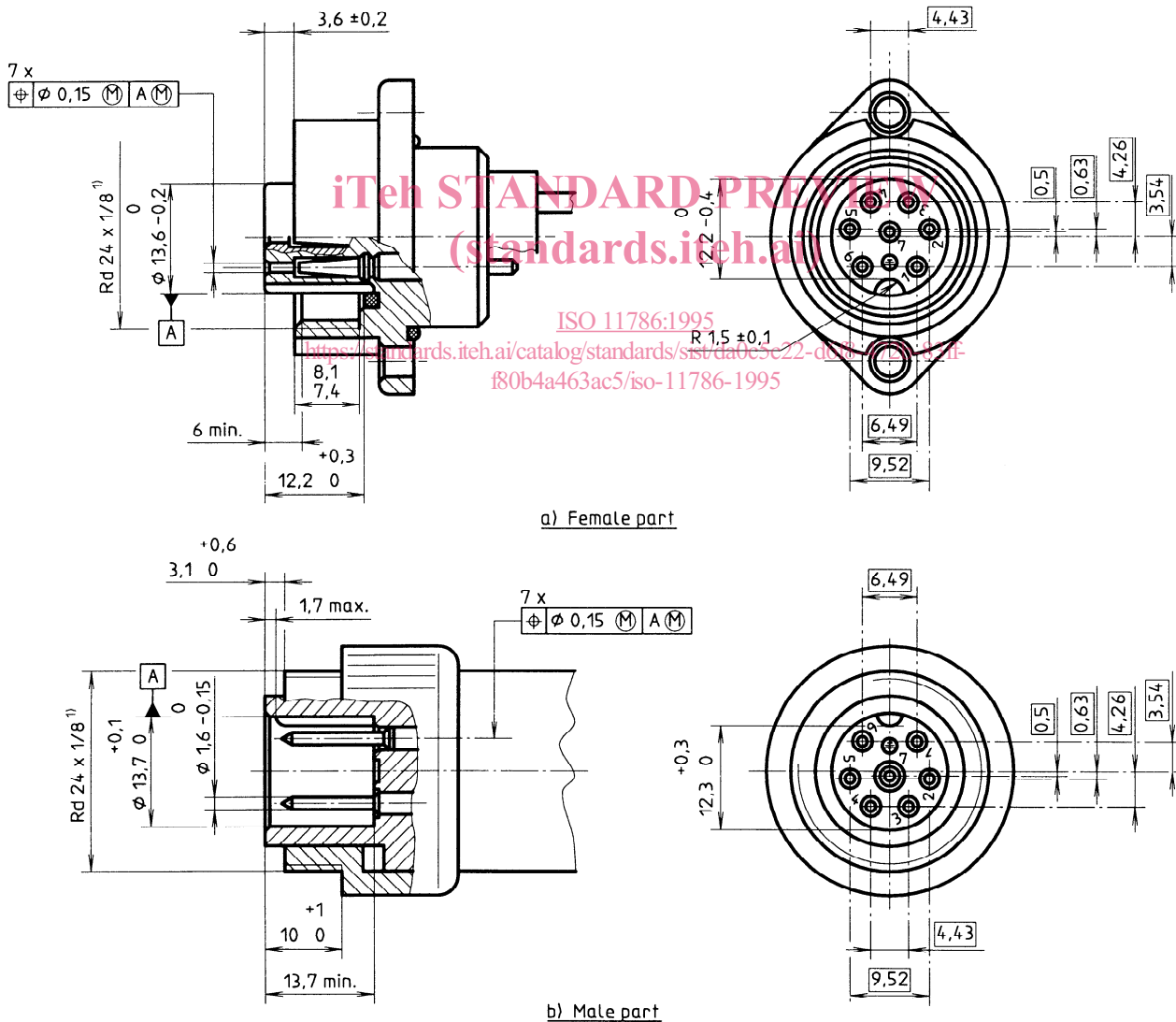

Figure 1 — Seven-pin connector dimensions

The pins shall be plated to minimize contact resistance.

The connector shall withstand a minimum of 400 connect/disconnect cycles without deterioration in performance.

4.3.2 As the position of the connection is not specified in this International Standard, environmental proofing is not specified. It is recommended that designers give consideration to the following connector features:

- moisture sealing,
- closures for when connector is not in use,
- locking rings,
- breakaway.

NOTE 2 The physical connector specification is met by the Amphenol C16-1 connector.

Amphenol is a trade-name. This information is given for the convenience of users of this International Standard and does not constitute an endorsement by ISO of the product named. Equivalent products may be used if they can be shown to lead to the same results.

4.4 Location of connector

The connector shall be located within the tractor cab.

The designer shall give due consideration to the location when determining environmental proofing of the connector. Additional, environmentally proofed seven-pin female connectors may be mounted outside the tractor cab.

5 Data signals

5.1 Signal characteristics

The signal characteristics for true and theoretical ground speed, PTO rotational speed and linkage are so specified as to be compatible with CMOS logic as

defined in JEDEC¹⁾, powered from the tractor battery with a minimum voltage of 10 V.

5.2 True ground speed and theoretical ground speed

5.2.1 The signal shall be a square wave with a duty cycle between 20 % and 80 %, and with rise and fall times less than 1 ms.

5.2.2 The signal level of the square wave "mark" (high) shall be greater than 6,3 V and the "space" (low) shall be less than 1,5 V. The output source impedance at "space" (low) shall be $100 \Omega \pm 10 \Omega$. The load impedance shall be greater than 3 k Ω .

5.2.3 At speeds greater than 1 km/h, the speed shall be represented by 130 pulses/m $\pm 5 \%$ (130 Hz/m/s $\pm 5 \%$) in a standard calibration test.

5.3 PTO rotational speed

5.3.1 The signal shall be a square wave with a duty cycle between 20 % and 80 %, and with rise and fall times less than 1 ms.

5.3.2 The signal level of the square wave "mark" (high) shall be greater than 6,3 V and the "space" (low) shall be less than 1,5 V. The output source impedance at "space" (low) shall be $100 \Omega \pm 10 \Omega$. The load impedance shall be greater than 3 k Ω .

5.3.3 At rotational speeds greater than 2 r/s, the speed shall be represented by 6 pulses per revolution (6 Hz/r/s).

5.4 In-work/out-of-work

The in-work signal shall be represented by a voltage less than 1,5 V and the out-of-work signal by a voltage greater than 6,3 V. The output source impedance at the in-work position shall be $100 \Omega \pm 10 \Omega$. The load impedance shall be greater than 3 k Ω .

NOTE 3 Leading and trailing edges of the linkage up/down signal may be corrupted by switch bounce.

1) Joint Electron Devices Engineering Council of the Electronic Industries Association, U.S.A.: Standard 13B, *Standard specifications for description of B-series CMOS devices*.

5.5 Linkage position

The signal voltage varies linearly corresponding to the height of the linkage position. The signal shall be 0 V representing the lowest position and 10 V representing the highest position. The load impedance shall be greater than 3 k Ω .

6 Power supply

Power shall be supplied to pin 6 from the tractor battery via the ignition switch.

The maximum current drawn from pin 6 shall be 5 A.

The supply shall be fused at 10 A.

iTeh STANDARD PREVIEW
(standards.iteh.ai)

ISO 11786:1995

<https://standards.iteh.ai/catalog/standards/sist/da0c5c22-d6f8-472b-83ff-f80b4a463ac5/iso-11786-1995>

iTeh STANDARD PREVIEW

This page intentionally left blank
(standards.iteh.ai)

ISO 11786:1995

<https://standards.iteh.ai/catalog/standards/sist/da0c5c22-d6f8-472b-83ff-f80b4a463ac5/iso-11786-1995>

iTeh STANDARD PREVIEW
(standards.iteh.ai)

ISO 11786:1995

<https://standards.iteh.ai/catalog/standards/sist/da0c5c22-d6f8-472b-83ff-f80b4a463ac5/iso-11786-1995>

ICS 65.020.10

Descriptors: agricultural machinery, agricultural tractors, sensors, signals, signal transmission, electric connectors, multi-contact connectors, specifications, interfaces.

Price based on 4 pages
