



Designation: A 74 – 04

Endorsed by the  
Cast Iron Soil Pipe Institute  
American Association State  
Highway and Transportation Officials Standard  
AASHTO No.: M 263-77

# Standard Specification for Cast Iron Soil Pipe and Fittings<sup>1</sup>

This standard is issued under the fixed designation A 74; the number immediately following the designation indicates the year of original adoption or, in the case of revision, the year of last revision. A number in parentheses indicates the year of last reapproval. A superscript epsilon (ε) indicates an editorial change since the last revision or reapproval.

*This standard has been approved for use by agencies of the Department of Defense.*

## 1. Scope

1.1 This specification covers cast iron soil pipe and fittings for use in gravity flow plumbing, drain, waste and vent sanitary and storm water applications. It establishes standards covering material, manufacture, mechanical and chemical properties, coating, test methods, inspection, certification, product markings, dimensions, and dimensional tolerances for extra heavy and service cast iron soil pipe and fittings. These pipe and fittings are not intended for pressure applications as the selection of the proper size for sanitary drain, waste, vent, and storm drain systems allows free air space for gravity drainage.

1.2 This specification covers pipe and fittings of the following patterns and, when so designated, shall apply to any other patterns that conform with the applicable requirements given herein.

### 1.2.1 Pipe:

Extra heavy, 2½ ft (0.75 m), 3½ ft (1.0 m), 5 ft (1.5 m), 10 ft (3.0 m) lengths	Tables 1, 2
Service, 2½ ft (0.75 m), 3½ ft (1.0 m), 5 ft (1.5 m), 10 ft (3.0 m)	1, 2
Outside dimensions (for detailing)	X1.1

### 1.2.2 Fittings:

¼ bends; long ¼ bends	Tables 3, 4
¼ bends, long low-hub	5
¼ bends, low heel; high heel	6, 7
¼ bends, short sweep; long sweep	8
¼ bends, reducing long sweep	9
⅓ bends	10
½ bends	10
⅝ bends; long ⅝ bends	11
⅞ bends	11
Y branches	12, 13
Y branches, cleanout on main	14
Y branches, cleanout on branch	15
Y branches, inverted	16

Y branches, combination ⅓ bends, single	17
Y branches, combination ⅓ bends, double	17
Y branches, combination ⅓ bends, cleanout	18
Y branches, upright	19
Sanitary T branches, single	20
Sanitary T branches, double	20
Sanitary T branches, cleanout	21
Tapped sanitary T branches, single	22
Tapped sanitary T branches, double	22
T branches, single and double	23
Tapped T branches, single	24
Tapped T branches, double	24
Horizontal twin tapped T	25
T branches, cleanout	26
Vent branches, single	27
Offsets, ⅓ bend	28
Double hubs	29
Long double hubs	29
Reducers	30
Increases	31, 32
S traps	33
P traps	34, 35
Deep seal P traps	36
Running traps	37
Screw plugs (brass)	38
Blind plugs	39
Iron-body ferrules	40
Side inlets	Fig. 3
Closet bends	41
Tapping bosses	42
Hubbed Cleanout Cap	43

1.3 The values stated in inch-pound units are to be regarded as the standard. The values given in parentheses are for information only. Metric conversions in Table 1 and Table 2 are to two decimal places; all other metric conversions are rounded to the nearest whole number.

## 2. Referenced Documents

### 2.1 ASTM Standards:<sup>2</sup>

- A 48 Specification for Gray Iron Castings
- A 644 Terminology Relating to Iron Castings
- E 8 Test Methods for Tension Testing of Metallic Materials

<sup>1</sup> This specification is under the jurisdiction of ASTM Committee A04 on Iron Castings and is the direct responsibility of Subcommittee A04.12 on Pipes and Tubes.

Current edition approved Jan. 1, 2004. Published February 2004. Originally approved in 1917. Last previous edition approved in 2003 as A 74 – 03b.

<sup>2</sup> For referenced ASTM standards, visit the ASTM website, www.astm.org, or contact ASTM Customer Service at service@astm.org. For *Annual Book of ASTM Standards* volume information, refer to the standard's Document Summary page on the ASTM website.

## 2.2 Federal Standard:

Fed. Std. No. 123 Marking for Shipment (Civil Agencies)<sup>3</sup>

## 2.3 Military Standard:

MIL-STD-129 Marking for Shipment and Storage<sup>3</sup>

## 2.4 ANSI/ASME Standard:

B2.1 Pipe Threads<sup>4</sup>

### 3. Terminology

#### 3.1 Definitions of Terms Specific to This Standard:

3.2 *Manufacturer, n*—the entity that casts the pipe and fittings covered by this standard.

### 4. Materials and Manufacture

4.1 The pipe and fittings shall be iron castings suitable for installation and service for sanitary, storm drain, waste, and vent piping applications. The pipe and fittings shall meet all applicable requirements and tests given herein.

4.2 The castings shall be made of cast iron, produced by an established commercial method that provides control over chemical and physical properties. Cast iron is a generic term for a series of alloys as defined in Terminology A 644 and includes gray iron as well as ductile iron. The castings shall be sound, true to pattern, and of compact close grain that permits drilling and cutting by ordinary methods. The interior surface shall be reasonably smooth and free from defects which would make the castings unfit for the use for which they are intended.

4.3 To minimize the possibility of introducing radioactive material to a melting operation, ferrous scrap and pig iron shall be screened for radioactivity with suitable detection devices operated in accordance with the detection manufacturer's instructions. Records shall be maintained by load of these tests for a period of seven years.

4.4 Material, which is found contaminated with radioactivity, shall not be used to produce products covered by this standard.

4.5 Analysis of castings, after the time of production shall not be used to determine compliance to this standard.

### 5. Mechanical Properties

5.1 *Mechanical Tests for Gray Iron*—The manufacturer shall perform tests to determine mechanical properties of the gray iron used in the manufacture of gray iron soil pipe and fittings. Tension test specimens shall be employed. The manufacturer shall maintain a record of Mechanical test for a minimum of 7 years.

5.1.1 *Tensile Strength Test*—The tensile strength shall be not less than 21 000 psi (145 MPa).

5.1.2 Analysis of castings or test bars, after the time of production shall not be used as evidence of compliance to this standard.

### 6. Chemical Test for Gray Iron

6.1 The manufacturer shall perform tests to determine the significant chemical constituents of the gray iron used in the manufacture of gray iron soil pipe and fittings. Analysis shall

be performed at the minimum of once per lot as defined in this standard. The manufacturer shall maintain a record of chemical tests performed for a minimum of 7 years. The test results shall conform to the following requirements as to chemical composition:

Phosphorous (P)	0.38 % Maximum
Sulfur (S)	0.15 % Maximum
Chromium (Cr)	0.50 % Maximum
Titanium (Ti)	0.10 % Maximum
Aluminum (Al)	0.50 % Maximum
Lead (Pb)	0.015 % Maximum
Carbon Equivalent	4.10 % Minimum by mass
Note: Carbon equivalent for gray iron = %C+%Si/3+%P/3	

6.1.1 Chemical tests shall be performed at the time of production of the castings covered by this standard.

6.1.2 Analysis of castings after the time of production shall not be used as evidence of compliance to this standard.

### 7. Dimensions and Permissible Variations

#### 7.1 Pipe:

7.1.1 Single-hub pipe shall have a hub at one end and a spigot at the other. Double hub pipe shall have a hub at each end. Hubs shall have lead grooves. The inner end of hub shall be either with or without a centering recess, all combinations of which shall make a satisfactory leakproof joint. Hub and barrel shall be cast in one piece (see Fig. 1).

7.1.2 Single-hub pipe shall be of 2½-ft (0.75-m), 3½-ft (1.00-m), 5-ft (1.5-m), and 10-ft (3.0-m) nominal laying lengths. The laying length shall be as shown in Table 1 and shall be within the tolerances on laying length specified in Table 2. Double-hub pipe shall be of the same overall length as single-hub pipe of the same size. Its laying length shall be 5 ft minus the two telescoping lengths (dimension Y), or 10 ft minus the telescoping length (dimension Y). Other dimensions shall be as specified in Table 1 as applicable, and be within the tolerances specified in Table 2. The dimensions shall apply to pipe before any coating is applied.

7.1.3 Pipe shall be straight to the extent that any deflections in the barrel of a 2½-ft (0.75-m), 3½-ft (1.00-m), and 5-ft length of pipe shall not exceed ¼ in. (6.4 mm) for sizes 4 in. (102 mm) and larger, and shall not exceed ⅝ in. (7.9 mm) for smaller sizes; for 10-ft lengths, deflections in the barrel shall not exceed ½ in. (12.7 mm) for sizes 4 in. and larger, nor exceed ⅝ in. (15.9 mm) for smaller sizes.

#### 7.2 Fittings:

7.2.1 *Dimensions of Fittings*—All fittings shall conform to the dimensions specified for hub and spigot ends in Table 1 and Table 2, as applicable. Fittings of the patterns specified herein shall conform to the applicable dimensions in Tables 3-34 inclusive, and to the tolerances in Table 2. Other patterns (Note 1) shall conform to Table 1, as applicable, for hub and spigot dimensions, and for wall thickness throughout, and to dimension R', Tables 15-17, for the minimum radius of any drainage inlets that such fittings shall be permitted to provide. All fittings shall have spigot ends of sufficient length to provide adequate room for making joints. All dimensions given herein shall apply to fittings before any coating is applied.

NOTE 1—Such as, for example, fittings known in the trade as "specials," when designated as being in conformity with this specification.

<sup>3</sup> Available from Standardization Documents Order Desk, Bldg. 4 Section D, 700 Robbins Ave., Philadelphia, PA 19111-5094, Attn: NPODS.

<sup>4</sup> Available from American National Standards Institute (ANSI), 25 W. 43rd St., 4th Floor, New York, NY 10036.

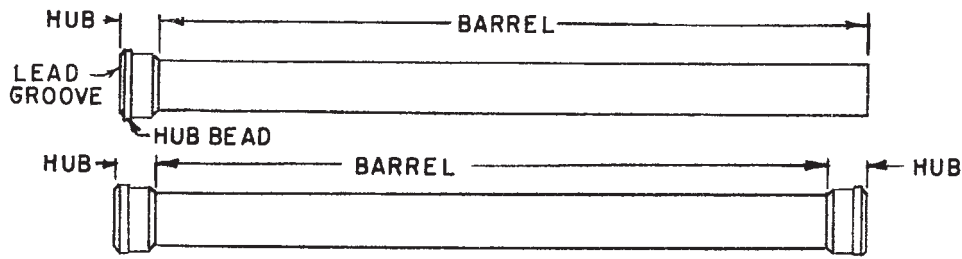

FIG. 1 Single-Hub and Double-Hub Cast Iron Soil Pipe Laying Lengths

7.2.2 *Water Seal and Traps*—Traps shall have water seals as follows:

Trap Size, in. (mm)	Minimum Water seal, in. (mm)
2 (50)	2 (50)
3 to 6 (75 to 150), incl	2½ (64)
8 to 12 (200 to 300), incl	3 (75)

7.2.3 *Ends of Fittings*—Hubs shall have lead grooves. The inner end of hub shall be permitted to be either with or without a centering recess, all combinations of which shall enable the installer to make a satisfactory joint. Tapped openings shall conform to 7.2.4. It is permissible to increase the wall thickness on the inside surface of fittings having one or more plain ends. The increased thickness shall not reduce the minimum *B* dimension in Table 1 in excess of 0.10 in. for sizes 8 in. and smaller, and 0.15 in. for 10 in. and larger, and shall not extend more than 4 ¼ in. from the plain end. The increased thickness shall be tapered and offer no obstruction to flow. Inside diameters complying with service or extra heavy inside diameters shall be permitted on 12 and 15 in. sizes only.

7.2.4 *Pipe Threads*—Screw plugs and tapped openings in fittings shall have American Standard taper pipe threads. The threads shall be in accordance with ANSI/ASME B 2.1 of the current issue.

7.2.5 *Internal threads* shall be chamfered on the entering end approximately to the major diameter of the thread, at an angle of approximately 45° with the axis of the thread, and the entering end of external threads shall be similarly chamfered approximately to be minor diameter of the thread, for easy entrance in making a joint and for protection of the thread. The chamfer shall be concentric with the thread and shall be included in measurements of thread length.

## 8. Methods of Specifying Fittings

8.1 *Method of Specifying Sizes of Fittings of More than One Size*—The sizes are designated by the order of listing, as follows:

- 8.1.1 Branch and tapped fittings:
  - 8.1.1.1 Size of run (Note 2), and
  - 8.1.1.2 Size of branch.
- 8.1.2 Reducers, increasers, and offset fittings:
  - 8.1.2.1 Size of inlet or run (Note 2),
  - 8.1.2.2 Size of outlet or offset distance,
  - 8.1.2.3 Length, if supplied in more than one length.

NOTE 2—The run is that portion of the fitting which forms part of the main drain, waste or vent line. The spigot end is ordinarily the outlet.

8.2 *Method of Specifying Hand of Fittings with Side Inlets and Outlets*—When placed in the position described below, if

the side inlet or outlet appears on the right, it is a right-hand fitting; if on the left, it is a left-hand fitting.

8.2.1 *Bends and Offsets*—Place the fitting with hub facing toward the observer and the spigot end lower than the hub.

8.2.2 *Branch Fittings*—Place the branch toward the observer and the spigot end lower than the hub.

8.2.3 *Traps*—Place in the position in which the trap is installed, with the hub toward the observer.

8.2.4 The fittings shown in Fig. 2 have right-hand inlet or cleanout. Left-hand fittings have these openings on the side opposite to that shown. For details of side inlets, see Fig. 3.

## 9. Coating

9.1 The pipe and fittings shall be uniformly coated with a material suitable for the purpose, that is adherent, not brittle, and without a tendency to scale. The coating shall not contain asbestos above current MSDS reportable levels. Material safety data sheets shall be furnished by the coating manufacturer when requested. The coating shall be evenly and smoothly applied to all surfaces except threaded openings.

## 10. Sampling

10.1 Chemical and mechanical tests shall be made regularly and at sufficiently close intervals for adequate determinations of the significant chemical constituents and properties of the cast iron. Records of chemical analysis shall be maintained by the manufacturer by lot. Copies of these analyses shall be furnished to the purchaser when requested.

10.2 A lot shall consist of one of the following:

10.2.1 All the metal poured from a single heating in a batch type furnace,

10.2.2 All the metal from two or more batch type melting furnaces poured into a single ladle or a single casting.

10.2.3 All the metal poured from a continuous melting furnace for a given period of time between changes in charge, processing conditions, aim-for chemistry, or 4 hours, whichever is the shorter period.

10.2.3.1 The purchaser shall be permitted to agree to extend the 4 hours time period to 8 hours if the manufacturer is able to demonstrate sufficient process control to warrant such an extension.

## 11. Test Methods

11.1 *Gray Iron:*

11.1.1 *Tensile Strength Test*—Test bars shall be cast in accordance with the requirements of Specification A 48. See Fig. 4 (Tension Test Specimens) for the machined test bar

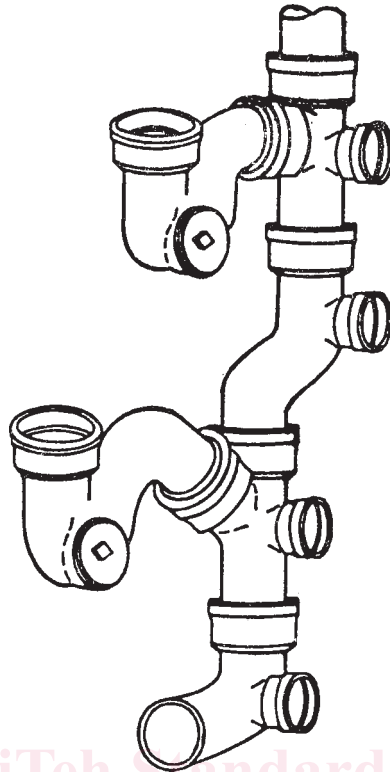
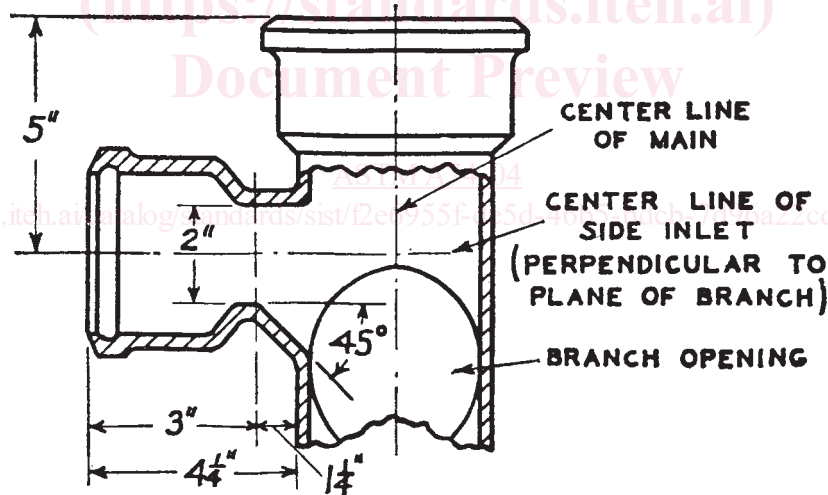

FIG. 2 Fittings with Right-Hand Inlet or Cleanout



NOTE 1—1 in. = 25.4 mm.

NOTE 2—Dimensions and location of 2-in. side inlet for single or double sanitary T branches and Y branches are shown above. Single and double sanitary T branches and single and double Y branches with 2-in. side inlets are standard in the following sizes only: 4 by 3 by 2-in.; 4 by 4 by 2-in.; 5 by 4 by 2-in.; 6 by 4 by 2-in.

FIG. 3 Dimensions and Locations for 2-in. Side Inlets

dimensions and as cast test bar dimensions. The tensile strength shall be determined in accordance with Test Methods E 8.

11.1.2 Tension test reports shall include breaking load of test bars, machined diameter of test bar, and calculated tensile strength.

## 12. Inspection

12.1 *Inspection and Test by the Manufacturer*—Pipe and fittings shall be inspected by the manufacturer to verify compliance with this standard. The manufacturer shall maintain a record of all inspections for a period of 7 years.

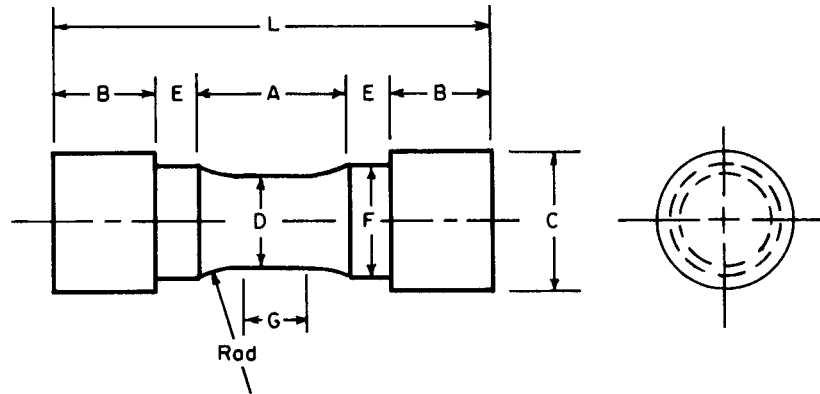

Dimensions, in. [mm]		Tension Test Specimen B
G—Length of parallel, min		0.75 [19]
D—Diameter		0.750 ± 0.015 [19.0 ± 0.38]
R—Radius of fillet, min		1 [25]
A—Length of reduced section, min		1½ [38]
L—Over-all length, min		4 [100]
C—Diameter of end section, approx		1¼ [32]
E—Length of shoulder, min		¼ [6]
F—Diameter of shoulder		15/16 ± 1/64 [25 ± 0.4]
B—Length of end section		A
As-Cast Diameter, in. (mm) / Length, in. (mm)		
Test Bar	Nominal (Mid-Length)	Minimum (Bottom)      Maximum (Top)      Minimum (Specified)      Maximum (Recommended)
B	1.20 (30.5)	1.14 (29.0)      1.32 (33.5)      6.0 (150)      9.0 (230)

<sup>A</sup> Optional to fit holders on testing machine. If threaded, root diameter shall not be less than dimension F.

FIG. 4 Tension-Test Specimens

**13. Certification**

13.1 *Certification by Manufacturer*—Upon request the purchaser shall be furnished certification by the manufacturer, stating samples representing each lot have been tested and inspected as indicated in this specification and the requirements have been met. If requested by the purchaser, certification shall be accompanied by test reports as prepared in accordance with the Test Methods section of this standard (see 11) . Certification shall include the legal name and address of the manufacturer.

**14. Product Marking**

14.1 Each length of pipe and each fitting shall be plainly marked with the country of origin, the manufacturer’s name or registered trademark by which the manufacturer can be readily identified after installation, and with letters to indicate the proper classification, as follows:

XH	Extra Heavy
SV	Service

The marking shall be cast, stenciled, or otherwise applied on the pipe so as to be clear and legible after installation. The marking shall be cast in raised letters on fittings and shall be clear and legible after installation and located away from the spigot end so as not to interfere with proper joining upon installation.

14.2 Each pipe shall be marked with the date of manufacture. The marking shall be stenciled on the pipe or otherwise applied to be clear and legible.

**15. Packaging and Package Marking**

15.1 *Government Procurement*—Unless otherwise specified in the contract, the material shall be packaged in accordance with the supplier’s standard practice which will be acceptable to the carrier at lowest rates. Containers and packing shall comply with Uniform Freight Classification Rules<sup>5</sup> or National Motor Freight Classification Rules.<sup>6</sup> Marking for shipment of such material shall be in accordance with Fed. Std. No. 123 for civil agencies and MIL-STD-129 for military agencies.

**16. Keywords**

16.1 cast iron; fitting; hub and spigot pipe; pipe; soil pipe

<sup>5</sup> Available from The Uniform Classification Commission, Room 1106, 222 S. Riverside Plaza, Chicago, IL 60606.

<sup>6</sup> Available from National Motor Freight Inc., 1616 P. St., N.W., Washington, DC 20036.

TABLE 1 Dimensions of Hubs, Spigots, and Barrels for Extra-Heavy and Service Cast Iron Soil Pipe and Fittings, in.

NOTE—1 in. = 25.4 mm; 1 ft = 0.3 m throughout tables.

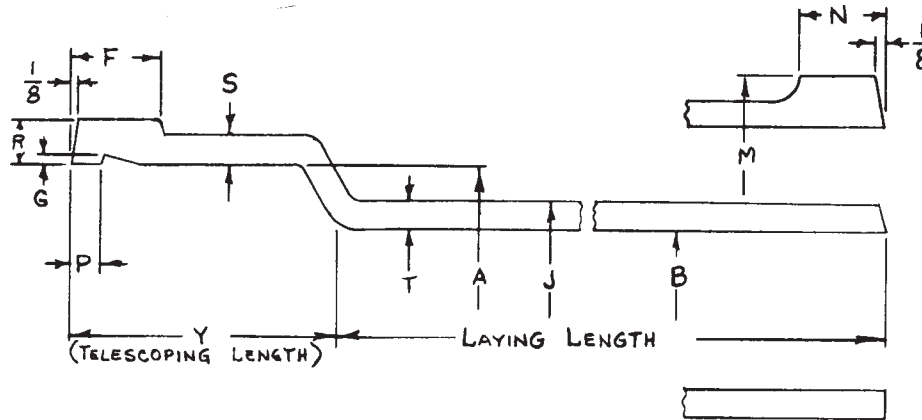

Extra-Heavy Cast Iron Soil Pipe and Fittings:

Size <sup>A</sup> Availability	Inside Diameter of Hub <sup>B</sup>	Outside Diameter of Barrel <sup>B</sup>	Telescoping Length <sup>B</sup>	Inside Diameter of Barrel <sup>B</sup>	Thickness of Barrel <sup>B</sup>	
	A	J	Y	B	T	
					Nom	Min
2*	3.06 [77.72]	2.38 [60.45]	2.50 [63.5]	2.00 [50.8]	0.19 [4.83]	0.16 [4.06]
3*	4.19 [106.43]	3.50 [88.9]	2.75 [69.85]	3.00 [76.2]	0.25 [6.35]	0.22 [5.59]
4*	5.19 [131.83]	4.50 [114.3]	3.00 [76.2]	4.00 [101.6]	0.25 [6.35]	0.22 [5.59]
5*	6.19 [157.23]	5.50 [139.7]	3.00 [76.2]	5.00 [127]	0.25 [6.35]	0.22 [5.59]
6*	7.19 [182.63]	6.50 [165.1]	3.00 [76.2]	6.00 [152.4]	0.25 [6.35]	0.22 [5.59]
8*	9.50 [241.30]	8.62 [218.5]	3.50 [88.9]	8.00 [203.2]	0.31 [7.87]	0.25 [6.35]
10*	11.62 [295.15]	10.75 [273.05]	3.50 [88.9]	10.00 [254]	0.37 [9.40]	0.31 [7.87]
12*	13.75 [349.25]	12.75 [323.85]	4.25 [107.95]	12.00 [304.8]	0.37 [9.40]	0.31 [7.87]
15*	16.95 [430.53]	15.88 [403.35]	4.25 [107.95]	15.00 [381]	0.44 [11.18]	0.38 [9.65]

Size <sup>A</sup>	Thickness of Hub		Width of Hub Bead <sup>B,C</sup>	Distance from Lead Groove to End, Pipe and Fittings <sup>B</sup>	Depth of Lead Groove	
	Hub Body	Over Bead			G (min)	G (max)
	S (min)	R (min)	F	P	G (min)	G (max)
2	0.18 [4.57]	0.37 [9.40]	0.75 [19.05]	0.22 [5.59]	0.10 [2.54]	0.19 [4.83]
3	0.25 [6.35]	0.43 [10.92]	0.81 [20.57]	0.22 [5.59]	0.10 [2.54]	0.19 [4.83]
4	0.25 [6.35]	0.43 [10.92]	0.88 [22.35]	0.22 [5.59]	0.10 [2.54]	0.19 [4.83]
5	0.25 [6.35]	0.43 [10.92]	0.88 [22.35]	0.22 [5.59]	0.10 [2.54]	0.19 [4.83]
6	0.25 [6.35]	0.43 [10.92]	0.88 [22.35]	0.22 [5.59]	0.10 [2.54]	0.19 [4.83]
8	0.34 [8.64]	0.59 [14.99]	1.19 [30.23]	0.38 [9.65]	0.15 [3.81]	0.22 [5.59]
10	0.40 [10.16]	0.65 [16.51]	1.19 [30.23]	0.38 [9.65]	0.15 [3.81]	0.22 [5.59]
12	0.40 [10.16]	0.65 [16.51]	1.44 [36.54]	0.47 [11.94]	0.15 [3.81]	0.22 [5.59]
15	0.46 [11.68]	0.71 [18.03]	1.44 [36.54]	0.47 [11.94]	0.15 [3.81]	0.22 [5.59]

Service Cast Iron Soil Pipe:

Size <sup>A</sup> Availability <sup>B</sup>	Inside Diameter of Hub <sup>B</sup>	Outside Diameter of Barrel <sup>D</sup>	Telescoping Length <sup>D</sup>	Inside Diameter of Barrel <sup>D</sup>	Thickness of Barrel <sup>D</sup>	
	A	J	Y	B	T	
					Nom	Min
20	2.94 [74.68]	2.30 [58.42]	2.50 [63.5]	1.96 [49.78]	0.17 [4.32]	0.14 [3.56]
30	3.94 [100.08]	3.30 [83.82]	2.75 [69.85]	2.96 [75.18]	0.17 [4.32]	0.14 [3.56]
40	4.94 [125.48]	4.30 [109.22]	3.00 [76.2]	3.94 [100.08]	0.18 [4.57]	0.15 [3.81]
50	5.94 [150.88]	5.30 [134.62]	3.00 [76.2]	4.94 [125.48]	0.18 [4.57]	0.15 [3.81]
60	6.94 [176.28]	6.30 [160.02]	3.00 [76.2]	5.94 [150.88]	0.18 [4.57]	0.15 [3.81]
80	9.25 [234.95]	8.38 [212.85]	3.50 [88.9]	7.94 [201.68]	0.23 [5.84]	0.17 [4.32]
100	11.38 [289.05]	10.50 [266.70]	3.50 [88.9]	9.94 [252.48]	0.28 [6.86]	0.22 [5.59]
120	13.50 [342.9]	12.50 [317.5]	4.25 [107.95]	11.94 [303.28]	0.28 [6.86]	0.22 [5.59]
150	16.95 [430.53]	15.88 [403.35]	4.25 [107.95]	15.16 [385.06]	0.36 [9.14]	0.30 [7.62]

Size <sup>A</sup>	Thickness of Hub		Width of Hub Bead <sup>D</sup>	Distance from Lead Groove to End, Pipe and Fittings <sup>B</sup>	Depth of Lead Groove	
	Hub Body	Over Bead			G (min)	G (max)
	S (min)	R (min)	F (min)	P		
2	0.13 [3.30]	0.34 [8.64]	0.75 (0.63) [19.05] (16.00)	0.22 [5.59]	0.10 [2.54]	0.19 [4.83]
3	0.16 [4.06]	0.37 [9.40]	0.81 (0.63) [20.57] (16.00)	0.22 [5.59]	0.10 [2.54]	0.19 [4.83]
4	0.16 [4.06]	0.37 [9.40]	0.88 (0.63) [22.35] (16.00)	0.22 [5.59]	0.10 [2.54]	0.19 [4.83]
5	0.16 [4.06]	0.37 [9.40]	0.88 (0.63) [22.35] (16.00)	0.22 [5.59]	0.10 [2.54]	0.19 [4.83]
6	0.18 [4.57]	0.37 [9.40]	0.88 (0.63) [22.35] (16.00)	0.22 [5.59]	0.10 [2.54]	0.19 [4.83]
8	0.19 [4.83]	0.44 [11.26]	1.19 (1.06) [30.23] (26.92)	0.38 [9.65]	0.15 [3.81]	0.22 [5.59]
10	0.27 [6.86]	0.53 [13.46]	1.19 (1.06) [30.23] (26.92)	0.38 [9.65]	0.15 [3.81]	0.22 [5.59]
12	0.27 [6.86]	0.53 [13.46]	1.44 (1.31) [36.58] (33.27)	0.47 [11.94]	0.15 [3.81]	0.22 [5.59]
15	0.30 [7.62]	0.58 [14.73]	1.44 (1.31) [36.58] (33.27)	0.47 [11.94]	0.15 [3.81]	0.22 [5.59]

<sup>A</sup> Nominal inside diameter.

\* Indicates this item is made in extra heavy.

<sup>B</sup> For tolerances, see Table 2.

<sup>C</sup> Hub ends and spigot ends can be made with or without draft.

<sup>D</sup> Hub ends and spigot ends shall be permitted to be made with or without draft.

O Indicates this item is made in service weight.

# iTeh Standards (<https://standards.iteh.ai>) Document Preview

[ASTM A74-04](#)

<https://standards.iteh.ai/catalog/standards/sist/f2e6955f-de5d-46b5-bdcb-7d96a22cd452/astm-a74-04>

TABLE 2 Dimensional Tolerances for Extra-Heavy and Service Cast Iron Soil Pipe and Fittings, in.

NOTE 1—1 in. = 25.4 mm.

NOTE 2—The tolerances set forth in Table 2 are intended for pipe and fittings designed for use with lead and oakum joints; however, these same tolerances shall apply to pipe and fittings designed for use with a compression type gasket joint.

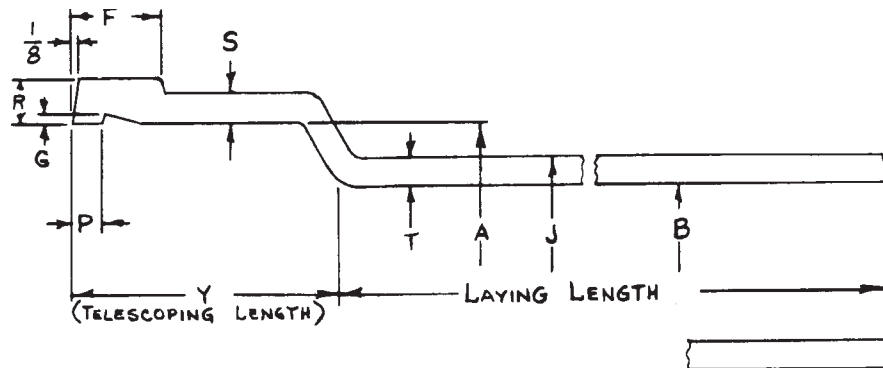

Size <sup>A</sup>	Inside Diameter of Hub	Outside Diameter of Barrel	Inside Diameter of Barrel	Telescoping Length	Laying Length			
	A'	J	B	Y	Pipe, 2½-, 3½-, 5-ft Lengths	Pipe, 10-ft Lengths	Fittings	
							Regular	Extra Long <sup>B</sup>
2	±0.06 [1.52]	±0.09 [±2.29]	±0.09 [±2.29]	±0.06 [±1.52]	±¼ [±6.35]	±½ [±12.7]	±⅛ [±3.18]	±⅛ [±1.59]
3	±0.09 [2.29]	±0.09 [±2.29]	±0.09 [±2.29]	±0.06 [±1.52]	±¼ [±6.35]	±½ [±12.7]	±⅛ [±3.18]	±⅛ [±1.59]
4	+0.09 [2.29] -0.06 [1.52]	±0.09 [±2.29]	±0.09 [±2.29]	±0.06 [±1.52]	±¼ [±6.35]	±½ [±12.7]	±⅛ [±3.18]	±⅛ [±1.59]
5	+0.09 [2.29] -0.06 [1.52]	±0.09 [±2.29]	±0.09 [±2.29]	±0.06 [±1.52]	±⅝ [±7.94]	±⅝ [±15.88]	±⅜ [±4.76]	±⅜ [±2.38]
6	+0.09 [2.29] -0.06 [1.52]	±0.09 [±2.29]	±0.09 [±2.29]	±0.06 [±1.52]	±⅝ [±7.94]	±⅝ [±15.88]	±⅜ [±4.76]	±⅜ [±2.38]
8	±0.13 [3.30]	±0.13 [±3.30]	±0.13 [±3.30]	±0.13 [±3.30]	±⅝ [±7.94]	±⅝ [±15.88]	±⅜ [±4.76]	±⅜ [±2.38]
10	±0.13 [3.30]	±0.13 [±3.30]	±0.13 [±3.30]	±0.13 [±3.30]	±¾ [±9.53]	±¾ [±19.05]	±¼ [±6.35]	±⅛ [±3.18]
12	±0.13 [3.30]	±0.19 [±4.83]	±0.19 [±4.83]	±0.19 [±4.83]	±¾ [±9.53]	±¾ [±19.05]	±¼ [±6.35]	±⅛ [±3.18]
15	±0.13 [3.30]	±0.19 [±4.83]	±0.19 [±4.83]	±0.19 [±4.83]	±¾ [±9.53]	±¾ [±19.05]	±¼ [±6.35]	±⅛ [±3.18]
		Size				Distance from Lead Groove to End, Pipe and Fittings		
						P		
		2				±0.09 [±1.52]		
		3				±0.09 [±1.52]		
		4				±0.09 [±1.52]		
		5				±0.09 [±1.52]		
		6				±0.09 [±1.52]		
		8				±0.09 [±1.52]		
		10				±0.09 [±1.52]		
		12				±0.11 [±2.79]		
		15				±0.11 [±2.79]		

<sup>A</sup> Nominal inside diameter.

<sup>B</sup> These tolerances apply to each foot of extra-long fittings in excess of regular laying lengths specified herein.



TABLE 3 Dimensions of One-Quarter Bends

NOTE 1—1 in. = 25.4 mm.

NOTE 2—Dimensions *D* and *X* are laying lengths.

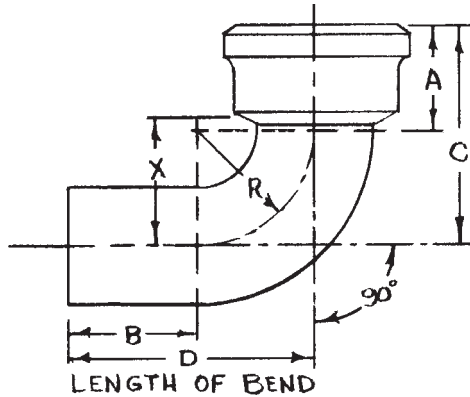

Size, in., Availability <sup>A</sup>	Dimensions in in. <sup>B</sup>					
	A	B	C	D	R	X
2°O	2¾ [70]	3 [76]	5¾ [146]	6 [152]	3 [76]	3¼ [83]
3°O	3¼ [83]	3½ [89]	6¾ [171]	7 [178]	3½ [89]	4 [102]
4°O	3½ [89]	4 [102]	7½ [191]	8 [203]	4 [102]	4½ [114]
5°O	3½ [89]	4 [102]	8 [203]	8½ [216]	4½ [114]	5 [127]
6°O	3½ [89]	4 [102]	8½ [216]	9 [229]	5 [127]	5½ [140]
8°O	4½ [105]	5½ [140]	10½ [257]	11½ [292]	6 [152]	6½ [168]
10°O	4½ [105]	5½ [140]	11½ [283]	12½ [318]	7 [178]	7½ [194]
12°O	5 [127]	7 [178]	13 [330]	15 [381]	8 [203]	8¾ [222]
15°O	5 [127]	7 [178]	14½ [368]	16½ [419]	9½ [241]	10¼ [260]

<sup>A</sup> \* indicates this item is made in extra heavy.

O indicates this item is made in service weight.

<sup>B</sup> For details of hubs and spigots, see Table 1.

ASTMA74-04

<https://standards.itech.ai/catalog/standards/sist/f2e6955f-de5d-46b5-bdc6-7d96a22cd452/astm-a74-04>

TABLE 4 Dimensions of Long One-Quarter Bends

NOTE 1—1 in. = 25.4 mm.

NOTE 2—Dimensions *D* and *X* are laying lengths.

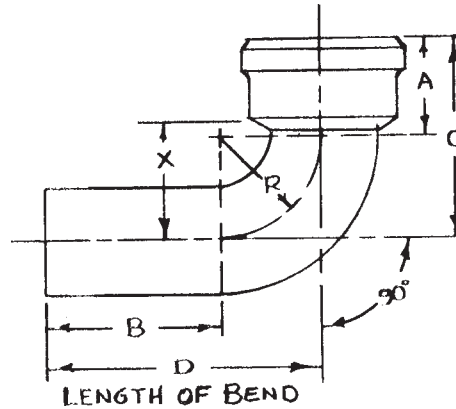

Size, in., Availability <sup>A</sup>	Dimensions in in. <sup>B</sup>					
	A	B	C	D	R	X
2 by 12°O	2¾ [76]	9 [229]	5¾ [146]	12 [305]	3 [76]	3¼ [83]
2 by 18°O	2¾ [76]	15 [381]	5¾ [146]	18 [457]	3 [76]	3¼ [83]
2 by 24°O	2¾ [76]	21 [533]	5¾ [146]	24 [610]	3 [76]	3¼ [83]
3 by 12°O	3¼ [83]	8½ [216]	6¾ [171]	12 [305]	3½ [89]	4 [102]
3 by 18°O	3¼ [83]	14½ [368]	6¾ [171]	18 [457]	3½ [89]	4 [102]
3 by 24°O	3¼ [83]	20½ [521]	6¾ [171]	24 [610]	3½ [89]	4 [102]
4 by 12°O	3½ [89]	8 [203]	7½ [191]	12 [305]	4 [102]	4½ [114]
4 by 18°O	3½ [89]	14 [356]	7½ [191]	18 [457]	4 [102]	4½ [114]
4 by 24°O	3½ [89]	20 [508]	7½ [191]	24 [610]	4 [102]	4½ [114]

<sup>A</sup> \* indicates this item is made in extra heavy.

O indicates this item is made in service weight.

<sup>B</sup> For details of hubs and spigots, see Table 1.

TABLE 5 Dimensions of Long Low-Hub One-Quarter Bends

NOTE 1—1 in. = 25.4 mm.

NOTE 2—Dimensions *D* and *X* are laying lengths.

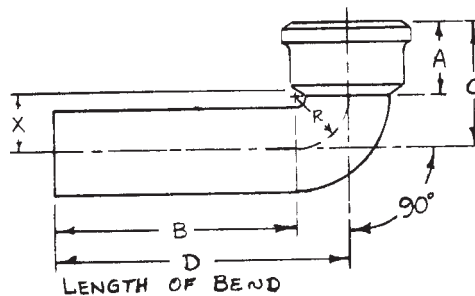

Size, in., Availability <sup>A</sup>	Dimensions in in. <sup>B</sup>					
	A	B	C	D	R	X
4 by 12O	3 [76]	9¼ [235]	5¾ [146]	12 [305]	2¾ [70]	2¾ [70]
4 by 14O	3 [76]	11¼ [286]	5¾ [146]	14 [356]	2¾ [70]	2¾ [70]
4 by 16O	3 [76]	13¼ [337]	5¾ [146]	16 [406]	2¾ [70]	2¾ [70]
4 by 18O	3 [76]	15¼ [387]	5¾ [146]	18 [457]	2¾ [70]	2¾ [70]

<sup>A</sup> O indicates this item is made in service weight.

<sup>B</sup> For details of hubs and spigots, see Table 1.

TABLE 6 Dimensions of One-Quarter Bends with Low Heel Inlet

NOTE 1—1 in. = 25.4 mm.

NOTE 2—Dimensions *D*, *X*, and *X'* are laying lengths

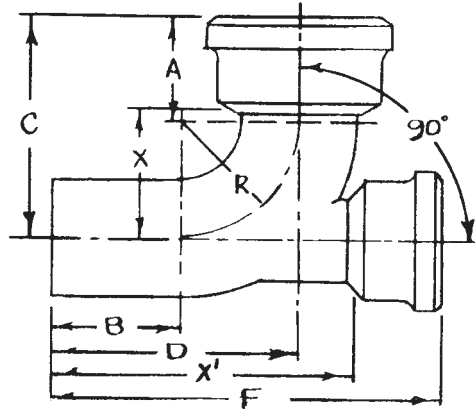

Size, in., Availability <sup>A</sup>	Dimensions in in. <sup>B</sup>							
	A	B	C	D	F	R	X	X'
3 by 2O	3¼ [83]	3½ [89]	6¾ [172]	7 [178]	11½ [292]	3½ [89]	4 [102]	9 [229]
4 by 2°O	3½ [89]	4 [102]	7½ [191]	8 [203]	13 [330]	4 [102]	4½ [114]	10½ [267]

<sup>A</sup>\* indicates this item is made in extra heavy.

O indicates this item is made in service weight.

<sup>B</sup> For details of hubs and spigots, see Table 1.

TABLE 7 Dimensions of Quarter Bends with High Heel Inlet

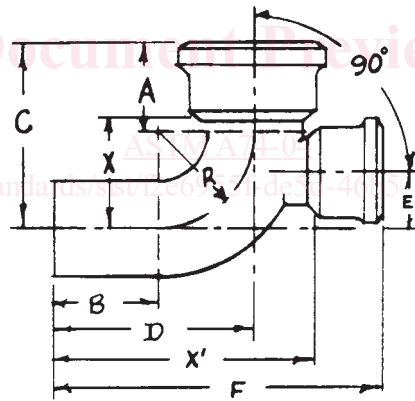

Size, in., Availability <sup>A</sup>	Dimensions in in. <sup>B</sup>								
	A	B	C	D	E	F	R	X	X'
4 by 2°O	3½ [89]	4 [102]	7½ [191]	8 [203]	2¾ [70]	13 [330]	4 [102]	4½ [114]	10½ [267]

<sup>A</sup>\* indicates this item is made in extra heavy.

O indicates this item is made in service weight.

<sup>B</sup> For details of hubs and spigots, see Table 1.

TABLE 8 Dimensions of Short and Long Sweep Bends

NOTE 1—1 in. = 25.4 mm.

NOTE 2—Dimensions *D* and *X* are laying lengths.

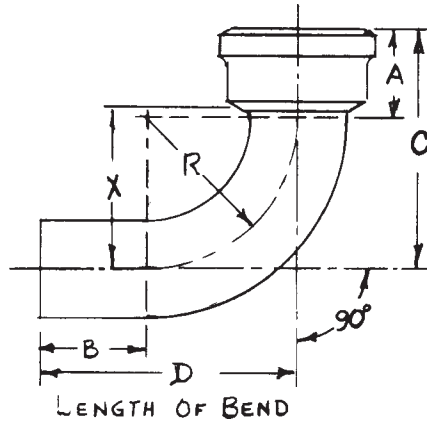

Short Sweep Bends:

Size, in.	Dimensions in in. <sup>A</sup>					
	A	B	C	D	R	X
2°O	2¾ [70]	3 [76]	7¾ [197]	8 [203]	5 [127]	5¼ [133]
3°O	3¼ [83]	3½ [89]	8¾ [222]	9 [229]	5½ [140]	6 [152]
4°O	3½ [89]	4 [102]	9½ [241]	10 [254]	6 [152]	6½ [165]
5°O	3½ [89]	4 [102]	10 [254]	10½ [267]	6½ [165]	7 [178]
6°O	3½ [89]	4 [102]	10½ [267]	11 [279]	7 [178]	7½ [191]
8°O	4¼ [105]	5½ [140]	12½ [308]	13½ [343]	8 [203]	8⅝ [219]
10°O	4¼ [105]	5½ [140]	13⅝ [333]	14½ [368]	9 [229]	9⅝ [244]
12°O	5 [127]	7 [178]	15 [381]	17 [432]	10 [254]	10¾ [273]
15°O	5 [127]	7 [178]	16½ [419]	18½ [470]	11½ [292]	12¼ [311]

<sup>A</sup> For details of hubs and spigots, see Table 1.

Long Sweep Bends:

Size, in., Availability <sup>A</sup>	Dimensions in in. <sup>B</sup>					
	A	B	C	D	R	X
2°O	2¾ [70]	3 [76]	10¾ [273]	11 [279]	8 [203]	8¼ [210]
3°O	3¼ [83]	3½ [89]	11¾ [298]	12 [305]	8½ [216]	9 [229]
4°O	3½ [89]	4 [102]	12½ [318]	13 [330]	9 [229]	9½ [241]
5°O	3½ [89]	4 [102]	13 [330]	13½ [343]	9½ [241]	10 [254]
6°O	3½ [89]	4 [102]	13½ [343]	14 [356]	10 [254]	10½ [267]
8°O	4¼ [105]	5½ [140]	15⅝ [384]	16½ [419]	11 [279]	11⅝ [295]
10°O	4¼ [105]	5½ [140]	16⅝ [410]	17½ [445]	12 [305]	12⅝ [321]
12°O	5 [127]	7 [178]	18 [457]	20 [508]	13 [330]	13¾ [349]
15°O	5 [127]	7 [178]	19½ [495]	21½ [546]	14½ [368]	15¼ [387]

<sup>A</sup> \* indicates this item is made in extra heavy.

O indicates this item is made in service weight.

<sup>B</sup> For details of hubs and spigots, see Table 1.