

# SLOVENSKI STANDARD

## SIST EN 13451-3:2011

01-december-2011

Nadomešča:

SIST EN 13451-3:2002

SIST EN 13451-8:2002

---

### Oprema za plavalne bazene - 3. del: Dodatne posebne varnostne zahteve in preskusne metode za bazenski pribor za pripravo vode

Swimming pool equipment - Part 3: Additional specific safety requirements and test methods for inlets and outlets and water/air based water leisure features

**iTeh STANDARD PREVIEW**

Schwimmbadgeräte - Teil 3: Zusätzliche besondere sicherheitstechnische Anforderungen und Prüfverfahren für Flansche und Auslässe

[SIST EN 13451-3:2011](https://standards.sih.si/catalog/standards/sis/en/13451-3-2011)

Equipement de piscine - Partie 3: Exigences de sécurité et méthodes d'essai complémentaires spécifiques pour les pièces d'aspiration et de refoulement et d'équipement de loisirs aquatiques

**Ta slovenski standard je istoveten z: EN 13451-3:2011**

---

#### **ICS:**

97.220.10      Športni objekti      Sports facilities

**SIST EN 13451-3:2011**      en,fr,de

**iTeh STANDARD PREVIEW**  
**(standards.iteh.ai)**

SIST EN 13451-3:2011

<https://standards.iteh.ai/catalog/standards/sist/e1ee230c-fc32-4424-bdc5-d50452fe1816/sist-en-13451-3-2011>

EUROPEAN STANDARD

EN 13451-3

NORME EUROPÉENNE

EUROPÄISCHE NORM

September 2011

ICS 97.220.10

Supersedes EN 13451-3:2001, EN 13451-8:2001

English Version

## Swimming pool equipment - Part 3: Additional specific safety requirements and test methods for inlets and outlets and water/air based water leisure features

Équipement de piscine - Partie 3: Exigences de sécurité et méthodes d'essai complémentaires propres aux pièces d'aspiration et de refoulement et aux équipements de loisirs aquatiques disposant d'introduction et d'extraction d'eau/d'air

Schwimmbadgeräte - Teil 3: Zusätzliche besondere sicherheitstechnische Anforderungen und Prüfverfahren für Ein- und Ausläufe sowie Wasser-Luftattraktionen

This European Standard was approved by CEN on 29 July 2011.

CEN members are bound to comply with the CEN/CENELEC Internal Regulations which stipulate the conditions for giving this European Standard the status of a national standard without any alteration. Up-to-date lists and bibliographical references concerning such national standards may be obtained on application to the CEN-CENELEC Management Centre or to any CEN member.

This European Standard exists in three official versions (English, French, German). A version in any other language made by translation under the responsibility of a CEN member into its own language and notified to the CEN-CENELEC Management Centre has the same status as the official versions.

CEN members are the national standards bodies of Austria, Belgium, Bulgaria, Croatia, Cyprus, Czech Republic, Denmark, Estonia, Finland, France, Germany, Greece, Hungary, Iceland, Ireland, Italy, Latvia, Lithuania, Luxembourg, Malta, Netherlands, Norway, Poland, Portugal, Romania, Slovakia, Slovenia, Spain, Sweden, Switzerland and United Kingdom.



EUROPEAN COMMITTEE FOR STANDARDIZATION  
COMITÉ EUROPÉEN DE NORMALISATION  
EUROPÄISCHES KOMITEE FÜR NORMUNG

Management Centre: Avenue Marnix 17, B-1000 Brussels

## Contents

Page

Foreword.....	3
<b>1 Scope .....</b>	<b>4</b>
<b>2 Normative references .....</b>	<b>4</b>
<b>3 Terms and definitions .....</b>	<b>4</b>
<b>4 Safety requirements .....</b>	<b>6</b>
4.1 General.....	6
4.2 Structural integrity.....	6
4.3 Water speed at inlets.....	8
4.4 Hair entrapment .....	8
4.5 Slip resistance of grilles .....	8
4.6 Risk of suction entrapment .....	8
4.7 Positioning of leisure features .....	11
4.8 Stream channels and rivers.....	11
4.9 Additional requirements for specific leisure features .....	12
<b>5 Test methods.....</b>	<b>14</b>
5.1 General.....	14
5.2 Structural integrity.....	14
5.3 Hair entrapment test.....	17
<b>6 Documentation.....</b>	<b>21</b>
<b>Annex A (informative) Obstruction test for floor outlets suction grills .....</b>	<b>22</b>
A.1 General.....	22
A.2 Test device .....	22
A.3 Water flow.....	24
A.4 Procedure .....	24
A.5 Evaluation.....	24
<b>Annex B (informative) Water speed .....</b>	<b>25</b>
B.1 General.....	25
B.2 Calculation methods .....	25
B.3 Test Methods.....	25
B.4 Design stage.....	26
B.5 Suction points in operation .....	27
<b>Annex C (normative) Entrapment of hair in slits .....</b>	<b>28</b>
C.1 Testing equipment.....	28
C.2 Test method.....	28
C.3 Evaluation.....	28
<b>Bibliography .....</b>	<b>29</b>

## Foreword

This document (EN 13451-3:2011) has been prepared by Technical Committee CEN/TC 136 "Sports, playground and other recreational facilities and equipment", the secretariat of which is held by DIN.

This European Standard shall be given the status of a national standard, either by publication of an identical text or by endorsement, at the latest by March 2012, and conflicting national standards shall be withdrawn at the latest by September 2012.

Attention is drawn to the possibility that some of the elements of this document may be the subject of patent rights. CEN [and/or CENELEC] shall not be held responsible for identifying any or all such patent rights.

This document supersedes EN 13451-3:2001 and EN 13451-8:2001.

The European Standard EN 13451 *Swimming pool equipment* consists of:

- *Part 1: General safety requirements and test methods;*
- *Part 2: Additional specific safety requirements and test methods for ladders, stepladders and handle bends;*
- *Part 3: Additional specific safety requirements and test methods for inlets and outlets and water/air based water leisure features;*
- *Part 4: Additional specific safety requirements and test methods for starting platforms;*
- *Part 5: Additional specific safety requirements and test methods for lane lines;*
- *Part 6: Additional specific safety requirements and test methods for turning boards;*
- *Part 7: Additional specific safety requirements and test methods for water polo goals;*
- *Part 10: Additional specific safety requirements and test methods for diving platforms, diving springboards and associated equipment;*
- *Part 11: Additional specific safety requirements and test methods for moveable pool floors and moveable bulkheads.*

In relation to EN 13451-3:2001 and EN 13451-8:2001, the following main amendments have been made:

- a) requirements of EN 13451-8:2001 were incorporated;
- b) requirements of the hair entrapment tests were changed;
- c) test methods have been widened and improved.

According to the CEN/CENELEC Internal Regulations, the national standards organizations of the following countries are bound to implement this European Standard: Austria, Belgium, Bulgaria, Croatia, Cyprus, Czech Republic, Denmark, Estonia, Finland, France, Germany, Greece, Hungary, Iceland, Ireland, Italy, Latvia, Lithuania, Luxembourg, Malta, Netherlands, Norway, Poland, Portugal, Romania, Slovakia, Slovenia, Spain, Sweden, Switzerland and the United Kingdom.

**EN 13451-3:2011 (E)****1 Scope**

This European Standard specifies safety requirements and test methods for inlets and outlets for water/air and water/air based leisure features involving water movement, in addition to the general safety requirements of EN 13451-1:2011.

The requirements of this specific standard take priority over those in EN 13451-1:2011.

This part of EN 13451 is applicable to swimming pool equipment designed for:

- the introduction and/or extraction of water for treatment or leisure purposes;
- the introduction of air for leisure purposes;
- water leisure features involving the movement of water.

NOTE The above items are identified with the general term devices.

**2 Normative references**

The following referenced documents are indispensable for the application of this document. For dated references, only the edition cited applies. For undated references, the latest edition of the referenced document (including any amendments) applies.

EN 1069-1, *Water slides — Part 1: Safety requirements and test methods*

EN 13451-1:2011, *Swimming pool equipment — Part 1: General safety requirements and test methods*

EN 15288-1, *Swimming pools — Part 1: Safety requirements for design*

EN 15288-2, *Swimming pools — Part 2: Safety requirements for operation*

**3 Terms and definitions**

For the purposes of this document, the terms and definitions given in EN 13451-1:2011 and the following apply.

**3.1 floor/wall inlet**

device designed to be installed into the pool floor/wall for introducing water/air in the pool

**3.2 floor water outlet**

device designed to be installed into the pool floor, for the extraction of water, by gravity or by suction

**3.3 wall water outlet**

device designed to be installed into the pool wall for the extraction of water, by gravity or by suction

**3.4 sump**

vessel between the suction outlet grille and the suction outlet piping, manufactured or field built

**3.5****skimmer**

device designed to skim the uppermost layer of water only and return it to the filtration system

**3.6****overflow channel**

channel to take in the overflowing water of the related basin, as part of the filtration circuit

NOTE An overflow channel could be located, e.g. at deck level; built into the basin wall.

**3.7****grille**

component to cover any opening, designed to allow the passage of water and/or air

EXAMPLE A grille could be an inlet grille, an outlet grille, an overflow channel grille, a deck level channel grille.

**3.8****cover**

protection device or assembly that separates the user from hazards caused by an opening

**3.9****water speed**

water flow through velocity in the open cross section of an opening

**3.10****air speed**

air flow through velocity in the open cross section of an opening

**3.11****open cross section of a grille**

sum of all single open sections of the grille as designed through which the corresponding flow rate can flow

**3.12****water operated leisure feature**

feature formed as a result of water, being emitted either into or from a swimming pool

EXAMPLE Waves, water cannons, rain sprays, waterfalls, mushrooms and rapid rivers.

**3.13****air operated leisure feature**

feature formed as a result of air, being emitted into swimming pool water

EXAMPLE Geysers, bubble seats.

**3.14****air and water operated leisure feature**

feature formed as a result of air and water, being concurrently emitted into or from a swimming pool

EXAMPLE Hydromassages.

**3.15****integrated swim jet system**

device that incorporates suction outlet and inlet in a single housing that is designed to move a large volume of water at high velocity one directional

**3.16****gravity feed tank**

tank that is filled by pool water flowing by gravity only, intended as a separation element between the pool and the suction pumps

**EN 13451-3:2011 (E)****3.17****vacuum release system**

system or device capable of providing vacuum release at a suction outlet in case of a high vacuum occurrence due to suction outlet flow blockage

**3.18****vortex pool**

pool characterised by swirling water movement

**4 Safety requirements****4.1 General**

As the components defined in Clause 3 are integral parts of an overall system, special attention shall be paid to the system design criteria, especially taking into consideration the interaction between different components.

Where leisure water features are created by the introduction of air and/or water under pressure into the pool water, the safety of the users shall be provided by means of a risk assessment according to EN 15288-1 and EN 15288-2, including consideration of their design, location, method of operation, warning signals and supervision.

**4.2 Structural integrity****4.2.1 Floor inlets**

Floor inlets shall be tested for:

- vertical load and deformation according to 5.2.2;
- horizontal load and deformation, if applicable, according to 5.2.3;
- point load according to 5.2.4;
- shear load, if applicable according to 5.2.5.

**4.2.2 Wall inlets**

Wall inlets installed between water level and 800 mm depth shall be designed to withstand a load equivalent to 100 % of the load according to EN 13451-1:2011, A.2.2.

Wall inlets installed > 800 mm below water level shall be designed to withstand a load equivalent to 10 % of the load according to EN 13451-1:2011, A.2.2.

Wall inlets shall be tested for:

- horizontal load and deformation, if applicable, according to 5.2.3;
- point load according to 5.2.4;
- shear load, if applicable, according to 5.2.5.

**4.2.3 Floor and wall water outlets**

Floor and wall water outlets shall be designed to withstand the load according to EN 13451-1:2011, A.2.2.

**iTeh STANDARD PREVIEW**  
(standards.iteh.ai)

SIST EN 13451-3:2011

<https://standards.iteh.ai/catalog/standards/sist/e1ee230c-fc32-4424-bdc5-d50452fe1816/sist-en-13451-3-2011>



Floor and wall water outlets shall be tested for:

- vertical load and deformation, according to 5.2.2;
- horizontal load and deformation, if applicable, according to 5.2.3;
- point load according to 5.2.4;
- shear load, if applicable, according to 5.2.5;
- vacuum and point impact according to 5.2.6;
- hair entrapment in accordance with 5.3.

#### 4.2.4 Grilles

##### 4.2.4.1 General

Grilles and their substructure shall be designed to withstand the load according to EN 13451-1:2011, A.2.2 related to their shape (point, line or area load).

Grilles shall be tested for vertical load and deformation, in accordance with 5.2.2.

In case of manufactured substructures (e.g. overflow channel) also the complete assembly of grill and substructure shall be tested for vertical load and deformation in accordance with 5.2.2.

##### 4.2.4.2 Grilles for overflow channels

Grilles made up from separate elements shall remain interconnected under conditions of use.

Grilles shall be designed to remain in position and to prevent their movement when subject to normal conditions of use.

##### 4.2.5 Skimmer weir

As the floating weir is an essential component for skimming the uppermost layer of the water only, it shall be always properly working. It shall be removable only by intentional manoeuvre or with the use of tools.

##### 4.2.6 Skimmer top covers

If the upper part of the skimmers is placed in a walkable area, it shall be designed to withstand the load according to EN 13451-1:2011, A.2.2.

Lids shall be removable only by intentional manoeuvre or with the use of tools.

Skimmer top covers shall be tested for vertical load and deformation according to 5.2.2.

##### 4.2.7 Overflow channels

When the overflow channel is designed to be covered by a grille, its supporting structure shall withstand the same load as the grille itself.

They shall pass the load test in accordance with 5.2.2.

**EN 13451-3:2011 (E)****4.3 Water speed at inlets**

The water speed at inlets shall be  $\leq 15$  m/s, except for vertical injection from the swimming pool floor in water depth  $< 700$  mm, where it shall be  $\leq 2$  m/s.

NOTE Typical values of water speed are:

- inlet for circulation for water treatment purposes:  $\leq 4$  m/s;
- water leisure features (e. g. hydromassages, swim jets and cannons)  $\leq 15$  m/s

For water speed test see Annex B.

**4.4 Hair entrapment**

Wall water outlets and floor water outlets shall pass the hair entrapment test in accordance with 5.3.

**4.5 Slip resistance of grilles**

Slip resistance of any walkable grilles shall comply with the requirements in accordance with EN 13451-1:2011, Table 1.

**4.6 Risk of suction entrapment****4.6.1 General**

**iTeh STANDARD PREVIEW**  
(standards.iteh.ai)

Suction devices shall be designed and installed so as to reduce the potential for entrapment of the user.

Water speed at outlets shall be  $\leq 0,5$  m/s. [SIST EN 13451-3:2011](https://standards.iteh.ai/catalog/standards/sist/e1ee230c-fc32-4424-bdc5-13451-3-2011)

Additionally at least one of the following requirements shall be met: <https://standards.iteh.ai/catalog/standards/sist/e1ee230c-fc32-4424-bdc5-13451-3-2011>

- a) multiple suction outlet system designed in such a way that:
  - 1) a minimum of two functioning suction outlets per pump are installed;
  - 2) the distance between the nearest points of the perimeters of the devices is  $\geq 2$  m;
  - 3) if anyone of the suction outlets becomes blocked, the flow through the remaining suction outlet/s shall accommodate 100 % of the flow rate.
- b) in case of suction outlet systems with only one grille, the grille should be designed in such a way that
  - 1) one user can not cover more than 50 % of the opening;
  - 2) raised grilles domed opposite to the flow direction, with prevalent peripheric suction. The height of the dome shall be at least 10 % of the main dimension. Obstruction test are available (for an example see Annex A);
  - 3) single grilles with a surface of the area circumscribed to the suction openings  $\geq 1$  m<sup>2</sup> (see Figure 1).

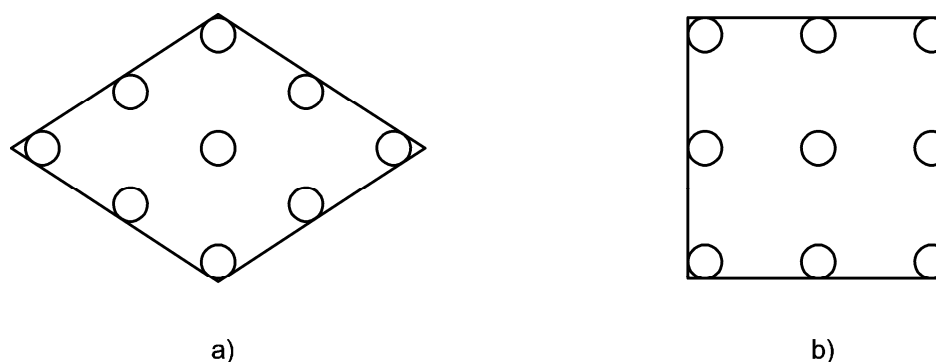

**Figure 1 — Identification of the area circumscribed to the suction openings**

c) a gravity feed tank.

NOTE 1 Frequency of testing should be determined by risk assessment.

When retrofitting existing installations that have a single suction outlet which does not comply with the requirements of this clause, then the following actions are required:

- the existing suction outlet shall be retrofitted with a grille conforming to b), or;
- one or more additional suction outlets shall be provided as in a) or;
- a gravity flow system fitted.

In addition to the requirements in a) to c), a vacuum release system may be provided.

Vacuum release systems typically respond to a blockage of a single outlet by:

- releasing the vacuum by turning the pump off;
- drawing water out of a vent tube to allow air into the suction system;
- mechanically operating valves to reverse flow through the suction outlet(s);
- opening a valve to atmosphere to cause a pump to lose prime.

All vacuum release systems shall be tested on outlets which meet the structural integrity and design requirements for grilles given earlier in this standard.

NOTE 2 These devices/systems are not considered “fail safe” systems as there is no known suction vacuum release system that will completely protect against all outlet entrapment hazards. Presenting Vacuum Release Systems as “fail safe” systems would promote a false sense of security among the users of these devices/systems.

Safety requirements a) to c) are not applicable to:

- skimmers, because they are vented (see 4.6.3) and partly above the water level;
- integrated swim jet systems, because the users are pushed away from the outlet by the action of the inlet.

NOTE 3 It is recommended to install at the deck an accessible general emergency switch for the pumps level.

## EN 13451-3:2011 (E)

## 4.6.2 Sumps for floor and wall water outlets

Manufactured or field built floor and wall water outlets shall have a sump with dimensions as shown in Figure 2.

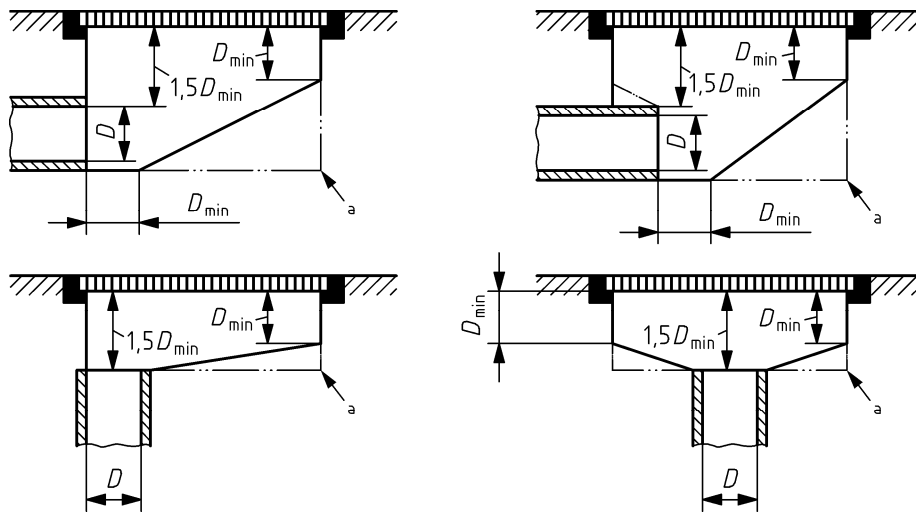

## Key

a indicates suggested sump configuration

$D$  inside diameter of the pipe

$D_{min}$  dimension  $\geq D$

**iTeh STANDARD PREVIEW**  
(standards.iteh.ai)

Figure 2 — Samples of sumps

## 4.6.3 Skimmers

SIST EN 13451-3:2011

<https://standards.iteh.ai/catalog/standards/sist/e1ee230c-fc32-4424-bdc5-d50452fe1816/sist-en-13451-3-2011>

Skimmers shall be effectively vented to atmosphere through openings in the lid (see Figure 3), or through a separate vent pipe.

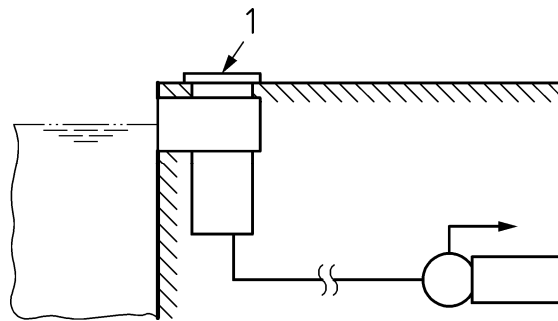

## Key

1 vent trough lid

Figure 3 — Skimmer, vent through lid

Skimmers shall fulfil all the general entrapment requirements in accordance with EN 13451-1; otherwise they shall be subjected to a specific risk assessment.