



Designation: E1165 – 04

Standard Test Method for Measurement of Focal Spots of Industrial X-Ray Tubes by Pinhole Imaging¹

This standard is issued under the fixed designation E1165; the number immediately following the designation indicates the year of original adoption or, in the case of revision, the year of last revision. A number in parentheses indicates the year of last reapproval. A superscript epsilon (ϵ) indicates an editorial change since the last revision or reapproval.

1. Scope

1.1 This test method provides instructions for determining the length and width dimensions of line focal spots in industrial X-ray tubes (see [Note 1](#)). This determination is based on the measurement of an image of a focal spot that has been radiographically recorded with a “pinhole” projection/imaging technique.

NOTE 1—Line focal spots are associated with vacuum X-ray tubes whose maximum voltage rating does not generally exceed 500 kV.

1.2 This test method may not yield meaningful results on focal spots whose nominal size is less than 0.3 mm (0.011 in.). (See [Note 2](#).)

NOTE 2—The X-ray tube manufacturer may be contacted for nominal focal spot dimensions.

1.3 This test method may also be used to determine the presence or extent of focal spot damage or deterioration that may have occurred due to tube age, tube overloading, and the like. This would entail the production of a focal spot radiograph (with the pinhole method) and an evaluation of the resultant image for pitting, cracking, and the like.

1.4 Values stated in SI units are to be regarded as the standard. Inch-pound units are provided for information only.

1.5 *This standard does not purport to address all of the safety concerns, if any, associated with its use. It is the responsibility of the user of this standard to establish appropriate safety and health practices and determine the applica-*

bility of regulatory limitations prior to use.

2. Referenced Documents

2.1 *ASTM Standards*:²

E999 *Guide for Controlling the Quality of Industrial Radiographic Film Processing*

3. Terminology

3.1 *Definitions of Terms Specific to This Standard:*

3.1.1 *actual focal spot*—the X-ray producing area of the target as viewed from a position perpendicular to the target surface (see [Fig. 2](#)).

3.1.2 *effective focal spot*—the X-ray producing area of the target as viewed from a position perpendicular to the tube axis in the center of the X-ray beam (see [Fig. 2](#)).

3.1.3 *line focal spot*—a focal spot whose projected pinhole image consists primarily of two curved lines (see [Fig. 3](#)).

4. Significance and Use

4.1 One of the factors affecting the quality of a radiographic image is geometric unsharpness. The degree of geometric unsharpness is dependent upon the focal size of the radiation source, the distance between the source and the object to be radiographed, and the distance between the object to be radiographed and the film. This test method allows the user to determine the focal size of the X-ray source and to use this result to establish source to object and object to film distances appropriate for maintaining the desired degree of geometric unsharpness.

¹ This test method is under the jurisdiction of ASTM Committee E07 on Nondestructive Testing and is the direct responsibility of Subcommittee E07.01 on Radiology (X and Gamma) Method.

Current edition approved January 1, 2004. Published February 2004. Originally approved in 1987. Last previous edition approved in 2002 as E1165 – 92 (2002). DOI: 10.1520/E1165-04.

² For referenced ASTM standards, visit the ASTM website, www.astm.org, or contact ASTM Customer Service at service@astm.org. For *Annual Book of ASTM Standards* volume information, refer to the standard's Document Summary page on the ASTM website.

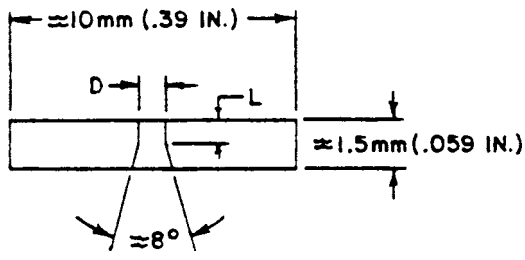

FIG. 1 Pinhole Diaphragm Design

5. Apparatus

5.1 *Pinhole Diaphragm*—The pinhole diaphragm shall conform to the design and material requirements of Table 1 and Fig. 1.

5.2 *Camera*—The pinhole camera assembly consists of the pinhole diaphragm, the shielding material to which it is affixed, and any mechanism that is used to hold the shield/diaphragm in position (jigs, fixtures, brackets, and the like; see Fig. 4).

5.3 *Film*—Industrial type extra fine grain. No intensifying screens are to be used. The film shall be processed in accordance with Guide E999.

5.4 *Image Measurement Apparatus*—This apparatus is used to measure the size of the image of the focal spot. The apparatus shall be an optical comparator with built-in graticule with 0.1 mm or .001 in., or both divisions and magnification of 5× to 10× (or equivalent).

6. Procedure

6.1 If possible, use a standard 91.44 cm (36 in.) focal spot to film plane distance (FFD) for all exposures. If machine geometry or accessibility limitations will not permit the use of a 91.44 cm (36 in.) FFD, use the maximum attainable FFD (in these instances adjust the relative distances between focal spot, pinhole, and film accordingly to suit the image enlargement factors specified in Table 2). The distance between the focal spot and the pinhole is based on the nominal size of the focal spot being measured and the desired degree of image enlargement (see Fig. 5). The specified focal spot to pinhole distance (FHD) for the different nominal focal spot size ranges is provided in Table 2. Position the pinhole such that it is within $\pm 1^\circ$ of the central axis of the X-ray beam. Fig. 6 illustrates a typical focal spot exposure arrangement.

NOTE 3—The accuracy of the pinhole system is highly dependent upon the relative distances between (and alignment of) the focal spot, the pinhole, and the film. Accordingly, specially designed apparatus may be necessary in order to assure compliance with the above requirements. Fig. 7 provides an example of a special collimator that can be used to ensure conformance with the $\pm 1^\circ$ alignment tolerance. Some other standards impose very stringent alignment requirements and express these requirements in terms of radial tolerances. These documents do not, however, address any means for assuring compliance with such tolerances. In order to simplify the focal spot radiography technique and to improve the overall practicality of the procedure, it is considered that a workable alignment tolerance, and a means of assuring conformance with that tolerance, is appropriate. Accordingly, this standard addresses tolerances in angular terms and provides a method for assuring compliance with these tolerances. This provides a practical means of meeting the precision and bias requirements of Section 9.

6.2 Position the film as illustrated in Fig. 6. The exposure identification appearing on the film (by radiographic imaging)

should be X-ray machine identity (that is, make and serial number), organization making the radiograph, and date of exposure.

6.3 Adjust the kilovoltage and milliamperage settings on the X-ray machine to that specified in Table 3.

6.4 Expose the film such that the density of the darkest portion of the focal spot image conforms to the limits specified in Table 4. Density measurement shall be as illustrated in Fig. 8.

6.5 Density shall be controlled by exposure time only.

6.6 Process the film in accordance with Guide E999.

6.6 *Focal Spot Measurement:*

6.6.1 *Back Lighting*—Back lighting shall be such that the focal spot image can be easily and comfortably viewed.

6.6.2 Place the magnification graticule (handheld optical comparator) in intimate contact with the film for the measurement determination. Determine an imaginary “box” that represents the perceptible edges of the focal spot image (see Fig. 9(a) for the extremities measurement).

6.6.3 Measure the focal spot image in two directions (see Fig. 9(b)):

6.6.3.1 Direction A—Parallel to the axis of the tube.

6.6.3.2 Direction B—Perpendicular to the axis of the tube.

7. Calculation of Results

7.1 Multiply the measured “A” direction dimension by a correction factor of 0.7 to determine the actual “A” dimension (see Notes 4 and 5). The measured “B” direction dimension is representative of actual size.

NOTE 4—The need for the 0.7 fractional multiplier for correction of the measured image length arises from the fact that the lengthwise distribution of energy in the focal spots of line-focus tubes tends to be peaked in the center and diminishes gradually to zero at the ends. Hence, the effective length, (that is, resultant effect on radiographic definition and film density distribution) cannot be stated as equal to the measured length.

NOTE 5—European standard EN 12543-2 describes a similar x-ray focal spot measurement method (pin-hole method), but does not use the “0.7” correction factor described within this standard. EN 12543-2, at the time of this revision, has a range of applications considered beyond the scope of E1165. International users of these standards should be aware of this difference for their particular applications.

7.2 If an image enlargement technique was used, divide the “A” and “B” direction measurements by the pertinent enlargement factor to obtain actual focal spot size (see Fig. 5 and Table 2).

8. Report

8.1 A report documenting the focal spot size determination should include the machine model number and serial number, the X-ray tube serial number, the focal spot(s) that was measured (some machines have dual focal spots), the set-up and exposure parameters (for example, kilovoltage, milliamps, enlargement factor, and the like), date, name of organization, and estimated beam time hours (if available).

9. Precision and Bias

9.1 Conformance to the requirements specified herein will produce results that are within the following tolerances:

9.1.1 *Technique*—The technique requirements specified herein will produce a focal spot image whose size is $\pm 5\%$ of the actual effective focal spot size.

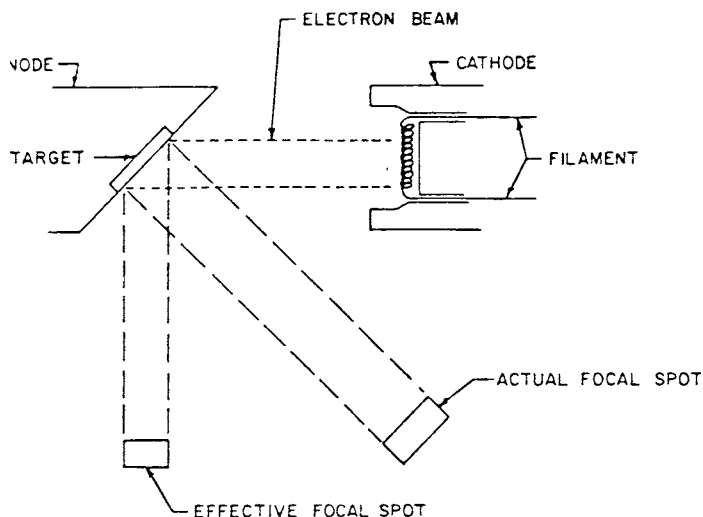
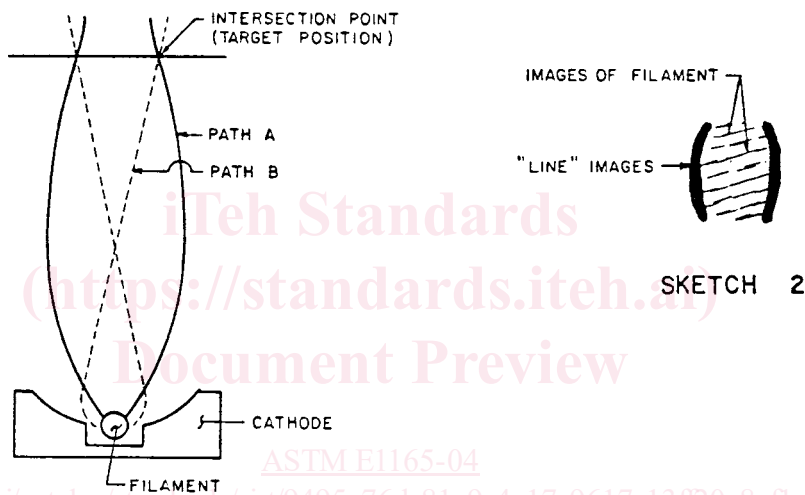

FIG. 2 Actual/Effective Focal Spot



SKETCH 1

SKETCH 2

NOTE 1—During the production of X-rays the electrons are accelerated from the filament to the target in two separate paths (see Sketch 1). Electrons emitted at the front of the filament travel primarily along Path A, and electrons emitted at the backside of the filament travel primarily along Path B. Note that these two paths intersect at a certain point; this is the point at which the target is positioned. As a result, the pinhole picture of the focal spot shows two lines that correspond with the intersections of Paths A and B at the target (see Sketch 2).

FIG. 3 Line Focal Spot

9.1.2 *Measurement*—The measurement requirements specified herein will produce results that are within the tolerances:

Nominal Focal Spot Size, mm (in.)	Measurement Tolerances
0.3 to 1.2 (0.011 to 0.046) incl	±30 %
>1.2 to 2.5 (0.046 to 0.097) incl	±25 %
>2.5 (0.097)	±20 %

10. Keywords

10.1 focal spots; pinhole camera; pinhole imaging; X-ray; X-ray tube

TABLE 1 Pinhole Diaphragm Design Requirements (Dimension)^A

NOTE 1—The pinhole diaphragm shall be made from one of the following materials:

- (1) An alloy of 90 % gold and 10 % platinum,
- (2) Tungsten,
- (3) Tungsten carbide,
- (4) Tungsten alloy,
- (5) Platinum and 10 % Iridium Alloy, or
- (6) Tantalum.

Nominal Dimension of Focal Spot, mm (in.) ^B	Nominal Diameter of Diaphragm Opening, mm (in.)	Required "D" and "L" Dimensions, mm (in.)	
		D	L
0.3 to 1.2 (0.011 to 0.046) incl	0.030 (0.0011)	0.030 ± 0.005 (0.0011 ± 0.0002)	0.075 ± 0.010 (0.0029 ± 0.0004)
>1.2 to 2.5 (0.046 to 0.097) incl	0.075 (0.0029)	0.075 ± 0.005 (0.0029 ± 0.0002)	0.350 ± 0.010 (0.014 ± 0.0004)
>2.5 (0.097)	0.100 (0.0039)	0.100 ± 0.005 (0.0039 ± 0.0002)	0.500 ± 0.010 (0.02 ± 0.0004)

^A See Fig. 1.

^B Nominal focal spot dimensions may be obtained from the X-ray tube manufacturer.

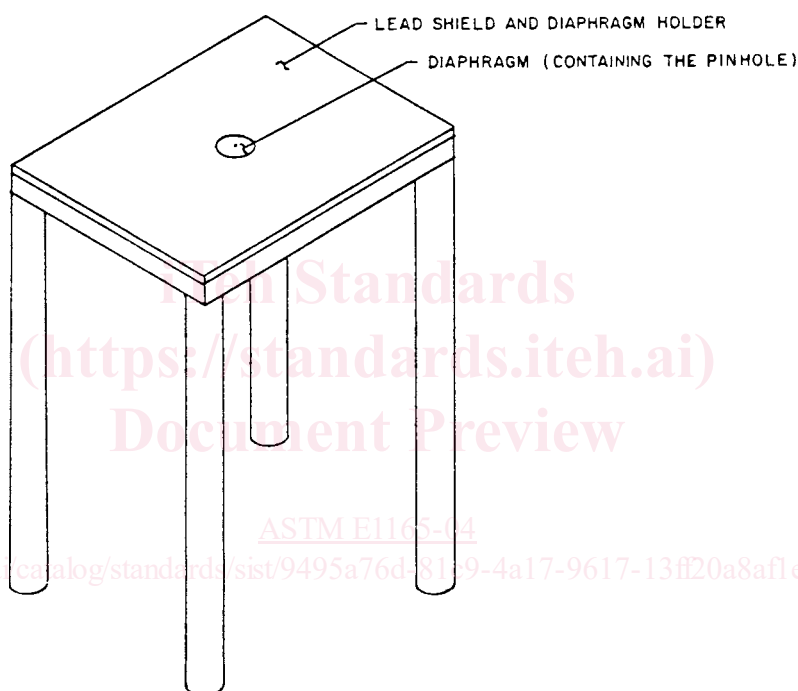

FIG. 4 Pinhole Camera (Typical)

TABLE 2 Image Enlargement Factors

Nominal Focal Spot Size, mm (in.)	Enlargement Factor	Distance Between Focal Spot and Pinhole (FHD), cm (in.) ^A
0.3 to 1.2 (0.011 to 0.046) incl	3×	22.9 (9)
>1.2 to 2.5 (0.046 to 0.097) incl	2×	30.5(12)
>2.5 (0.097)	1×	45.7(18)

^AWhen using a technique that entails the use of enlargement factors and a 91.44 cm (36 in.) focal spot to film distance (FFD) is not possible (see 6.1), the distance between the focal spot and the pinhole (FHD) shall be adjusted to suit the actual focal spot to film distance (FFD) used (for example, if a 61 cm (24 in.) FFD is used, the FHD shall be 15.25 cm (6 in.) for 3× enlargement, 20.32 cm (8 in.) for 2× enlargement, and the like).