**Earth-moving machinery — Hydraulic
excavators — Lift capacity**

Engins de terrassement — Pelles hydrauliques — Capacité de levage

iTeh STANDARD PREVIEW
(standards.iteh.ai)

[ISO 10567:2007](https://standards.iteh.ai/catalog/standards/sist/61fff68e-6859-499d-8eda-be4e5563bdb1/iso-10567-2007)

<https://standards.iteh.ai/catalog/standards/sist/61fff68e-6859-499d-8eda-be4e5563bdb1/iso-10567-2007>



PDF disclaimer

This PDF file may contain embedded typefaces. In accordance with Adobe's licensing policy, this file may be printed or viewed but shall not be edited unless the typefaces which are embedded are licensed to and installed on the computer performing the editing. In downloading this file, parties accept therein the responsibility of not infringing Adobe's licensing policy. The ISO Central Secretariat accepts no liability in this area.

Adobe is a trademark of Adobe Systems Incorporated.

Details of the software products used to create this PDF file can be found in the General Info relative to the file; the PDF-creation parameters were optimized for printing. Every care has been taken to ensure that the file is suitable for use by ISO member bodies. In the unlikely event that a problem relating to it is found, please inform the Central Secretariat at the address given below.

iTeh STANDARD PREVIEW
(standards.iteh.ai)

[ISO 10567:2007](https://standards.iteh.ai/catalog/standards/sist/61fff68e-6859-499d-8eda-be4e5563bdb1/iso-10567-2007)

<https://standards.iteh.ai/catalog/standards/sist/61fff68e-6859-499d-8eda-be4e5563bdb1/iso-10567-2007>



COPYRIGHT PROTECTED DOCUMENT

© ISO 2007

All rights reserved. Unless otherwise specified, no part of this publication may be reproduced or utilized in any form or by any means, electronic or mechanical, including photocopying and microfilm, without permission in writing from either ISO at the address below or ISO's member body in the country of the requester.

ISO copyright office
Case postale 56 • CH-1211 Geneva 20
Tel. + 41 22 749 01 11
Fax + 41 22 749 09 47
E-mail copyright@iso.org
Web www.iso.org

Published in Switzerland

Contents

	Page
1 Scope	1
2 Normative references	1
3 Terms and definitions	1
4 Calculations	4
5 Verification testing	8
6 Validation of calculated values	13
7 Rated lift capacity chart	13
Annex A (informative) Examples of typical rated lift capacity charts	14
Bibliography	16

iTeh STANDARD PREVIEW (standards.iteh.ai)

[ISO 10567:2007](https://standards.iteh.ai/catalog/standards/sist/61fff68e-6859-499d-8eda-be4e5563bdb1/iso-10567-2007)

<https://standards.iteh.ai/catalog/standards/sist/61fff68e-6859-499d-8eda-be4e5563bdb1/iso-10567-2007>

Foreword

ISO (the International Organization for Standardization) is a worldwide federation of national standards bodies (ISO member bodies). The work of preparing International Standards is normally carried out through ISO technical committees. Each member body interested in a subject for which a technical committee has been established has the right to be represented on that committee. International organizations, governmental and non-governmental, in liaison with ISO, also take part in the work. ISO collaborates closely with the International Electrotechnical Commission (IEC) on all matters of electrotechnical standardization.

International Standards are drafted in accordance with the rules given in the ISO/IEC Directives, Part 2.

The main task of technical committees is to prepare International Standards. Draft International Standards adopted by the technical committees are circulated to the member bodies for voting. Publication as an International Standard requires approval by at least 75 % of the member bodies casting a vote.

Attention is drawn to the possibility that some of the elements of this document may be the subject of patent rights. ISO shall not be held responsible for identifying any or all such patent rights.

ISO 10567 was prepared by Technical Committee ISO/TC 127, *Earth-moving machinery*, Subcommittee SC 1, *Test methods relating to machine performance*.

This second edition cancels and replaces the first edition (ISO 10567:1992), which has been technically revised.

iTeh STANDARD PREVIEW
(standards.iteh.ai)

[ISO 10567:2007](https://standards.iteh.ai/catalog/standards/sist/61fff68e-6859-499d-8eda-be4e5563bdb1/iso-10567-2007)

<https://standards.iteh.ai/catalog/standards/sist/61fff68e-6859-499d-8eda-be4e5563bdb1/iso-10567-2007>

Earth-moving machinery — Hydraulic excavators — Lift capacity

1 Scope

This International Standard provides a uniform method for calculating the lift capacity of hydraulic excavators and specifies a procedure for verifying the calculations. It is applicable to the limits of both hydraulic lift capacity and machine-tipping, and establishes the rated lift capacity for hydraulic excavators as defined in ISO 7135.

2 Normative references

The following referenced documents are indispensable for the application of this document. For dated references, only the edition cited applies. For undated references, the latest edition of the referenced document (including any amendments) applies.

ISO 7135, *Earth-moving machinery — Hydraulic excavators — Terminology and commercial specifications*

ISO 9248, *Earth-moving machinery — Units for dimensions, performance and capacities, and their measurement accuracies*

3 Terms and definitions

For the purposes of this document, the following terms and definitions apply.

3.1

load

external mass, including the mass of the attached equipment and attachment if applicable, applied at the lift point

3.2

lift point

LP

⟨condition 1⟩ location on the bucket or the attachment bracket, as specified by the manufacturer, to which a load may be attached

See Figure 1 a).

NOTE For attaching the bucket or attachment bracket load, the bucket cylinder need not be fully extended.

3.3

lift point

LP

⟨condition 2⟩ centreline of the bucket pivot mounting pin on the arm

See Figure 1 b).

3.4

lift-point height

LPH

vertical distance from the ground reference plane (GRP) to the lift point

See Figure 1.

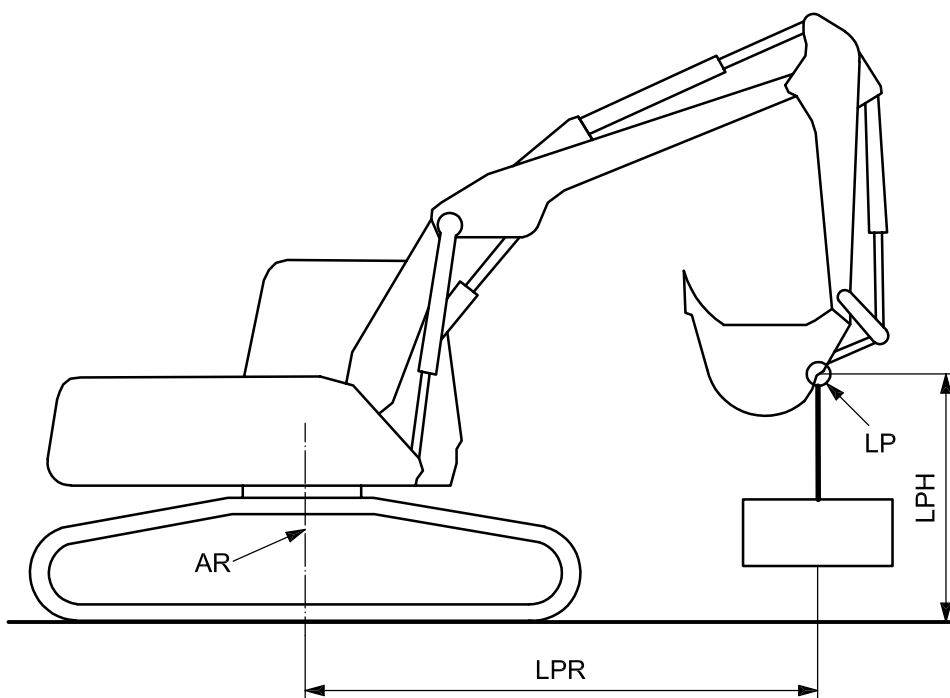

a) Condition 1

iTeh STANDARD PREVIEW
(standards.iteh.ai)

ISO 10567:2007

<https://standards.iteh.ai/catalog/standards/sist/61ff68e-6859-499d-8eda-be4e7263bdb1/iso-10567-2007>

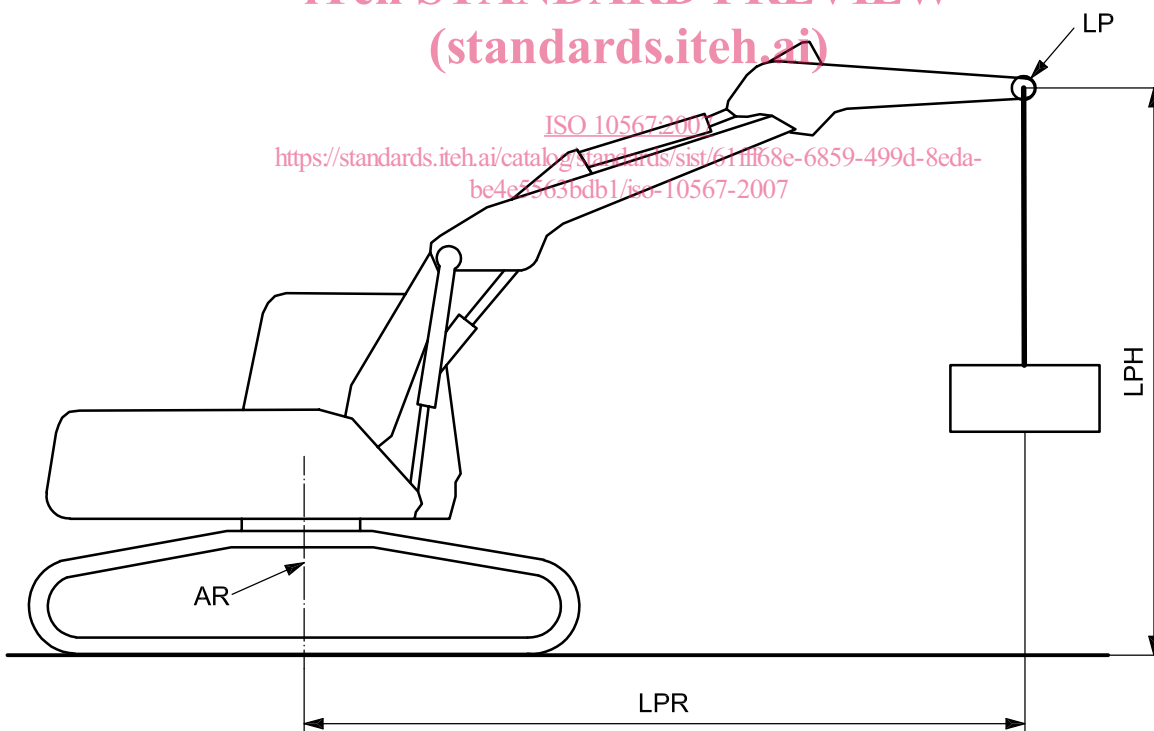

b) Condition 2

Figure 1 — Lift point

Key

- AR axis of rotation
- LP lift point
- LPH lift-point height
- LPR lift-point radius

3.5**lift-point radius****LPR**

horizontal distance from the axis of rotation to the vertical hoist line or tackle

See Figure 1.

3.6**balance point**

moment acting to overturn the machine with a specific load and lift-point radius, which is equal to the moment of the machine available to resist overturning

3.7**tipping load**

static load at the balance point

3.8**rated tipping load**

75 % of the tipping load

3.9**working circuit pressure**

nominal hydraulic pressure applied to the specific circuit by the pump(s)

3.10**holding circuit pressure**

maximum static hydraulic pressure in a specific circuit, limited by a relief valve at a flow no greater than 10 % of rated circuit flow

3.11**hydraulic lift capacity**

load that can be lifted from the lift point by the boom, arm or bucket cylinders with the excavator physically restrained from tipping

3.11.1**boom cylinder hydraulic lift capacity**

load that can be lifted by applying working circuit pressure to the boom cylinder(s) without exceeding holding circuit pressure in any other circuit

3.11.2**arm cylinder hydraulic lift capacity**

load that can be lifted by applying working circuit pressure to the arm cylinder(s) without exceeding the holding circuit pressure in any other circuit

3.11.3**bucket cylinder hydraulic lift capacity**

load that can be lifted by applying working circuit pressure to bucket cylinder without exceeding the holding circuit pressure in any other circuit

3.12**rated hydraulic lift capacity**

87 % of the smaller of boom or arm hydraulic lift capacity at specific lift-point positions

3.13**rated lift capacity**

smaller of either the rated tipping load or the rated hydraulic lift capacity

3.14**maximum radius**

maximum lift-point radius at a given lift-point height

3.15

maximum radius rated lift capacity

rated lift capacity at the maximum radius

3.16

adjustable intermediate boom

hydraulically adjustable intermediate boom consisting of stub, intermediate boom and hydraulic cylinder(s)

3.17

minimum radius

minimum lift-point radius at a given lift-point height

3.18

minimum radius lift capacity

rated lift capacity at the minimum radius determined in the same manner as the rated lift capacity

4 Calculations

4.1 Tipping load calculations

4.1.1 General

Tipping load calculations shall be made at each grid line intersection of a 0,5 m, 1 m or 2 m vertically and horizontally spaced grid placed over the excavator's working range. The origin of the grid shall be at the intersection of the ground reference plane (GRP) and the axis of rotation. The tipping load calculations shall be made to determine the load that can be lifted with the machine at its balance point (3.6). Tipping load calculations shall be made over the side and over the end of the excavator undercarriage. When the undercarriage is not symmetrical about the axis of rotation from front to rear, the tipping load calculations shall be made in the least favourable position. Maximum and minimum radii lift capacity positions may be calculated for each horizontal grid line at the excavator manufacturer's discretion.

4.1.2 Machine configuration for calculations

4.1.2.1 The tipping loads shall be calculated with the machine on a firm, level supporting surface.

4.1.2.2 Tipping load calculations are not to be published for equipment positions in which a vertical line projected downward from the lift point would pass through the bucket.

4.1.2.3 The operating mass shall consist of the base machine and equipment, with empty attachment or attachment bracket if the lift point as defined in 3.2 is specified by the manufacturer, and with the operator (75 kg), full fuel tank and with all fluid systems at the levels specified by the manufacturer.

4.1.2.4 Tipping loads for machines equipped with an adjustable intermediate boom shall be calculated with the intermediate boom positioned at maximum length. See Figure 1.

4.1.2.5 If the equipment has additional adjustable positions, calculations shall be made in the most unfavourable position.

4.1.2.6 For tipping load calculations when a bucket is installed, the bucket attitude shall have a vertical line projected from the lift point, tangent, or as near tangent as the bucket linkage allows, to the back side of the bucket. When the bucket linkage does not allow the load line to be tangent, the line may

- a) hang free of the back of the bucket, regardless of the bucket cylinder extension, with the load line adequately retained to the lift point (see Figure 1 a), or
- b) wrap smoothly around the back of the bucket, regardless of the bucket cylinder extension, without allowing the load line to come in contact with any sharp projection on the back of the bucket or edge of the bucket lip.

4.1.3 Calculations for balance point for end tipping line

4.1.3.1 The tipping line used for balance point calculations over the front/rear of machines with track-type undercarriage shall be a line connecting the centreline of support idlers or sprockets (see Figure 2). The equipment shall be positioned over the front/rear in the least stable position for these calculations.

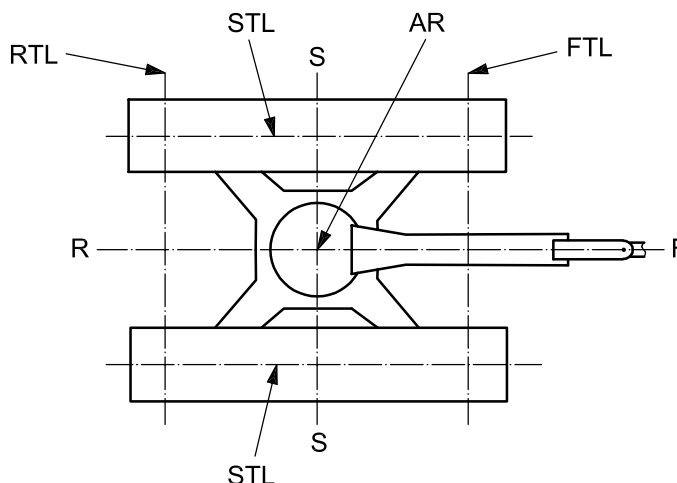

Key

F	front
R	rear
S	side
AR	axis of rotation
FTL	front tipping line
RTL	rear tipping line
STL	side tipping line

iTeh STANDARD PREVIEW
(standards.iteh.ai)

[ISO 10567:2007](https://standards.iteh.ai/catalog/standards/sist/61fff68e-6859-499d-8eda-be4e5563bdb1/iso-10567-2007)

<https://standards.iteh.ai/catalog/standards/sist/61fff68e-6859-499d-8eda-be4e5563bdb1/iso-10567-2007>

Figure 2 — Tipping conditions for track-type undercarriage

4.1.3.2 The tipping line to be used for balance point calculations over the front/rear of machines with a rubber-tyred undercarriage shall be the axle centreline, the bogie axle centreline, or a line connecting the outrigger pads as shown in Figure 3.

4.1.3.3 The tipping line for pivoted outrigger pads shall be a line at the GRP, connecting the point on the pads directly below the centreline of the pivot. For rigid outrigger pads, the tipping line shall be a line connecting the centroid of the contact area between the pads and the GRP. See Figure 3 a).

4.1.3.4 A blade, properly attached to the machine and capable of supporting the machine as an outrigger, may be considered an outrigger. The location of the blade tipping line shall be a line at the GRP where the blade contacts that plane. See Figure 3 b).

4.1.3.5 For machines equipped with outriggers and/or blade, calculations shall be made both without the outriggers and/or blade applied and with the outriggers and/or blade applied in their most favourable position.

4.1.4 Calculations for balance point for side tipping line

4.1.4.1 The tipping line used for side-tipping balance point calculations on machines with track-type undercarriages shall be defined by the pivot points between support rollers and track elements (such as links or guides) as shown in Figures 2 and 4.

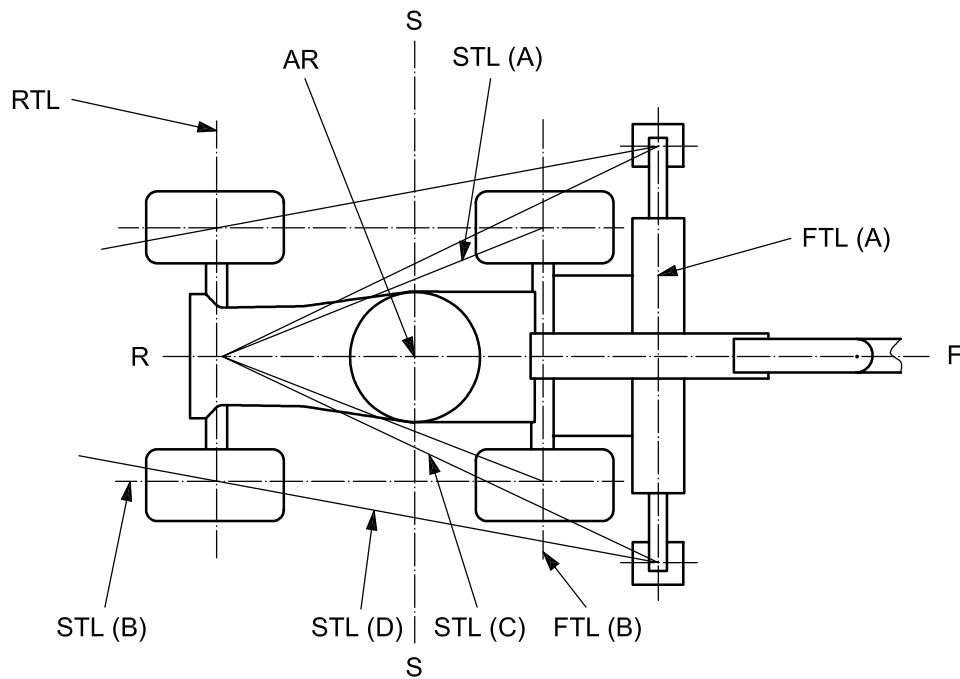

Key

- F front
- R rear
- S side
- AR axis of rotation
- FTL (A) front tipping line with outriggers
- FTL (B) front tipping line at axle centreline
- RTL rear tipping line at axle centreline
- STL (A) side tipping line with oscillating axle
- STL (B) side tipping line without blade, without outriggers and with non-oscillating axle
- STL (C) side tipping line with outriggers or blade with oscillating axle
- STL (D) side tipping line with outriggers and non-oscillating axle

iTeh STANDARD PREVIEW
(standards.iteh.ai)

[ISO 10567:2007](https://standards.iteh.ai/catalog/standards/sist/61fff68e-6859-499d-8eda-be4e5563bdb1/iso-10567-2007)

<https://standards.iteh.ai/catalog/standards/sist/61fff68e-6859-499d-8eda-be4e5563bdb1/iso-10567-2007>

a) Undercarriage with outriggers

Figure 3 — Tipping conditions for rubber-tyred undercarriage

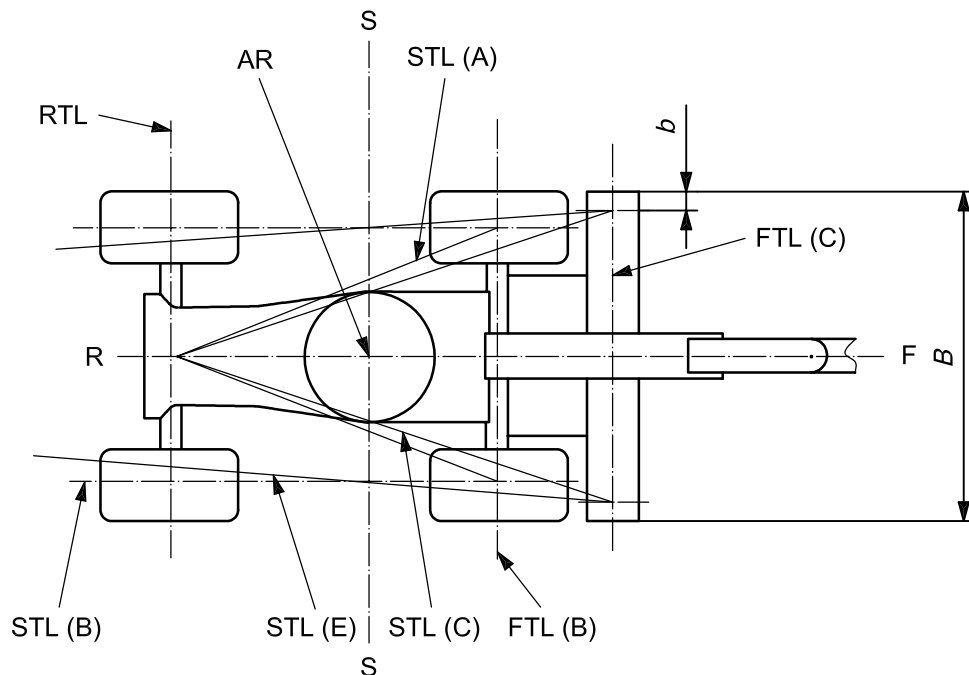
**Key**

F	front
R	rear
S	side
AR	axis of rotation
FTL (B)	front tipping line at axle centreline
FTL (C)	front tipping line with blade
RTL	rear tipping line at axle centreline
STL (A)	side tipping line with oscillating axle
STL (B)	side tipping line without blade, without outriggers and with non-oscillating axle
STL (C)	side tipping line with outriggers or blade with oscillating axle
STL (E)	side tipping line with blade and non-oscillating axle
<i>B</i>	overall length of blade in contact with GRP
<i>b</i>	$= 0,025 \times B$

iTeh STANDARD PREVIEW
(standards.iteh.ai)

<https://standards.iteh.ai/catalog/standards/sist/61fff68e-6859-499d-8eda-be4e5563bdb1/iso-10567-2007>

b) Undercarriage with blade**Figure 3 — Tipping conditions for rubber-tyred undercarriage (continued)**

4.1.4.2 The tipping line to be used for calculations for the balance point of machines with a rubber-tyred undercarriage with blocked or non-oscillating axles shall be a line connecting the centre of contact of the tyres (midpoint between dual tyres) on the same side of the machine, at the GRP, see Figures 3 and 4.

4.1.4.3 The tipping line for an excavator with an oscillating axle shall be a line through the axle pivot point and one other rigid support point (see Figure 3).

4.1.4.4 If ratings are based upon a blocked or non-oscillating axle, this condition shall be clearly defined on the load rating charts and diagrams.

4.1.4.5 When outriggers are used, the position of the tipping line shall be as specified in 4.1.3.2 and 4.1.3.3.

4.1.4.6 When the blade is used, the side tipping line shall be as specified in 4.1.3.4.