



Standard Test Method for Measurement of Lubricity of Aviation Turbine Fuels by the Ball-on-Cylinder Lubricity Evaluator (BOCLE)¹

This standard is issued under the fixed designation D 5001; the number immediately following the designation indicates the year of original adoption or, in the case of revision, the year of last revision. A number in parentheses indicates the year of last reapproval. A superscript epsilon (ϵ) indicates an editorial change since the last revision or reapproval.

1. Scope

1.1 This test method covers assessment of the wear aspects of the boundary lubrication properties of aviation turbine fuels on rubbing steel surfaces.

1.2 The values stated in SI units are to be regarded as the standard.

1.3 *This standard does not purport to address the safety concerns, if any, associated with its use. It is the responsibility of the user of this standard to establish appropriate safety and health practices and determine the applicability of regulatory limitations prior to use.* Specific warning statements are given in Section 7 and Annex A1.

2. Referenced Documents

2.1 ASTM Standards:²

D 329 Specification for Acetone

D 770 Specification for Isopropyl Alcohol

D 1016 Test Method for Purity of Hydrocarbons from Freezing Points

D 4306 Practice for Aviation Fuel Sample Containers for Tests Affected by Trace Contamination

2.2 Military Specification:

MIL-I-25017, Inhibitor, Corrosion/Lubricity Improver, Fuel Soluble³

2.3 American Iron and Steel Institute Standard:

AISI E-52100 Chromium Alloy Steel⁴

2.4 American National Standards Institute Standard:

ANSI B3.12, Metal Balls⁵

2.5 *Society of Automotive Engineers Standard:*
SAE 8720 Steel⁶

3. Terminology

3.1 Definitions of Terms Specific to This Standard:

3.1.1 *cylinder*—the test ring and mandrel assembly.

3.1.2 *lubricity*—a general term used to describe the boundary lubrication properties of a fluid. In this test method, the lubricity of a fluid is defined in terms of a wear scar, in millimetres, produced on a stationary ball from contact with the fluid-wetted rotating cylinder operating under closely defined and controlled conditions.

4. Summary of Test Method

4.1 The fluid under test is placed in a test reservoir in which atmospheric air is maintained at 10 % relative humidity. A non-rotating steel ball is held in a vertically mounted chuck and forced against an axially mounted steel ring with an applied load. The test cylinder is rotated at a fixed speed while being partially immersed in the fluid reservoir. This maintains the cylinder in a wet condition and continuously transports the test fluid to the ball/cylinder interface. The wear scar generated on the test ball is a measure of the fluid lubricating properties.

5. Significance and Use

5.1 Wear due to excessive friction resulting in shortened life of engine components such as fuel pumps and fuel controls has sometimes been ascribed to lack of lubricity in an aviation fuel.

5.2 The relationship of test results to aviation fuel system component distress due to wear has been demonstrated for some fuel/hardware combinations where boundary lubrication is a factor in the operation of the component.

5.3 The wear scar generated in the ball-on-cylinder lubricity evaluator (BOCLE) test is sensitive to contamination of the fluids and test materials, the presence of oxygen and water in the atmosphere, and the temperature of the test. Lubricity

¹ This test method is under the jurisdiction of ASTM Committee D02 on Petroleum Products and Lubricants and is the direct responsibility of Subcommittee D02.J0 on Aviation Fuels.

Current edition approved Dec. 1, 2003. Published January 2004. Originally approved in 1989. Last previous edition approved in 2000 as D 5001–90a (2000) ^{ϵ 1}.

This test method was developed by the Coordinating Research Council and is a part of their report No. 560.

² For referenced ASTM standards, visit the ASTM website, www.astm.org, or contact ASTM Customer Service at service@astm.org. For *Annual Book of ASTM Standards* volume information, refer to the standard's Document Summary page on the ASTM website.

³ Available from Standardization Documents Order Desk, DODSSP, Bldg. 4, Section D, 700 Robbins Ave., Philadelphia, PA 19111-5098

⁴ Available from American Iron and Steel Institute (AISI), 1101 17th St., NW, Suite 1300, Washington, DC 20036.

⁵ Available from American National Standards Institute (ANSI), 25 W. 43rd St., 4th Floor, New York, NY 10036.

⁶ Available from Society of Automotive Engineers (SAE), 400 Commonwealth Dr., Warrendale, PA 15096-0001.



FIG. 1 Ball-on-Cylinder Lubricity Evaluator

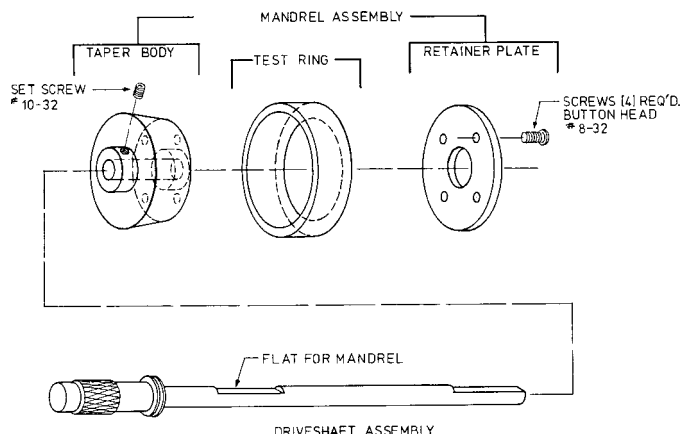

FIG. 2 Ring Mandrel Assembly

TABLE 1 Standard Operating Conditions

Fluid Volume	50 ± 1.0 mL
Fluid Temperature	25 ± 1°C
Conditioned Air	10 ± 0.2 % relative humidity at 25 ± 1°C
	Fluid pretreatment 0.50 L/min flowing through and 3.3 L/min over the fluid for 15 min.
	Fluid test conditions 3.8 L/min flowing over the fluid.
Applied Load	1000 g (500 g weight)
Cylinder Rotational Speed	240 ± 1 r/min
Test Duration	30 ± 0.1 min

6.3.1 *Glass Slide Micrometer*, with a scale ruled in 0.01 mm divisions.^{8,9}

6.4 *Cleaning Bath*—Ultrasonic seamless stainless steel tank with a capacity of 1.9 L (½ gal) and a cleaning power of 40 W.

7. Reagents and Materials

7.1 *Test Ring*, of SAE 8720 steel, having a Rockwell hardness “C” scale, (HRC) number of 58 to 62 and a surface finish of 0.56 to 0.71 μm (22 to 28 μin.) root mean square. The dimensions are given in Fig. 3.^{9,10}

7.2 *Mandrel*, a 10° tapered short cylindrical section used for holding test ring.^{9,11} See Fig. 2.

7.3 *Test Ball*, chrome alloy steel, made from AISI standard steel No. E-52100, with a diameter of 12.7 mm (0.5 in.) grade 5 to 10 EP finish. The balls are described in ANSI Specifications B 3.12. The extra-polish finish is not described in that specification. The HRC shall be 64 to 66, a closer limit than is found in the ANSI requirement.^{9,12}

measurements are also sensitive to trace materials acquired during sampling and storage. Containers specified in Practice D 4306 shall be used.

5.4 The BOCLE test method may not directly reflect operating conditions of engine hardware. For example, some fuels that contain a high content of certain sulfur compounds may give anomalous test results.

6. Apparatus

6.1 *Ball-On-Cylinder Lubricity Evaluator (BOCLE)*, illustrated in Fig. 1 and Fig. 2. The test requirements are listed in Table 1.⁷

6.2 *Constant Temperature Bath-Circulator*, capable of maintaining the fluid sample at 25 ± 1°C when circulating coolant through the base of the sample reservoir.

6.3 *Microscope*, capable of 100× magnification in graduations of 0.1 mm and incremented in divisions of 0.01 mm.

⁷ BOCLE units, BOC 100, made by InterAv, Inc., P.O. Box 792228, San Antonio, TX 78279 have been found satisfactory. Other units built to the drawings available from ASTM, 100 Barr Harbor Drive, West Conshohocken, PA, meeting the test requirements of Table 1 in accordance with the procedure of 3.2 of Guidelines for Equipment Supply, Listing, and Replacement in ASTM Committee D02 methods and practices are considered acceptable. These units can have different operating procedures.

⁸ The sole source of supply of the apparatus known to the committee at this time is Catalog No. 31-16-99 from Bausch and Lomb, Inc. A certificate of traceability from the National Institute of Standards and Technology is available.

⁹ If you are aware of alternative suppliers, please provide this information to ASTM International Headquarters. Your comments will receive careful consideration at a meeting of the responsible technical committee¹, which you may attend.

¹⁰ The sole source of supply of the apparatus known to the committee at this time is Test Rings, Part No. F25061 from Falex Corp., 2055 Comprehensive Drive, Aurora, IL 60505.

¹¹ Mandrel, part No. M-O from Falex Corp., or P/N BOC-2101 from InterAv, Inc. P.O. Box 792228, San Antonio, TX 78279, have been found satisfactory.

¹² The sole source of supply of the apparatus known to the committee at this time is Test Balls, SKF Swedish, part No. 310995A, RB 12.7, grade 5 to 10 EP Finish, AISI 52100 Alloy from SKF Industries, Component Systems, 1690 East Race Street, Allentown, PA 90653.

INCH EQUIVALENT	
mm	IN.
13.00	0.512
13.11	0.516
38.94	1.533
49.10	1.933
49.25	1.939

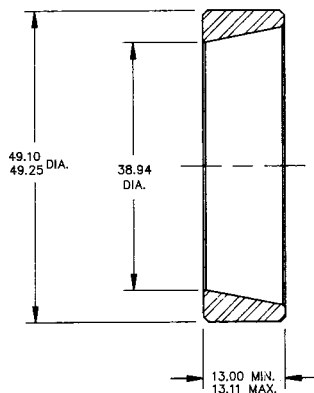

MATERIAL: STEEL SAE #8720 SPECIAL MODIFIED
 HARDNESS: 58 - 62 Rc.
 FINISH: 22 - 28 RMS.
 DIMENSIONS: mm

FIG. 3 BOCLE Test Ring

7.4 *Compressed Air* (**Warning**—Compressed gas under high pressure. Use with extreme caution in the presence of combustible material, since the autoignition temperatures of most organic compounds in air are drastically reduced at elevated pressures. See A1.1.), containing less than 0.1 ppm hydrocarbons and 50 ppm water.

7.5 *Desiccator*, containing a non-indicating drying agent, capable of storing test rings, balls, and hardware.

7.6 *Gloves*, clean, lint-free, cotton, disposable.

7.7 *Wiper*, wiping tissue, light duty, lint free, hydrocarbon free, disposable.

7.8 *Isooctane* (**Warning**—Extremely flammable. Harmful if inhaled. Vapors may cause flash fires. See A1.2.), conforming to Test Method D 1016, 95 % purity minimum, 2,2,4-trimethylpentane.

7.9 *Isopropyl Alcohol* (**Warning**—Flammable. See A1.3.), conforming to Specification D 770.

7.10 *Acetone* (**Warning**—Extremely flammable. Vapors may cause flash fire. See A1.4), conforming to Specification D 329.

7.11 *Reference Fluids*:^{9,13}

7.11.1 *Fluid A*—A mixture shall contain 30 mg/kg of a specific fuel soluble corrosion inhibitor/lubricity improver conforming to MIL-I-25017^{9,14} (**Warning**—Flammable. Vapor harmful. See A1.5.), in fluid B^{9,15} (**Warning**—Flammable. Vapor harmful. See A1.5.).

7.11.2 *Fluid B*—Shall be a narrow-cut isoparaffinic solvent (**Warning**—Flammable. Vapor harmful. See A1.5.).^{9,15}

¹³ The sole source of supply of the apparatus known to the committee at this time is Reference Fluids A and B available in Kit form as part No. RF-930900 from InterAv Inc., P.O. Box 792228, San Antonio, TX 78279.

¹⁴ The sole source of supply of the additive known to the committee at this time is DCI-4A, manufactured by E. I. DuPont de Nemours and Company, 1007 Market Street, Wilmington, DE 19898.

¹⁵ The sole source of supply of the solvent known to the committee at this time is ISOPAR M, manufactured by the Exxon Company, USA, P.O. Box 2180, Houston, TX 77001.

7.11.3 The reference fluid shall be stored in epoxy lined containers or borosilicate glass bottles. Borosilicate glass bottles shall be stored in a dark area with aluminum foil lined insert caps.

8. Preparation of Apparatus

8.1 *Cleaning of Apparatus and Test Components:*

8.1.1 *Test Rings, as Received:*

8.1.1.1 The test rings shall be partially stripped of any wax-like protective coatings by manually rubbing them with rags or paper towels saturated with *isooctane*.

8.1.1.2 Place partially cleaned rings in a clean 500 mL beaker. Transfer a sufficient volume of a 1 to 1 mixture of *isooctane* and isopropyl alcohol to the beaker such that the test rings are completely covered.)

8.1.1.3 Place beaker in ultrasonic cleaner and turn on for 15 min.

8.1.1.4 Remove test rings and repeat ultrasonic cleaning cycle of 8.1.1.3 with a clean beaker and fresh solvents.

8.1.1.5 Handle all clean test rings with clean forceps or disposable gloves. Remove test rings from beaker and rinse with *isooctane*, dry, and rinse with acetone.

NOTE 1—Drying operations can be accomplished using a compressed air (7.4) jet at 140 to 210 kPa (20 to 30 psi) pressure.

8.1.1.6 Dry and store in a desiccator.

8.1.2 *Test Balls, as Received.*

8.1.2.1 Place balls in 300 mL beaker. Transfer a sufficient volume of a 1 to 1 mixture of *isooctane* and isopropyl alcohol to the beaker such that the test balls are completely covered by the cleaning solvent.

NOTE 2—Approximately a five-day supply can be processed at one time.

8.1.2.2 Place beaker in ultrasonic cleaner and turn on for 15 min.

8.1.2.3 Repeat the cleaning cycle of 8.1.2.2 with a clean beaker and fresh solvent.

8.1.2.4 Remove and rinse with *isooctane*, dry, and rinse with acetone.

8.1.2.5 Dry and store in a desiccator.

8.1.3 *Reservoir, Reservoir Cover, Ball Chuck, Ball Lock Ring, and Ring Mandrel Assembly Components:*

8.1.3.1 Rinse with *isooctane*.

8.1.3.2 Clean in an ultrasonic cleaner with a 1 to 1 mixture of *isooctane* and isopropyl alcohol for 5 min.

8.1.3.3 Remove and rinse with *isooctane*, dry, and rinse with acetone.

8.1.3.4 Dry and store in a desiccator.

8.1.4 *Hardware:*

8.1.4.1 The hardware and utensils, that is, shaft, wrenches, and tweezers, that come in contact with the test fluid shall be cleaned by washing thoroughly with *isooctane* and wiped with a wiper.

8.1.4.2 Store parts in desiccator when not in use.

8.1.5 *After Test:*

8.1.5.1 Remove reservoir and cylinder.

8.1.5.2 Disassemble components and clean in an ultrasonic cleaner using a 1 to 1 mixture of *isooctane* and isopropyl