



SLOVENSKI STANDARD
SIST EN 693:2001+A1:2009

01-maj-2009

CVXYcj Ub]glfc]!'JUfbcgh!'<]XfUj`] bYghg_Ub]W

Machine tools - Safety - Hydraulic presses

Werkzeugmaschinen - Sicherheit - Hydraulische Pressen

Machines-outils - Sécurité - Presses hydrauliques

iteh STANDARD PREVIEW
(standards.iteh.ai)

Ta slovenski standard je istoveten z: EN 693:2001+A1:2009

[SIST EN 693:2001+A1:2009](https://standards.iteh.ai/catalog/standards/sist/aef1baa1-08b1-4c2d-8d20-ace08b0bd931/sist-en-693-2001a1-2009)

<https://standards.iteh.ai/catalog/standards/sist/aef1baa1-08b1-4c2d-8d20-ace08b0bd931/sist-en-693-2001a1-2009>

ICS:

25.120.10	Kovaški stroji. Stiskalnice. Škarje	Forging equipment. Presses. Shears
-----------	--	---------------------------------------

SIST EN 693:2001+A1:2009

en,fr

iTeh STANDARD PREVIEW
(standards.iteh.ai)

SIST EN 693:2001+A1:2009

<https://standards.iteh.ai/catalog/standards/sist/aef1baa1-08b1-4c2d-8d20-acc08b0bd931/sist-en-693-2001a1-2009>

EUROPEAN STANDARD

EN 693:2001+A1

NORME EUROPÉENNE

EUROPÄISCHE NORM

February 2009

ICS 25.120.10

Supersedes EN 693:2001

English Version

Machine tools - Safety - Hydraulic presses

Machines-outils - Sécurité - Presses hydrauliques

Werkzeugmaschinen - Sicherheit - Hydraulische Pressen

This European Standard was approved by CEN on 20 November 2000 and includes Amendment 1 approved by CEN on 29 December 2008.

CEN members are bound to comply with the CEN/CENELEC Internal Regulations which stipulate the conditions for giving this European Standard the status of a national standard without any alteration. Up-to-date lists and bibliographical references concerning such national standards may be obtained on application to the CEN Management Centre or to any CEN member.

This European Standard exists in three official versions (English, French, German). A version in any other language made by translation under the responsibility of a CEN member into its own language and notified to the CEN Management Centre has the same status as the official versions.

CEN members are the national standards bodies of Austria, Belgium, Bulgaria, Cyprus, Czech Republic, Denmark, Estonia, Finland, France, Germany, Greece, Hungary, Iceland, Ireland, Italy, Latvia, Lithuania, Luxembourg, Malta, Netherlands, Norway, Poland, Portugal, Romania, Slovakia, Slovenia, Spain, Sweden, Switzerland and United Kingdom.

ITIH STANDARD PREVIEW
(standards.iteh.ai)

SIST EN 693:2001+A1:2009
<https://standards.iteh.ai/catalog/standards/sist/aef1baa1-08b1-4c2d-8d20-acc08b0bd931/sist-en-693-2001a1-2009>



EUROPEAN COMMITTEE FOR STANDARDIZATION
COMITÉ EUROPÉEN DE NORMALISATION
EUROPÄISCHES KOMITEE FÜR NORMUNG

Management Centre: Avenue Marnix 17, B-1000 Brussels

Contents

Page

Foreword.....	3
Introduction	4
1 Scope	4
2 Normative references	5
3 Terms and definitions	6
4 List of hazards.....	12
5 Safety requirements and measures	14
5.1 Introduction	14
5.2 Basic design considerations	14
5.3 Mechanical hazards in the tools area	17
5.4 The control and monitoring system.....	21
5.5 Toolsetting, trial strokes, maintenance and lubrication	24
5.6 Mechanical hazards - Other	25
5.7 Slips, trips and falls	26
5.8 Protection against other hazards.....	26
6 Verification of the safety requirements and/or measures	33
7 Information for use	39
7.1 Marking	39
7.2 Instruction handbook	40
Annex A (normative) Calculation of minimum safety distances.....	42
Annex B (normative) The response time of the hydraulic system.....	44
Annex C (informative) Closed tools.....	45
Annex D (informative) Interlocking devices associated with guards	46
Annex E (informative) Electro-sensitive protective equipment (ESPE) using active opto-electronic protective devices (AOPDs).....	49
Annex F (informative) Conditions for noise measurement of hydraulic presses.....	50
Annex G (informative) The connection of the stopping time measurement equipment.....	52
Annex ZA (informative) Relationship between this European Standard and the Essential Requirements of EU Directive 98/37/EC amended by Directive 98/79/EC	53
Annex ZB (informative) Relationship between this European Standard and the Essential Requirements of EU Directive 2006/42/EC	54
Bibliography	55

Foreword

This document (EN 693:2001+A1:2009) has been prepared by Technical Committee CEN/TC 143 "Machine tools - Safety", the secretariat of which is held by SNV.

This European Standard shall be given the status of a national standard, either by publication of an identical text or by endorsement, at the latest by August 2009, and conflicting national standards shall be withdrawn at the latest by December 2009.

This document includes Amendment 1, approved by CEN on 2008-12-29.

This document supersedes EN 693:2001.

The start and finish of text introduced or altered by amendment is indicated in the text by tags \square_{A1} \square_{A1} .

This European Standard has been prepared under a mandate given to CEN by the European Commission and the European Free Trade Association, and supports essential requirements of EU Directive(s).

\square_{A1} For relationship with EU Directive(s), see informative Annexes ZA and ZB, which are integral parts of this document. \square_{A1}

Annexes A and B to this standard are normative, whereas Annexes C to G \square_{A1} , ZA and ZB \square_{A1} are informative.

This standard also contains a bibliography.

According to the CEN/CENELEC Internal Regulations, the national standards organizations of the following countries are bound to implement this European Standard: Austria, Belgium, Bulgaria, Cyprus, Czech Republic, Denmark, Estonia, Finland, France, Germany, Greece, Hungary, Iceland, Ireland, Italy, Latvia, Lithuania, Luxembourg, Malta, Netherlands, Norway, Poland, Portugal, Romania, Slovakia, Slovenia, Spain, Sweden, Switzerland and United Kingdom.

EN 693:2001+A1:2009 (E)**Introduction**

- 0.1** This standard is applicable to hydraulic presses as defined in 3.10.
- 0.2** This standard has been prepared to be a harmonized standard to provide one means of conforming with the essential safety requirements of the "Machinery" Directive and associated EFTA Regulations.
- 0.3** The extent to which hazards are covered is indicated in the scope of this standard. In addition, machinery shall comply as appropriate with EN 292 for hazards which are not covered by this standard.
- 0.4** Complementary guidance is given in the A and B standards to which reference is made in the text (see clause 2). The figures are intended to be examples only and not to give the only interpretation of the text.

1 Scope

1.1 This standard specifies technical safety requirements and measures to be adopted by persons undertaking the design (as defined in 3.11 of EN 292-1:1991), manufacture and supply of hydraulic presses which are intended to work cold metal or material partly of cold metal.

1.2 This standard also covers presses, whose primary intended use is to work cold metal, which are to be used in the same way to work other sheet materials (such as cardboard, plastic, rubber or leather), and metal powder.

1.3 The requirements in this standard take account of intended use, as defined in 3.12 of EN 292-1:1991. This standard presumes access to the press from all directions, deals with the hazards described in clause 4, and specifies the safety measures for both the operator and other exposed persons.

1.4 This standard also applies to ancillary devices which are an integral part of the press. For the safeguarding of integrated manufacturing systems using presses, see also ISO 11161.

1.5 This standard does not cover machines whose principal designed purpose is:

- a) sheet metal cutting by guillotine;
- b) attaching a fastener, e.g. riveting, stapling or stitching;
- c) bending or folding;
- d) straightening;
- e) turret punch pressing;
- f) extruding;
- g) drop forging or drop stamping;
- h) compaction of metal powder;
- i) single purpose punching machines designed exclusively for profiles, e.g. for the construction industry.

1.6 This standard is applicable to machines built after its date of issue.

2 Normative references

This European standard incorporates, by dated or undated reference, provisions from other publications. These normative references are cited at the appropriate places in the text and the publications are listed hereafter. For dated references, subsequent amendments to or revisions of any of these publications apply to this European standard only when incorporated in it by amendment or revision. For undated references, the latest edition of the publication referred to applies (including amendments).

EN 292-1:1991, *Safety of machinery - Basic concepts, general principles for design - Part 1: Basic terminology, methodology.*

EN 292-2:1991, *Safety of machinery - Basic concepts, general principles for design - Part 2: Technical principles and specifications (and Amendment A1:1995).*

EN 294:1992, *Safety of machinery - Safety distances to prevent danger zones being reached by the upper limbs.*

EN 349:1993, *Safety of machinery - Minimum gaps to avoid crushing of parts of the human body.*

EN 418:1992, *Safety of machinery - Emergency stop equipment, functional aspects - Principles for design.*

EN 563:1994, *Safety of machinery - Temperatures of touchable surfaces - Ergonomics data to establish temperature limit values for hot surfaces.*

EN 574:1996, *Safety of machinery - Two-hand control device.*

EN 614-1:1995, *Safety of machinery - Ergonomic design principles - Part 1: Terminology and general principles.*

<https://standards.iteh.ai/catalog/standards/sist/ae1baa1-08b1-4c2d-8d20-ace08b0bd931/sist-en-693-2001a1-2009>

EN 626-1:1994, *Safety of machinery - Reduction of risks to health from hazardous substances emitted by machinery - Part 1: Principles and specifications for machinery manufacturers.*

EN 842:1996, *Safety of machinery - Visual danger signals - General requirements, design and testing.*

EN 894-2:1997, *Safety of machinery - Ergonomics requirements for the design of displays and control actuators - Part 2: Displays.*

EN 894-3:2000, *Safety of machinery - Ergonomics requirements for the design of displays and control actuators - Part 3: Control actuators.*

EN 953:1997, *Safety of machinery - General requirements for the design and construction of guards (fixed, movable).*

EN 954-1:1996, *Safety of machinery - Safety related parts of control systems - Part 1: General principles for design.*

EN 982:1996, *Safety of machinery - Safety requirements for fluid power systems and their components – Hydraulics.*

EN 983:1996, *Safety of machinery - Safety requirements for fluid power systems and their components – Pneumatics.*

EN 999:1998, *Safety of machinery - Approach speed of parts of the body for the positioning of safety devices.*

EN 693:2001+A1:2009 (E)

prEN 1005-2:1993, *Safety of machinery - Human physical performance - Part 2: Manual handling of objects associated to machinery.*

EN 1037:1995, *Safety of machinery - Prevention of unexpected start-up.*

EN 1050:1996, *Safety of machinery - Principles for risk assessment.*

EN 1088:1995, *Safety of machinery - Interlocking devices associated with guards - Principles for design and selection.*

EN 1127-1:1997, *Safety of machinery - Fire and explosions - Part 1: Explosion prevention and protection.*

EN 1299:1997, *Vibration isolation of machines - Information for the application or source isolation.*

EN ISO 3746:1995, *Acoustics - Determination of sound power levels of noise sources using sound pressure - Survey method using an enveloping measurement surface over a reflecting plane (ISO 3746:1995).*

EN ISO 4871:1996, *Acoustics - Declaration and verification of noise emission values of machinery and equipment (ISO 4871:1996)*

ISO 11161:1994, *Industrial automation systems - Safety of integrated manufacturing systems – Basic requirements.*

EN ISO 11202:1995, *Acoustics - Noise emitted by machinery and equipment - Measurement of emission sound pressure levels at a work station and at other specified positions – Survey method in situ (ISO 11202:1995).*

ISO/TR 11688-1:1995, *Acoustics - Recommended practice for the design of low-noise machinery and equipment - Part 1: Planning.*

EN 60204-1:1997, *Safety of machinery - Electrical equipment of machines - Part 1: General requirements (IEC 204-1:1992, modified).*

EN 61310-2:1995, *Safety of machinery - Indication, marking and actuation - Part 2: Requirements for marking (IEC 1310-2:1995).*

EN 61496-1:1997, *Safety of machinery - Electrosensitive protective equipment - Part 1: General requirements and tests (IEC 61496-1:1997).*

prEN 61496-2:1997, *Safety of machinery - Electrosensitive protective equipment - Part 2: Particular requirements for equipment using active opto-electronic protective devices (IEC 61496-2:1997).*

3 Terms and definitions

For the purposes of this standard, the following terms and definitions apply. Further terms and definitions are provided in relevant A and B standards and in annex A of EN 292-2:1991/A1:1995.

3.1 ancillary device
any device intended for use with the press tools and integrated with the press, e.g. devices for lubrication, feed and ejection.

3.2 cycle – automatic
operating mode where the slide/ram repeats continuously or intermittently, all functions achieved without manual intervention into the danger zone after initiation.

3.3**cycle – operating**

movement of the slide/ram from the cycle start position (normally the top dead centre) to the bottom dead centre and back to the cycle stop position (normally the top dead centre). The operating cycle includes all operations carried out during this movement.

3.4**cycle – single**

operating mode where each operating cycle of the slide/ram has to be positively actuated by the operator.

3.5**dead centres**

points at which the tool, during its travel, is

- either nearest/closest to the die (generally it corresponds to the end of the closing stroke), known as the bottom dead centre (BDC),
- or furthest from the die (generally it corresponds to the end of the opening stroke), known as the top dead centre (TDC).

3.6**die**

fixed part of the tools used in a press.

3.7**die cushion**

accessory for a die which accumulates and releases, or absorbs, force as required in some press operations.

3.8**early opening interlocking guard**

guard associated with an interlocking device which, if opened when any dangerous movement in the tools area has ceased, does not interrupt the operating cycle.

3.9**guard locking device**

mechanical device to maintain an interlocking guard gate in the closed and locked position until the risk of injury from the hazardous machine functions has passed.

3.10**hydraulic press**

machine designed or intended to transmit energy by linear movement between closing tools by hydraulic means for the purpose of the working (e.g. forming or shaping) of cold metal or material partly of cold metal between the tools. Such energy is produced by the effects of hydrostatic pressure (see figures 1 and 2).

3.11**limited movement control device; inching device**

control device, the actuation of which permits only a limited amount of travel of a machine element, thus minimizing risk as much as possible; further movement is precluded until there is a subsequent and separate actuation of the control. [3.23.8 of EN 292-1:1991].

3.12**monitoring (M)**

safety function which ensures that a safety measure is initiated if the ability of a component or an element to perform its function is diminished, or if the process conditions are changed in such a way that hazards are generated.

EN 693:2001+A1:2009 (E)**3.13****muting**

temporary automatic suspension of a safety function(s) by safety related parts of the control system during otherwise safe conditions in the operation of a machine [3.7 of EN 954-1:1996].

3.14**overall system stopping performance; overall response time**

time occurring from actuating the protective device to the cessation of hazardous motion, or to the machine assuming a safe condition.

3.15**part detector**

device which detects the workpiece and/or the correct position of the workpiece and which permits or prevents the initiation of the stroke.

3.16**position switch**

switch which is operated by a moving part of the machine when this part reaches or leaves a predetermined position.

3.17**redundancy (R)**

application of more than one device or system, or part of a device or a system, with the objective of ensuring that, in the event of one failing to perform its function, another is available to perform that function. [3.47 of EN 60204-1:1992].

iTeh STANDARD PREVIEW
(standards.iteh.ai)

3.18**restraint valve**

device which protects against a gravity fall of the slide/ram.

[SIST EN 693:2001+A1:2009](https://standards.iteh.ai/catalog/standards/sist/aef1baa1-08b1-4c2d-8d20-ace08b0bd931/sist-en-693-2001a1-2009)

3.19**single stroke function**

feature used to limit the motion of the tool to one operating cycle (single cycle) even if the stroke initiating means (e.g. a pedal) is held in the operating position.

<https://standards.iteh.ai/catalog/standards/sist/aef1baa1-08b1-4c2d-8d20-ace08b0bd931/sist-en-693-2001a1-2009>

3.20**slide/ram**

main reciprocating press member which holds the tool.

3.21**tool**

moving part of the tools.

3.22**tool protective device**

device which protects the tool against damage by stopping the stroke or by preventing its start.

3.23**tools**

term for the combination of tool and die.

3.24**tools – closed**

tools designed and constructed to be inherently safe (see figure C.1).

3.25**up-stroking press**

vertical press in which the press table moves upwards during the closing stroke (reciprocal to a down-stroking press, see figure D.1).

iTeh STANDARD PREVIEW (standards.iteh.ai)

[SIST EN 693:2001+A1:2009](https://standards.iteh.ai/catalog/standards/sist/aef1baa1-08b1-4c2d-8d20-acc08b0bd931/sist-en-693-2001a1-2009)

<https://standards.iteh.ai/catalog/standards/sist/aef1baa1-08b1-4c2d-8d20-acc08b0bd931/sist-en-693-2001a1-2009>

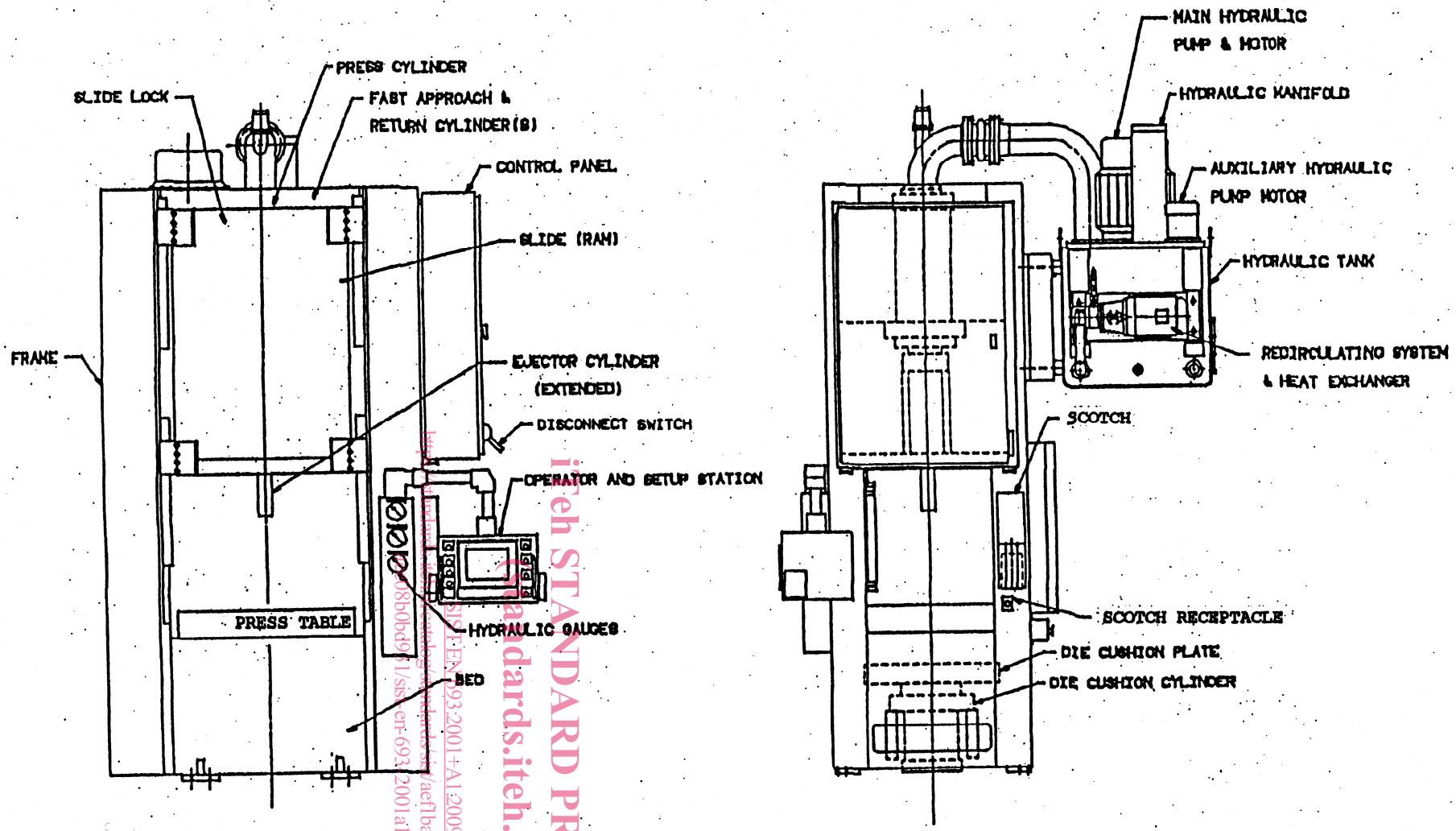

Figure 1 — Example of box frame type hydraulic press (tools area safeguards not shown)

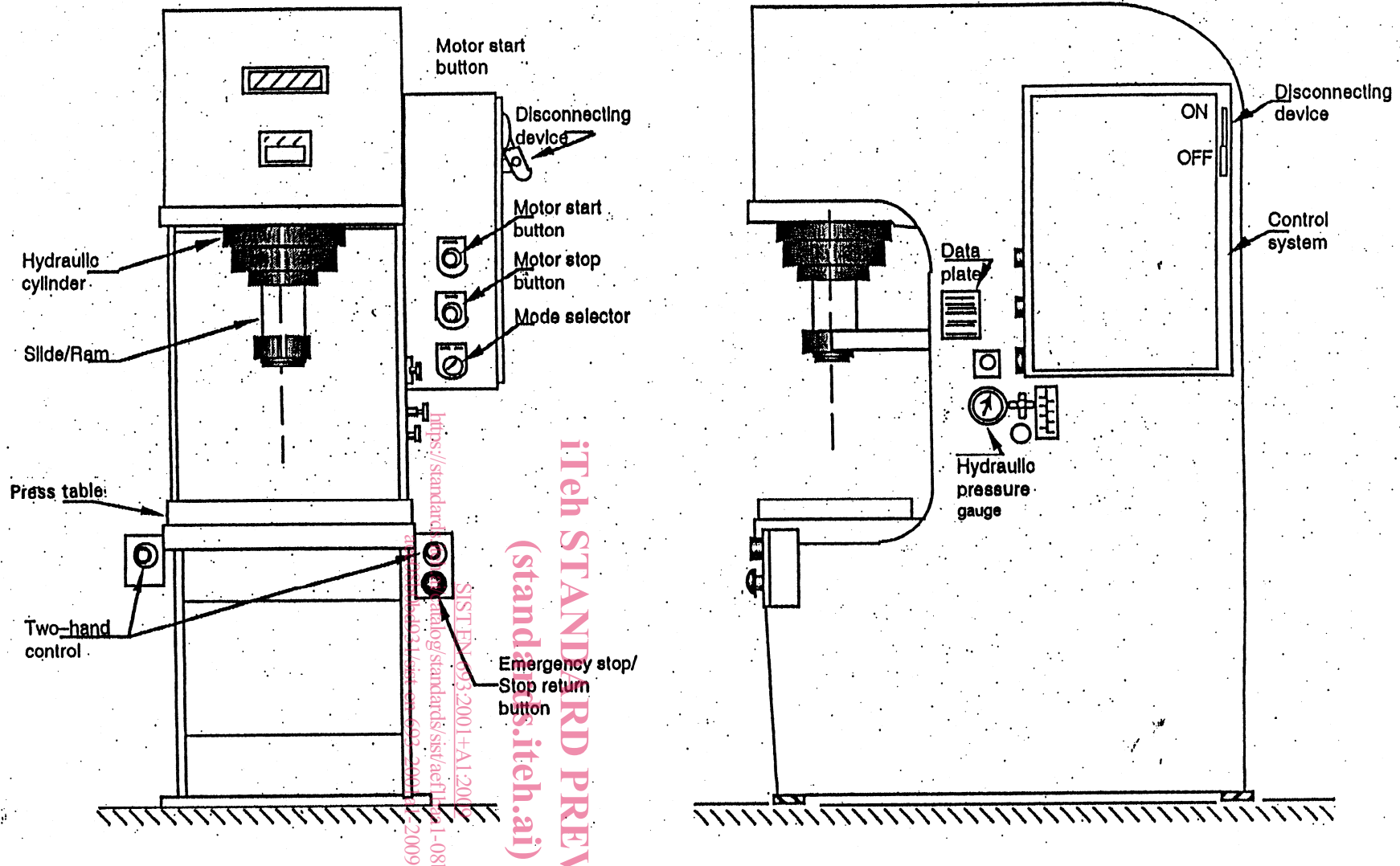

Figure 2 — Example of open front hydraulic press (tools area safeguards not shown)

EN 693:2001+A1:2009 (E)**4 List of hazards**

4.1 The list of hazards contained in table 1 is the result of a risk assessment, carried out as required by EN 1050, for all hydraulic presses covered by the scope of this standard. The technical measures and information for use contained in clauses 5 and 7 and the annexes are based on the risk assessment, and deal with the identified hazards by either eliminating them or reducing the effects of the risks they generate.

4.2 The risk assessment assumes foreseeable access from all directions, as well as unexpected and unintended strokes or gravity falls. Risks to both the operators and other persons who may have access to the danger zones are identified, taking into account all hazards which may occur during the life of the press. The assessment includes an analysis of the effect of failure in the control system.

4.3 In addition, the user of this standard, i.e. the designer, manufacturer or supplier, shall conduct a risk assessment in accordance with EN 1050 with particular attention to:

- the intended use of the press including maintenance, toolsetting and cleaning, and its reasonably foreseeable misuse;
- the identification of the significant hazards associated with the press (see 4.4).

4.4 Table 1 of this standard is a list of significant hazards and their related danger zones normally associated with a hydraulic press. As part of the risk assessment, the designer shall verify whether the list of hazards in table 1 is exhaustive and applicable to the press under consideration.

(standards.iteh.ai)

SIST EN 693:2001+A1:2009

<https://standards.iteh.ai/catalog/standards/sist/aef1baa1-08b1-4c2d-8d20-acc08b0bd931/sist-en-693-2001a1-2009>

Table 1 — Significant hazards, danger zones, preventive measures

Hazards	Danger zone	Preventive measures: relevant clauses of this standard	Relevant clauses of EN 292-1
Mechanical hazards Crushing hazard Shearing hazard Cutting or severing hazard Entanglement hazard Drawing-in or trapping hazard Impact hazard	Tools area: - between moving tools - moving slide - moving die cushions - workpiece ejectors - guards Moving parts of electrical, hydraulic and pneumatic equipment Motor and drive machinery Mechanical handling device	5.2 to 5.5 Annexes C, D and E 5.6.1 to 5.6.3 5.6.1 to 5.6.4	4.2.1
Ejection hazard	Machine components Workpieces and tools	5.6.5 7.2.2 i)	
High pressure fluid ejection hazard	Hydraulic systems	5.8.3	4.2.1
Slip, trip and fall hazards	All work at heights Floor area around the press	5.7	4.2.3
Electrical hazards Direct contact hazard	Electrical equipment	5.8.1	4.3
Indirect contact hazard	Electrical equipment Parts made live by electrical equipment under fault conditions	5.8.1	4.3
Thermal radiation hazard (burns)			
Thermal hazards resulting in burns and scalds, by a possible contact of persons	Parts of the hydraulic system	5.8.2	4.4
Hazards generated by noise resulting in hearing losses (deafness)	Any area at the press where there is a risk to hearing	5.8.4	4.5
Hazards generated by vibration	Parts of the press where the risk occurs, e.g. the workstation(s)	5.8.5	4.6
Hazards generated by materials and substances processed, used or exhausted by machinery , for example: Hazards resulting from contact with or inhalation of harmful fluids, gases, mists, fumes and dusts	Hydraulic systems; pneumatic systems and their controls; toxic work materials	5.8.6.1 to 5.8.6.3	4.8
Fire or explosion hazards	Exhaust ventilation and dust collection equipment	5.8.6.4	4.8
Hazards generated by neglecting ergonomic principles in machine design (mismatch of machinery with human characteristics and abilities) caused, for example, by unhealthy postures or excessive efforts	The working position and controls for operators and maintenance staff handling tools	5.8.7	4.9