



SLOVENSKI STANDARD
SIST EN 709:1998+A2:2009

01-julij-2009

Šta Yh'g_]b[cnXUfg_]glfc'!'9bccgb]'fU_hcf'g'df[_`f Yb]a `dfY_cdUb]_ca ž
a clcfb]'dfY_cdUb]_]b'a clcfb]'dfY_cdUb]_]g'dc[cbg_]a fU'c`Ygca fU'!JUfbcgh

Agricultural and forestry machinery - Pedestrian controlled tractors with mounted rotary cultivators, motor hoes, motor hoes with drive wheel(s) - Safety

Maschinen für die Land- und Forstwirtschaft - Einachstraktoren mit angebaute Fräse, Motorhacken, Triebhacken - Sicherheit

Matériel agricole et forestier - Motoculteurs avec fraises portées, motobineuses et fraises à roue(s) motrice(s) - Sécurité

<https://standards.iteh.ai/catalog/standards/sist/34f59fd1-fe44-4ec0-a39a-728dd99e9c79/sist-en-709-1998a2-2009>

Ta slovenski standard je istoveten z: **EN 709:1997+A2:2009**

ICS:

- | | | |
|-----------|----------------------------------|--|
| 65.060.10 | Kmetijski traktorji in prikolice | Agricultural tractors and trailed vehicles |
| 65.060.20 | Oprema za obdelovanje tal | Soil-working equipment |

SIST EN 709:1998+A2:2009

en

iTeh STANDARD PREVIEW
(standards.iteh.ai)

SIST EN 709:1998+A2:2009

<https://standards.iteh.ai/catalog/standards/sist/34f59fd1-fe44-4ec0-a39a-728dd99e9c79/sist-en-709-1998a2-2009>

EUROPEAN STANDARD

EN 709:1997+A2

NORME EUROPÉENNE

EUROPÄISCHE NORM

May 2009

ICS 65.060.10; 65.060.20

Supersedes EN 709:1997

English Version

Agricultural and forestry machinery - Pedestrian controlled tractors with mounted rotary cultivators, motor hoes, motor hoes with drive wheel(s) - Safety

Matériel agricole et forestier - Motoculteurs avec fraises portées, motobineuses et fraises à roue(s) motrice(s) - Sécurité

Maschinen für die Land- und Forstwirtschaft - Einachstraktoren mit angebauter Fräse, Motorhacken, Triebhacken - Sicherheit

This European Standard was approved by CEN on 4 March 1997 and includes Amendment 1 approved by CEN on 1 July 1999 and Amendment 2 approved by CEN on 29 December 2008.

CEN members are bound to comply with the CEN/CENELEC Internal Regulations which stipulate the conditions for giving this European Standard the status of a national standard without any alteration. Up-to-date lists and bibliographical references concerning such national standards may be obtained on application to the CEN Management Centre or to any CEN member.

This European Standard exists in three official versions (English, French, German). A version in any other language made by translation under the responsibility of a CEN member into its own language and notified to the CEN Management Centre has the same status as the official versions.

CEN members are the national standards bodies of Austria, Belgium, Bulgaria, Cyprus, Czech Republic, Denmark, Estonia, Finland, France, Germany, Greece, Hungary, Iceland, Ireland, Italy, Latvia, Lithuania, Luxembourg, Malta, Netherlands, Norway, Poland, Portugal, Romania, Slovakia, Slovenia, Spain, Sweden, Switzerland and United Kingdom.



EUROPEAN COMMITTEE FOR STANDARDIZATION
COMITÉ EUROPÉEN DE NORMALISATION
EUROPÄISCHES KOMITEE FÜR NORMUNG

Management Centre: Avenue Marnix 17, B-1000 Brussels

Contents

Page

Foreword.....	4
Introduction	5
1 Scope	5
2 Normative references	5
3 Definitions	6
4 List of hazards.....	6
5 Safety requirements and/or measures	7
5.1 General.....	7
5.2 Starting device	7
5.3 Manual controls	8
5.4 Identification of controls	9
5.5 Controls of the movement of the machine and of the tool.....	10
5.6 Reverse gear	10
5.7 Guards for moving parts.....	10
5.7.1 General.....	10
5.7.2 Soil working tool.....	10
5.8 Handlebars	14
5.8.1 General.....	14
5.8.2 Motor hoes.....	14
5.9 Exhaust system.....	15
5.9.1 Protection against exhaust gas.....	15
5.9.2 Protection against hot surfaces.....	16
5.10 Steering mechanisms.....	17
5.10.1 General.....	17
5.10.2 Measurement of the steering force	17
5.11 Brakes	18
5.12 Electrical installation	18
5.13 Noise	19
5.13.1 General.....	19
5.13.2 Operating conditions.....	19
5.14 Vibration	19
5.14.1 A1) Reduction by design and protective measures	19
5.14.2 Reduction by information	19
5.14.3 Vibration measurement A1).....	20
6 Information for use	20
6.1 Instruction handbook	20
6.2 Marking	22
Annex A (normative) List of hazards.....	24
Annex B (informative) Examples of machines	30
Annex C (normative) A1) Measurement of vibration at the handlebars A1)	32
C.1 General.....	32
C.2 Quantities to be measured.....	32
C.3 Instrumentation.....	32
C.3.1 General.....	32
C.4 Fastening of the transducer	32
C.5 Calibration	33
C.6 Measurement location and direction	33

C.7	Pre - test	33
C.8	Test conditions	33
C.8.1	Machine set-up	33
C.8.2	Operating conditions	33
C.8.3	Operator.....	34
C.9	Measurement procedure.....	34
C.10	Test report.....	34
Annex ZA (informative)  Relationship between this European Standard and the Essential Requirements of EU Directive 98/37/EC, amended by Directive 98/79/EC 		37
Annex ZB (informative)  Relationship between this European Standard and the Essential Requirements of EU Directive 2006/42/EC 		38
Bibliography.....		39

iTeh STANDARD PREVIEW (standards.iteh.ai)

[SIST EN 709:1998+A2:2009](https://standards.iteh.ai/catalog/standards/sist/34f59fd1-fe44-4ec0-a39a-728dd99e9c79/sist-en-709-1998a2-2009)

<https://standards.iteh.ai/catalog/standards/sist/34f59fd1-fe44-4ec0-a39a-728dd99e9c79/sist-en-709-1998a2-2009>

EN 709:1997+A2:2009 (E)**Foreword**

This document (EN 709:1997+A2:2009) has been prepared by Technical Committee CEN/TC 144 "Tractors and machinery for agriculture and forestry", the secretariat of which is held by AFNOR.

This European Standard shall be given the status of a national standard, either by publication of an identical text or by endorsement, at the latest by September 2009, and conflicting national standards shall be withdrawn at the latest by December 2009.

This document includes Amendment 1, approved by CEN on 1999-07-01 and Amendment 2, approved by CEN on 2008-12-29.

This document supersedes EN 709:1997.

The start and finish of text introduced or altered by amendment is indicated in the text by tags **A₁**, **A₁** and **A₂**, **A₂**.

This European Standard has been prepared under a mandate given to CEN by the European Commission and the European Free Trade Association, and supports essential requirements of EU Directive(s).

A₂ For relationship with EU directive(s), see informative Annexes ZA and ZB, which are integral parts of this document. **A₂**

The Annex A is normative and contains the "List of hazards".

According to the CEN/CENELEC Internal Regulations, the national standards organizations of the following countries are bound to implement this European Standard: Austria, Belgium, Bulgaria, Cyprus, Czech Republic, Denmark, Estonia, Finland, France, Germany, Greece, Hungary, Iceland, Ireland, Italy, Latvia, Lithuania, Luxembourg, Malta, Netherlands, Norway, Poland, Portugal, Romania, Slovakia, Slovenia, Spain, Sweden, Switzerland and United Kingdom.

Introduction

The extent to which hazards are covered is indicated in the scope of this standard.

In addition, machines shall comply – as appropriate – with EN 292 for hazards which are not dealt with and especially with Annex A of EN 292-2:1991/A1:1995 when EN 292 does not give precise requirements.

1 Scope

This European Standard specifies safety requirements and testing for design and construction of, pedestrian controlled tractors with mounted rotary cultivators with the cultivator rotating axis horizontal and perpendicular to the direction of motion of the machine, motor hoes and motor hoes with drive wheel(s), all as used in agriculture, forestry, landscaping and gardening (including amenity use).

It describes methods for the elimination or reduction of risks arising from their use. In addition, it specifies the type of information to be provided by the manufacturer on safe working practices.

This European Standard does not cover the requirements to fulfil national road traffic regulations such as lights, steering and braking.

Environmental aspects have not been considered in this standard.

This European Standard applies primarily to machines which are manufactured after the date of issue of the standard.

[SIST EN 709:1998+A2:2009
https://standards.iteh.ai/catalog/standards/sist/34f59fd1-fe44-4ec0-a39a-728dd99e9c79/sist-en-709-1998a2-2009](https://standards.iteh.ai/catalog/standards/sist/34f59fd1-fe44-4ec0-a39a-728dd99e9c79/sist-en-709-1998a2-2009)

2 Normative references

This European Standard incorporates by dated or undated reference, provisions from other publications. These normative references are cited at the appropriate places in the text and the publications are listed hereafter. For dated references, subsequent amendments to or revisions of any of these publications apply to this European Standard only when incorporated in it by amendment or revision. For undated references, the latest edition of the publication referred to applies.

EN 292-1:1991, *Safety of machinery - Basic concepts, general principles for design - Part 1: Basic terminology, methodology.*

EN 292-2:1991, *Safety of machinery - Basic concepts, general principles for design - Part 2: Technical principles and specifications.*

EN 292-2:1991/A1:1995, *Safety of machinery - Basic concepts, general principles for design - Part 2: Technical principles and specifications.*

EN 294:1992, *Safety of machinery - Safety distances to prevent danger zones being reached by the upper limbs.*

EN 563:1994, *Safety of machinery – Temperatures of touchable surfaces – Ergonomics data to establish temperature limit value for hot surfaces.*

EN 1033:1995, *Hand-arm vibration – Laboratory measurement of vibration at the grip surface of hand-guided machinery – General.*

EN 709:1997+A2:2009 (E)

prEN 1553:1996, *Agricultural, forestry, landscaping and garden machinery – Common requirements – Safety.*

Ⓐ) CR 1030-1:1995, *Hand-arm vibration – Guidelines for vibration hazards reduction – Part 1: Engineering methods by design of machinery*

ISO 5805:1981, *Mechanical vibration and shock affecting man - Vocabulary* Ⓐ)

EN ISO 3767-1:1995, *Tractors, machinery for agriculture and forestry, powered lawn and garden equipment – Symbols for operator controls and other displays – Part 1: Common symbols.*

EN ISO 3767-3:1996, *Tractors, machinery for agriculture and forestry, powered lawn and garden equipment – Symbols for operator controls and other displays – Part 3: Symbols for powered lawn and garden equipment.*

3 Definitions

For the purposes of this standard, the definitions given in EN 292-1:1991 apply together with the following:

3.1 pedestrian controlled tractor
agricultural self-propelled machine designed to be pedestrian controlled, capable of driving and/or pulling different working tools (see Figure B.1)

3.2 tool
working element which can be adapted to a pedestrian controlled tractor

3.3 mounted rotary cultivator
tool used for working the soil composed of a group of rotating elements which can be adapted to a pedestrian controlled tractor.

3.4 motor hoe
agricultural self-propelled machine designed to be pedestrian controlled with or without support wheel(s), in such a way that its working elements act as hoeing tools to ensure propulsion (see figure B.2)

3.5 motor hoe with drive wheel(s)
agricultural self-propelled machine designed to be pedestrian controlled and propelled by one or various wheels directly actuated from the engine and equipped with hoeing tools (see figure B.3).

3.6 handlebar
device equipped with grips enabling the machine to be manually controlled.

4 List of hazards

The list of significant hazards dealt with in this standard is given in Annex A.

Annex A also indicates the hazards which have not been dealt with.

5 Safety requirements and/or measures

5.1 General

Unless otherwise specified in this standard, the machine shall comply with the requirements of tables 1, 3, 4 and 6 of EN 294:1992.

The requirements of prEN 1553 apply where relevant.

5.2 Starting device

In addition to the hold-to-run controls (see 5.5) the machines shall be equipped with a device which prevents the engine starting if the start-up can induce rotation of the wheels or movement of the tool.

The type of device which can be considered as fulfilling this requirement is one which, for example, by a mechanical linkage only allows the engine to start when the gear lever is in neutral and the tool is declutched.

Such a device is not necessary if, when starting the machine according to the instructions, the operator is not required to be in the danger zone. The danger zone is taken as the longitudinal band defined by the width of the machine and tool extending both forward and rearwards from it. If the machine is not provided with reverse gear, the danger zone to the rear of the machine is limited to a distance of 550 mm as measured from the rear extremity of the protective devices for moving parts (see figure 1).

In the case of a machine provided with reverse gear, the danger zone to the rear includes the whole longitudinal zone limited by the working width of the equipment.

Should the operator have to lean on the machine to start the engine, the appropriate place shall be indicated or an identified support provided with a corresponding indication.

With the exception of hand cranks (see ISO/DIS 11102-1 and ISO/DIS 11102-2), starting devices shall be integral with the machine (e.g. recoil pull start). Loose belts, cables, etc. are not accepted.

If starting is achieved by means of a hand crank, it shall be equipped with a device that disconnects the hand crank immediately when the engine starts and prevents its connection when the engine is running or kick-back during starting.

Dimensions in millimetres

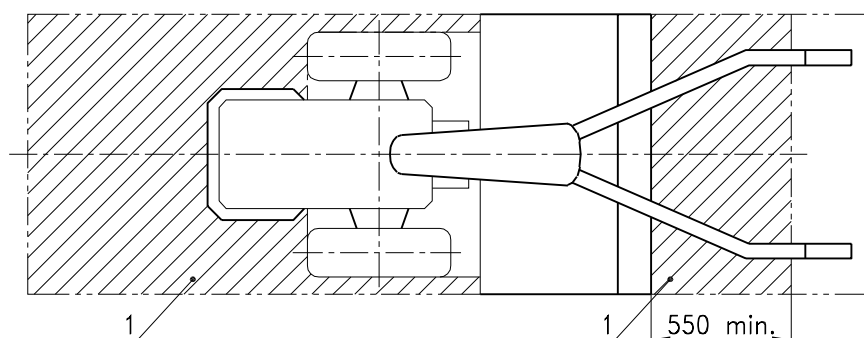

Figure 1 — Limits of the danger zone when operating the starting device for machines with no reverse gear

EN 709:1997+A2:2009 (E)**5.3 Manual controls**

The height of the handlebar grips in relation to the ground shall be adjustable.

The following manually operated controls shall be within the "hand reach zone" from the normal operator working position:

- clutch;
- brakes;
- gearbox (within the selected range);
- reversing device;
- steering system;
- engine working speed;
- hold-to-run control (see 5.5);
- tool clutch lever;
- stop control.

The "hand reach zone" (see figure 2) is defined as the truncated hemispherical volume of radius $R = 800$ mm with its centre at the midpoint (point B in figure 2) of a line joining the handlebar grip ends when the grips are set to a height of 800 mm above the ground, or set to the next available lowest height setting where this is not available, with its flat face on the vertical plane tangential to the handlebar grip ends and facing rearwards, and truncated below by a plane parallel to the ground positioned 450 mm above the ground.

The engine stopping device shall not depend on sustained manual pressure for its operation.

iTeh STANDARD PREVIEW
(standards.iteh.ai)

[SIST EN 709:1998+A2:2009](https://standards.iteh.ai/catalog/standards/sist/34f59fd1-fe44-4ec0-a39a-728dd99e9c79/sist-en-709-1998a2-2009)

<https://standards.iteh.ai/catalog/standards/sist/34f59fd1-fe44-4ec0-a39a-728dd99e9c79/sist-en-709-1998a2-2009>

Dimensions in millimetres

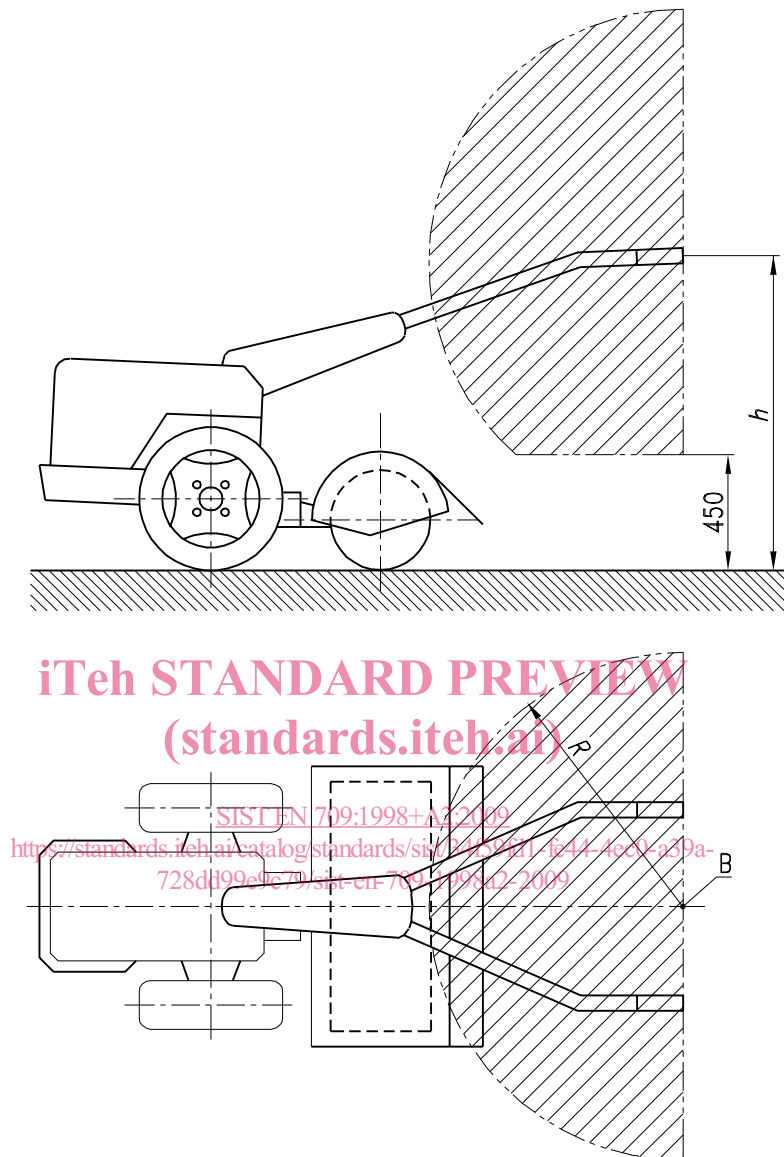

Figure 2 — "Hand reach zone" volume

5.4 Identification of controls

The controls used for driving the working tool and for locking the differential in their different positions shall be marked.

The gear positions (including the neutral position) shall be durably and clearly marked and located within the field of vision of the operator.

Detailed instructions on the operation of all controls shall be provided in the instruction handbook.

Symbols in accordance with EN ISO 3767-1:1995 and EN ISO 3767-3:1996 shall be used as appropriate.

EN 709:1997+A2:2009 (E)**5.5 Controls of the movement of the machine and of the tool**

All movements of the machine and of the working tool shall be stopped when the hold-to-run control(s) is (are) released.

The hold-to-run control(s) shall not extend beyond the end of the handlebar grips.

The movement of the machine or of the tools shall not start unless the operator is able to grip both the control(s) and the handlebar grip.

5.6 Reverse gear

In all machines with reverse gear, it shall not be possible to go directly from forward to reverse motion. This requirement is fulfilled, for example, by providing a neutral position.

In the case of pedestrian controlled tractors and motor hoes with drive wheel, it shall not be possible to operate the working tool and the reverse gear simultaneously (e.g. by having a mechanical interlock on the reverse gear).

For motor hoes without drive wheel, the maximum design reverse speed at rated engine speed shall not exceed 1 m/s.

5.7 Guards for moving parts**5.7.1 General**

5.7.1.1 Moving transmission parts which generate hazards shall be protected by means of fixed guards.

5.7.1.2 If, according to the instruction handbook, frequent access is foreseen e.g. for adjustment or maintenance, guards shall be used which remain attached to the machine (e.g. by means of hinges), and which can only be opened by using a tool and which automatically lock without the use of a tool.

5.7.1.3 If this type of guard is not used, movable guards as specified in 4.2.2.3 of EN 292-2:1991 shall be provided, which:

- Cause the dangerous movement to stop before reaching the danger zone; or
- Do not open until the dangerous movement ceases.

5.7.2 Soil working tool

The operator driving the machine shall be protected by the design of the machine from unintentional contact with the soil working tool.

The protective device shall be designed with a minimum thickness of 2 mm of steel or equivalent material, and fulfil the requirements in 5.7.2.1 and 5.7.2.2.

NOTE Subsequent revision of this standard will provide adequate test methods.

5.7.2.1 Pedestrian controlled tractors and motor hoes with drive wheel

The tools shall have a full cover from over the full working width with no openings. The cover shall extend forward by an angle of at least 60° to the vertical plane which cuts through the rotating axis of the working tool (see figure 3).

The upper covering shall also extend rearwards and downwards (depending on the length of the handlebars) so that the minimum values indicated in table 1 for m and n are reached (see figure 3). Hinged covering is allowed providing that it always remains in contact with the soil without any external action during work.

Table 1 — Clearance from the handlebar grips to the working tool and minimum dimensions of the guard devices (figure 3)

Dimensions in millimetres

l	m	n	Position of point D
$l \geq 700$	150	20	3 (G)
$600 \leq l < 700$	180	$1/3 r$	2
$500 \leq l < 600$ ¹⁾	230	$2/3 r$	1
¹⁾ Applicable only to machines having an engine power up to 4 kW or to machines having a mass less than 120 kg			

iTeh STANDARD PREVIEW (standards.iteh.ai)

[SIST EN 709:1998+A2:2009
https://standards.iteh.ai/catalog/standards/sist/34f59fd1-fe44-4ec0-a39a-728dd99e9c79/sist-en-709-1998a2-2009](https://standards.iteh.ai/catalog/standards/sist/34f59fd1-fe44-4ec0-a39a-728dd99e9c79/sist-en-709-1998a2-2009)