



**SLOVENSKI STANDARD**  
**SIST EN 12733:2001+A1:2009**

**01-maj-2009**

**BUXca Yý U**  
**SIST EN 12733:2001**

---

Štandard za varnost pri uporabi ročnih motornih kosilnic - Varnost

Agricultural and forestry machinery - Pedestrian controlled motor mowers - Safety

Land- und forstwirtschaftliche Maschinen - Handgeführte Motormäher - Sicherheit

**iTeh STANDARD PREVIEW**  
Matériel agricole et forestier - Motofaucheuses à conducteur à pied - Sécurité  
**(standards.iteh.ai)**

**Ta slovenski standard je istoveten z: EN 12733:2001+A1:2009**

<https://standards.iteh.ai/catalog/standards/sist/476bd10f-2649-48f2-bc24-5fb4a6ee75e8/sist-en-12733-2001a1-2009>

**ICS:**

65.060.50 Oprema za spravilo pridelkov Harvesting equipment

**SIST EN 12733:2001+A1:2009**

**en,fr**

**iTeh STANDARD PREVIEW**  
**(standards.iteh.ai)**

[SIST EN 12733:2001+A1:2009](#)

<https://standards.iteh.ai/catalog/standards/sist/476bd10f-2649-48f2-bc24-5fb4a6ee75c8/sist-en-12733-2001a1-2009>

EUROPEAN STANDARD

**EN 12733:2001+A1**

NORME EUROPÉENNE

EUROPÄISCHE NORM

March 2009

ICS 65.060.50

Supersedes EN 12733:2001

English Version

**Agricultural and forestry machinery - Pedestrian controlled motor mowers - Safety**

Matériel agricole et forestier - Motofaucheuses à conducteur à pied - Sécurité

Land- und forstwirtschaftliche Maschinen - Handgeführte Motormäher - Sicherheit

This European Standard was approved by CEN on 21 January 2001 and includes Corrigendum 1 issued by CEN on 15 October 2003 and Amendment 1 approved by CEN on 29 December 2008.

CEN members are bound to comply with the CEN/CENELEC Internal Regulations which stipulate the conditions for giving this European Standard the status of a national standard without any alteration. Up-to-date lists and bibliographical references concerning such national standards may be obtained on application to the CEN Management Centre or to any CEN member.

This European Standard exists in three official versions (English, French, German). A version in any other language made by translation under the responsibility of a CEN member into its own language and notified to the CEN Management Centre has the same status as the official versions.

CEN members are the national standards bodies of Austria, Belgium, Bulgaria, Cyprus, Czech Republic, Denmark, Estonia, Finland, France, Germany, Greece, Hungary, Iceland, Ireland, Italy, Latvia, Lithuania, Luxembourg, Malta, Netherlands, Norway, Poland, Portugal, Romania, Slovakia, Slovenia, Spain, Sweden, Switzerland and United Kingdom.

[SIST EN 12733:2001+A1:2009](https://standards.iteh.ai/catalog/standards/sist/476bd10f-2649-48f2-bc24-5fb4a6ce75c8/sist-en-12733-2001a1-2009)

<https://standards.iteh.ai/catalog/standards/sist/476bd10f-2649-48f2-bc24-5fb4a6ce75c8/sist-en-12733-2001a1-2009>



EUROPEAN COMMITTEE FOR STANDARDIZATION  
COMITÉ EUROPÉEN DE NORMALISATION  
EUROPÄISCHES KOMITEE FÜR NORMUNG

Management Centre: Avenue Marnix 17, B-1000 Brussels

## Contents

Foreword.....	4
Introduction .....	5
1 Scope .....	5
2 Normative references .....	5
3 Terms and definitions .....	7
4 List of hazards.....	8
5 Safety requirements and/or measures .....	8
5.1 General.....	8
5.2 Engine starting and stopping devices.....	8
5.3 Manual controls .....	9
5.4 Marking of controls.....	10
5.5 Controls of the movement of the machine and of the blade(s) .....	10
5.6 Reverse gear .....	11
5.7 Handlebars .....	11
5.8 Pressurized components .....	11
5.9 Liquid spillage.....	11
5.10 Exhaust system.....	11
5.11 Steering mechanism.....	14
5.12 Brakes .....	16
5.13 Electrical installations.....	17
5.14 Noise .....	17
5.15 Vibration .....	17
6 Specific requirements .....	18
6.1 Sickle bar mowers .....	18
6.2 Grassland mowers.....	19
6.3 Flail mowers .....	30
6.4 Scrub clearing machines .....	32
7 Information for use .....	35
7.1 Instruction handbook .....	35
7.2 Marking .....	36
Annex A (normative) List of hazards.....	37
Annex B (normative) Noise test code for motor mowers - Engineering method (grade 2) .....	42
B.0 Scope .....	42
B.1 A-weighted sound power level determination .....	42
B.2 A-weighted emission sound pressure level determination.....	44
B.3 Requirements for test floor.....	44
B.4 Installation, mounting and operating conditions .....	44
B.5 Measurement uncertainties and declaration of noise emission values.....	45
B.6 Information to be recorded and reported .....	45
Annex C (normative) Vibration measurement of motor mowers .....	46
C.1 Quantities to be measured.....	46
C.2 Instrumentation.....	46
C.3 Measurement direction and measurement location.....	46
C.4 Test procedure .....	47
C.5 Measurement procedure .....	48
C.6 Determination of the measurement result .....	49
Annex D (normative) Foot probe test.....	50
D.1 Test equipment .....	50
D.2 Test method.....	50
D.3 Test acceptance .....	50
Annex E (normative) Material of protective skirts .....	52

E.1	Tearing resistance test.....	52
E.2	Perforation resistance test .....	52
E.3	Wear resistance test.....	52
<b>Annex F</b>	<b>(normative) Corrugated fibreboard penetration tests on grassland mowers - Test enclosure wall panels (see 6.2.2.2.4.2) .....</b>	<b>53</b>
F.1	Purpose.....	53
F.2	Test fixture .....	53
F.3	Fibreboard samples.....	53
F.4	Procedure .....	53
F.5	Acceptance criteria.....	53
<b>Annex G</b>	<b>(normative) Target elevation areas.....</b>	<b>55</b>
G.1	Lower elevation target.....	55
G.2	Middle elevation target.....	55
G.3	Top elevation target.....	55
G.4	Operator target area .....	55
<b>Annex H</b>	<b>(normative) Test enclosure .....</b>	<b>56</b>
H.1	Base .....	56
H.2	Target composition .....	56
<b>Annex I</b>	<b>(normative) Thrown object test for flail mower.....</b>	<b>59</b>
I.1	Principle.....	59
I.2	Test installation .....	59
I.3	Test procedure.....	62
I.4	Test result.....	63
I.5	Acceptance criteria.....	63
<b>Annex J</b>	<b>(normative) Thrown object test for scrub clearing machines.....</b>	<b>64</b>
J.1	Test equipment .....	64
J.2	Test method .....	64
J.3	Data sheet - Thrown object test for scrub clearing machine .....	66
<b>Annex K</b>	<b>(informative) Example of a material and construction fulfilling the requirements for an artificial surface .....</b>	<b>68</b>
K.1	Material .....	68
K.2	Construction .....	68
<b>Annex L</b>	<b>(informative) Examples of machines.....</b>	<b>71</b>
<b>Annex ZA</b>	<b>(informative) <math>\text{A}_1</math> Relationship between this European Standard and the Essential Requirements of EU Directive 98/37/EC, amended by Directive 98/79/EC <math>\text{A}_1</math> .....</b>	<b>72</b>
<b>Annex ZB</b>	<b>(informative) <math>\text{A}_1</math> Relationship between this European Standard and the Essential Requirements of EU Directive 2006/42/EC <math>\text{A}_1</math>.....</b>	<b>73</b>
<b>Bibliography</b>	<b>.....</b>	<b>74</b>

**EN 12733:2001+A1:2009 (E)****Foreword**

This document (EN 12733:2001+A1:2009) has been prepared by Technical Committee CEN/TC 144 "Tractors and machinery for agriculture and forestry", the secretariat of which is held by AFNOR.

This European Standard shall be given the status of a national standard, either by publication of an identical text or by endorsement, at the latest by September 2009, and conflicting national standards shall be withdrawn at the latest by December 2009.

This European Standard was approved by CEN on 21 January 2001 and includes Corrigendum 1 issued by CEN on 15 October 2003 and Amendment 1 approved by CEN on 29 December 2008.

This document supersedes EN 12733:2001.

The start and finish of text introduced or altered by amendment is indicated in the text by tags  $\boxed{A_1}$   $\langle A_1 \rangle$ .

The modifications of the related CEN Corrigendum have been implemented at the appropriate places in the text and are indicated by the tags  $\boxed{AC}$   $\langle AC \rangle$ .

This European Standard has been prepared under a mandate given to CEN by the European Commission and the European Free Trade Association, and supports essential requirements of EU Directive(s).

$\boxed{A_1}$  For relationship with EU Directive(s), see informative Annexes ZA and ZB, which are integral parts of this document.  $\langle A_1 \rangle$

**STANDARD PREVIEW**  
(standards.iteh.ai)

Annexes A, B, C, D, E, F, G, H, I and J are normative. Annexes K and L are informative.

According to the CEN/CENELEC Internal Regulations, the national standards organizations of the following countries are bound to implement this European Standard: Austria, Belgium, Bulgaria, Cyprus, Czech Republic, Denmark, Estonia, Finland, France, Germany, Greece, Hungary, Iceland, Ireland, Italy, Latvia, Lithuania, Luxembourg, Malta, Netherlands, Norway, Poland, Portugal, Romania, Slovakia, Slovenia, Spain, Sweden, Switzerland and United Kingdom.

## Introduction

The extent to which hazards are covered is indicated in the scope of this standard.

### 1 Scope

This standard specifies safety requirements and their verification for design and construction of pedestrian controlled motor mowers with rotary or reciprocating cutting blades used in agricultural, forestry and landscaping to cut and/or mulch grass or similar plants or scrub and woody vegetation. For the purposes of this standard the following types of pedestrian controlled machines are considered to be motor mowers:

- flail mowers;
- grassland mowers;
- scrub clearing machines;
- sickle bar mowers.

This standard applies also to multipurpose machines when are used for cutting or mulching grass or scrub.

This standard does not cover lawn mowers (see EN 836), engine driven brush cutters and grass trimmers (see EN ISO 11806) or other lawn maintenance equipment.

This standard describes methods for the elimination or reduction of hazards arising from the use of motor mowers. Additionally, it specifies the type of information to be provided by the manufacturer on safe working practices.

Environmental aspects have not been considered in this standard.

This standard applies primarily to machines which are manufactured after the date of issue of the standard.

### 2 Normative references

This European Standard incorporates by dated or undated reference, provisions from other publications. These normative references are cited at the appropriate places in the text and the publications are listed hereafter. For dated references, subsequent amendments to or revisions of any of these publications apply to this European Standard only when incorporated in it by amendment or revision. For undated references the latest edition of the publication referred to applies (including amendments).

EN 292-1:1991, *Safety of machinery — Basic concepts, general principles for design — Part 1: Basic terminology, methodology.*

EN 292-2:1991+A1:1995, *Safety of machinery — Basic concepts, general principles for design — Part 2: Technical principles and specifications.*

EN 294:1992, *Safety of machinery — Safety distances to prevent danger zones being reached by the upper limbs.*

EN 709:1997, *Agricultural and forestry machinery — Pedestrian controlled tractors with mounted rotary cultivators, motor hoes, motor hoes with drive wheel(s) — Safety.*

EN 836:1997, *Garden equipment — Powered lawnmowers — Safety.*

**EN 12733:2001+A1:2009 (E)**

CR 1030-1:1995:1995, *Hand-arm vibration — Guidelines for vibration hazards reduction — Part 1: Engineering methods by design of machinery.*

EN 1033:1995, *Hand-arm vibration — Laboratory measurement of vibration at the grip surface of hand-guided machinery – General.*

EN ISO 354:1993, *Acoustics — Measurement of sound absorption in a reverberation room (ISO 354:1985).*

EN 60651:1994, *Sound level meters (IEC 60651:1993).*

EN 60804:1994, *Integrating-averaging sound level meters (IEC 60804:1985 and A1:1989).*

EN ISO 3744:1995, *Acoustics — Determination of sound power levels of noise sources using sound pressure — Engineering method in an essentially free field over a reflecting plane (ISO 3744:1994).*

ISO 3767-1:1991, *Tractors, machinery for agriculture and forestry, powered lawn and garden equipment — Symbols for operator controls and other displays — Part 1: Common symbols.*

ISO 3767-3:1995, *Tractors, machinery for agriculture and forestry, powered lawn and garden equipment — Symbols for operator controls and other displays — Part 3: Symbols for powered lawn and garden equipment.*

EN ISO 4871:1996, *Acoustics — Declaration and verification of noise emission values of machinery and equipment (ISO 4871:1996).*

EN ISO 11201:1995, *Acoustics — Noise emitted by machinery and equipment — Measurement of emission sound pressure levels at a work station and at other specified positions — Engineering method in an essentially free field over a reflecting plane (ISO 11201:1995).*

EN ISO 11688-1:1998, *Acoustics — Recommended practice for the design of low-noise machinery and equipment — Part 1: Planning (ISO/TR 11688-1:1995).*

EN ISO 11688-2:2000, *Acoustics — Recommended practice for the design of low-noise machinery and equipment — Part 2: Introduction to the physics of low-noise design.*

<https://standards.iteh.ai/catalog/standards/sist/476bd10f-2649-48f2-bc24-91046c978384/en-12733-2001a1-2009>

ISO 2758:1983, *Paper — Determination of bursting strength*

ISO 3789-1:1982, *Tractors, machinery for agriculture and forestry, powered lawn and garden equipment — Location and method of operation of operator controls — Part 1: Common controls.*

ISO 5718-1:1989, *Harvesting equipment — Flat blades for rotary mowers — Specifications — Part 1: Type A flat blades.*

ISO 5718-2:1991, *Harvesting equipment — Flat blades for rotary mowers — Part 2: Specifications for type B flat blades.*

ISO 11102-1:1997, *Reciprocating internal combustion engines — Handle starting equipment — Part 1: Safety requirements and tests.*

ISO 11102-2:1997, *Reciprocating internal combustion engines — Handle starting equipment — Part 2: Method of testing the angle of disengagement.*



### 3 Terms and definitions

For the purposes of this standard, the terms and definitions given in EN 292-1:1991 and EN 292-2:1991/A1:1995 apply together with the following:

#### 3.1

##### **sickle bar mower**

motor mower which uses a power source to reciprocate a knife or knives to provide a shearing action with a stationary cutter bar or movable knife (see Figure L.1)

NOTE Adapted from EN 836:1997.

#### 3.2

##### **rotary cutting blade**

cutting blade on which one or more knives or several blades fixed on drums or discs rotate around a vertical or horizontal axis

#### 3.3

##### **grassland mower**

motor mower with rotary cutting blade(s) rotating about a vertical axis designed for cutting or mulching high grass, the cutting blade protective enclosure of which is not fully enclosing (see Figure L.2). The minimum cutting height is limited by design to 50 mm

#### 3.4

##### **flail mower**

grass-cutting machine with a multiplicity of free-swinging cutting elements that rotate about an axis parallel to the cutting plane and cut by impact

[EN 836:1997]

#### 3.5

**scrub clearing machine** motor mower with rotary cutting blade(s) rotating about a vertical axis designed for cutting scrub and woody vegetation. There is no ground support in front of cutting blade(s). The front of the machine is supported at either side by skids, not wheels. At the front the cutting blade(s) enclosure may be open (see Figure L.3)

#### 3.6

##### **discharge opening**

opening in the protective enclosure of the cutting blade through which the cut material can be ejected

#### 3.7

##### **discharge chute**

extension of the discharge opening generally used to safely guide the ejection of the material coming from the cutting blade

#### 3.8

##### **handlebar**

device equipped with grips enabling the machine to be manually controlled

[EN 709:1997]

#### 3.9

##### **maximum operating engine speed**

highest engine speed obtainable when adjusted in accordance with the machine manufacturer's specifications and/or instructions with the cutting blades engaged

NOTE Adapted from EN 836:1997.

**EN 12733:2001+A1:2009 (E)****3.10****normal operation**

any use of the machine which is reasonably foreseeable, as seen by the user, and which is consistent with such activities as cutting grass, starting, stopping, fuelling, or connecting to (or disconnecting from) a power source

NOTE Adapted from EN 836:1997.

**3.11****normal use**

normal operation, plus routine maintenance, servicing, cleaning, transporting, attaching or removing accessories, and making ordinary adjustments as determined by the manufacturer's instructions

[EN 836:1997]

**3.12****multipurpose machine**

machine on which different attachments can be mounted

**4 List of hazards**

The hazards, among those appearing in EN 292-1:1991, EN 292-2:1991 and EN 292-2:1991/A1:1995 considered as applicable to the machines covered in this standard, are given in annex A.

**5 Safety requirements and/or measures**

**iTeh STANDARD PREVIEW**  
(standards.iteh.ai)

**5.1 General**

Unless otherwise specified in this standard, the machine shall conform to the requirements of Tables 1, 3, 4 and 6 of EN 294:1992.

[SIST EN 12733:2001+A1:2009](https://standards.iteh.ai/catalog/standards/sist/476bd10f-2649-48f2-bc24-75c8/sist-en-12733-2001a1-2009)

[https://standards.iteh.ai/catalog/standards/sist/476bd10f-2649-48f2-bc24-](https://standards.iteh.ai/catalog/standards/sist/476bd10f-2649-48f2-bc24-75c8/sist-en-12733-2001a1-2009)

**5.2 Engine starting and stopping devices****5.2.1 Primary starting**

A switch operated by a removable key, or a similar device shall be provided unless a manual starter is the only means of engine starting.

Engine starting controls may only be outside the hand/foot reach zone defined in 5.3 if starting can only be accomplished with the cutting blade drive disengaged.

With the exception of hand cranks (see ISO 11102-1:1997 and ISO 11102-2:1997) starting devices shall be integral with the machine (e.g. recoil pull start). Loose belts, cables, etc. are not accepted.

If starting is achieved by means of a hand crank it shall be equipped with a device that disconnects the hand crank immediately when the engine starts and prevents its connection when the engine is running or kick-back during starting.

**5.2.2 Secondary starting**

If a secondary or an auxiliary starting device is provided it shall also conform to the requirements of the primary starting device.

**5.2.3 Stopping**

A stopping device shall be provided. The device shall not depend on sustained manual pressure for its continued operation.

### 5.3 Manual controls

The hand operated controls for:

- clutch;
- brakes;
- traction gearbox (within the selected range);
- reversing device;
- steering system;
- control of the engine working speed;
- hold-to-run control (see 5.5);
- blade clutch lever;
- stop control;

shall be within the “hand reach zone” (see below and Figure 1).

Gear box range, parking brake and differential lock controls may be located in the “foot reach zone” (see below and Figure 1).

Controls, other than those in the lists above, which are only used before work is started or after it is finished may be located outside the “hand/foot reach zones”.

“Hand reach zone” is the truncated hemispherical volume of radius  $R_1 = 800$  mm (see Figure 1). The centre of the hemisphere is located at point B (the midpoint of a line joining the handlebar grip ends when the grips are set to a height of 800 mm above the ground, or set to the next available lower height setting where this is not available). The flat face of the hemisphere is on the vertical plane through the line joining the handlebar grip ends. The hemisphere is truncated below by a horizontal plane positioned 450 mm above the ground.

“Foot reach zone” is the truncated hemispherical volume of radius  $R_2 = 400$  mm (see Figure 1). The centre of the hemisphere is located at point C (800 mm forward of point B and 100 mm above the ground). The flat face of the hemisphere is on the horizontal plane at 100 mm above the ground. The hemisphere is truncated by a vertical plane positioned rearward of the centre of the hemisphere at the point where it would be intersected by a horizontal plane 450 mm above the ground.

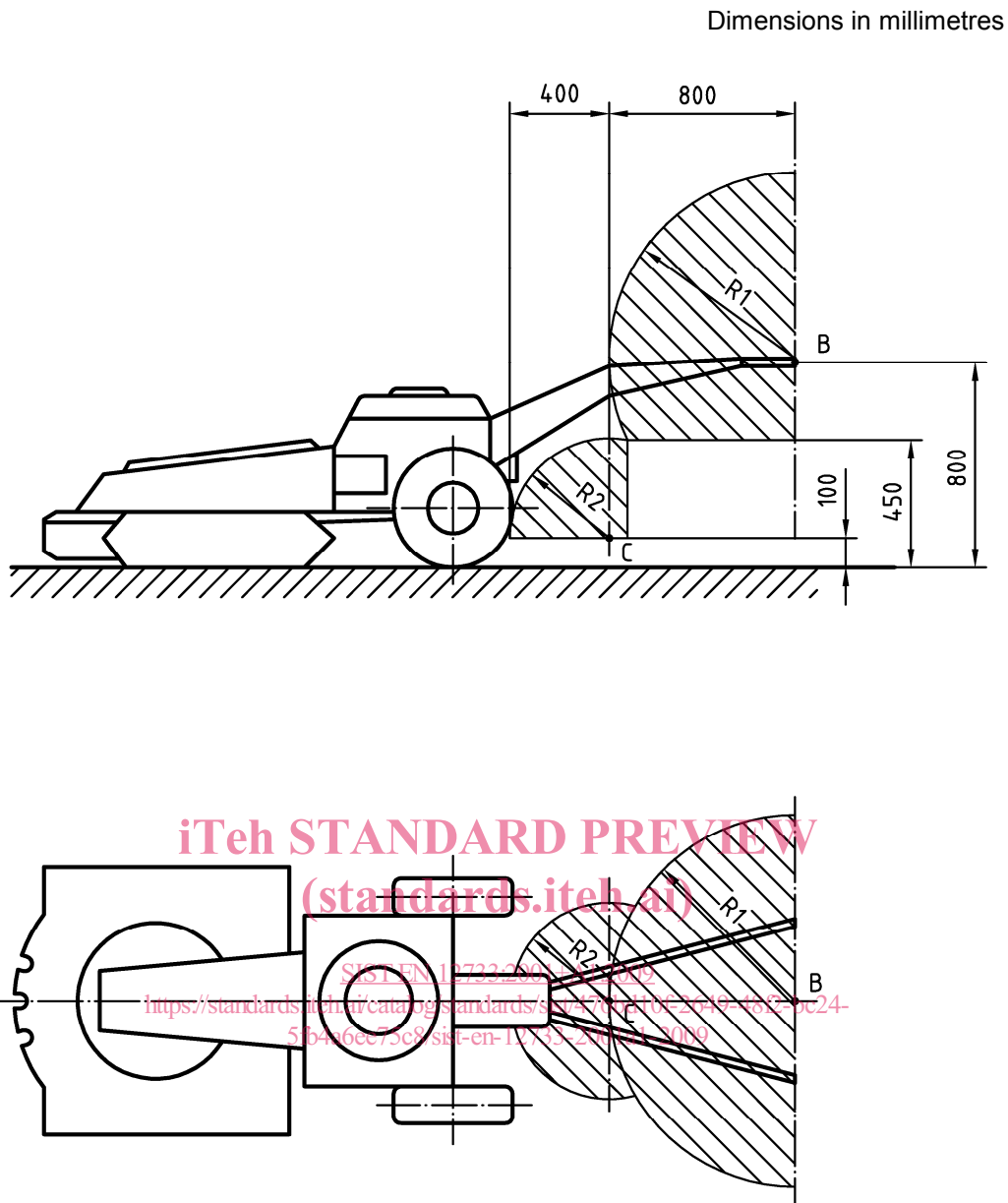

Figure 1 — Volume of “hand reach zone” and “foot reach zone”

#### 5.4 Marking of controls

Controls, whose purpose is not obvious, shall have the function, direction and/or method of operation clearly identified by a durable label or mark.

Detailed instructions on the operation of all controls shall be provided in the instruction handbook.

If symbols are used for marking controls, they shall correspond to those in ISO 3767-1:1991 and ISO 3767-3:1995.

#### 5.5 Controls of the movement of the machine and of the blade(s)

On motor mowers which are self-propelled it shall be possible to engage or disengage the traction drive when the cutting blade is operating.

The movement of the machine and the movement of the blade(s) shall be possible only by actuating hold-to-run controls. The hold-to-run controls shall be located on at least one of the handlebar grips.

Motor mowers shall be fitted with a device on the control handle which will automatically stop blade movement when the operator's hands are removed from the handle. For restarting blade movement the hold-to-run control shall require two separate actions.

The movement of the machine shall not start until the operator is able to grip both the control and the handlebar grip.

## 5.6 Reverse gear

Controls for reverse drive direction shall conform to ISO 3789-1:1982.

In all machines with reverse gear, a positive neutral position of the driving mechanism shall be provided.

Except for blades mounted behind the rear ground support point of the machine the blades and the reverse gear may operate simultaneously.

## 5.7 Handlebars

The handlebars shall be fastened to the machine so as to prevent loss of control by unintentional uncoupling from the machine while in operation.

Except in the handle park position, a positive means (latch or upper stop) shall be provided which cannot be unintentionally disengaged during normal operation of the machine.

The horizontal safety distance between the cutting blade tip circle (or the rear edge of a sickle bar mower blade assembly) and the rear end of the handlebars shall be at least 600 mm.

## 5.8 Pressurized components

Pressurized hoses shall be located or shielded so that in the event of rupture the fluid cannot be discharged directly onto the operator when in the operating position.

## 5.9 Liquid spillage

When filled to the maximum according to the manufacturer's instructions liquid containers, batteries, fuel systems, oil reservoirs, and coolant systems shall be constructed to prevent spillage for 1 min whilst the machine is tilted at 20° lateral and 30° longitudinal. Weeping at vent systems shall not be considered spillage.

## 5.10 Exhaust system

### 5.10.1 Protection against exhaust gases

The exhaust gas outlet shall be arranged in such a manner that the fumes are not directed towards any designated position of the operator.

The requirement can be fulfilled, for example, by directing the outlet of gases sideways between the angles of 60° and 120° along the axis of the machine.

**EN 12733:2001+A1:2009 (E)****5.10.2 Protection against hot surfaces****5.10.2.1 Requirements**

A guard shall be provided to prevent unintentional contact with any exposed engine exhaust components larger than 10 cm<sup>2</sup> which have a surface temperature greater than 80 °C at 20 °C ± 3 °C ambient temperature during normal starting, mounting and operation of the machine.

The temperature of the guard, when provided, shall not exceed 80 °C measured in the above described conditions.

NOTE The temperature of 80 °C is to be reviewed at the next revision of this standard taking into account any relevant values given in EN 563.

**5.10.2.2 Test equipment**

The temperature measuring equipment shall have an accuracy of ± 4 °C.

**5.10.2.3 Test method**

The engine shall be operated at its maximum operating speed until the surface temperatures stabilize.

The test shall be conducted in the shade.

If the test is conducted at an ambient temperature outside of the nominal 20 °C ± 3° C the reported temperatures shall be determined by correcting the observed temperature by adding the difference between the 20 °C and the actual test ambient temperature.

Identify the hot surface area(s) on the engine exhaust system.

When the distance between the identified hot area and the nearest control is in excess of 100 mm, cone A as shown in Figure 2 shall be used. For distances less than 100 mm between the identified hot area and the nearest control, cone B as shown in Figure 2 shall be used.

For cone A with the axis of the cone anywhere between 0° and 180° to the horizontal and with the point of the cone in a downward to horizontal direction, move the cone towards the hot surface. The cone shall not be moved in an upwards direction. When moving the cone, determine if the cone tip or conical surface of the cone makes contact with the hot surface area(s).

Cone B shall be moved in any direction.

**5.10.2.4 Test acceptance**

When tested in accordance with 5.10.2.3, using the test equipment given in 5.10.2.2 the tip or conical surface of cone A or B shall not make contact with the hot surface of the exhaust system as described in 5.10.2.1.

NOTE This method is under further study.

Dimensions in millimetres

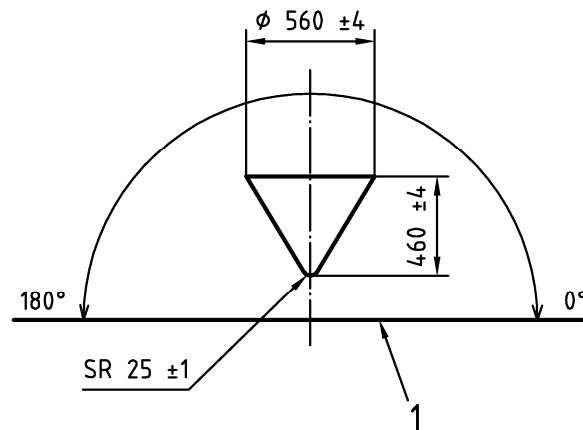
**Key**

1 Horizontal plane

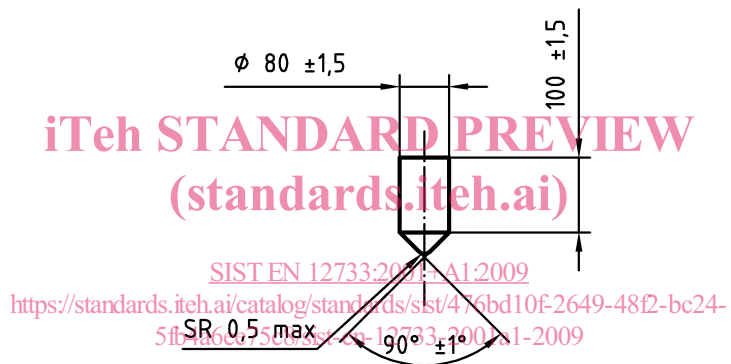
**a) Cone A****b) Cone B****Figure 2 — Test cones**