



SLOVENSKI STANDARD
SIST EN 474-1:2007+A1:2009
01-maj-2009

Stroji za zemeljska dela - Varnost - 1. del: Splošne zahteve

Earth-moving machinery - Safety - Part 1: General requirements

Erdbaumaschinen - Sicherheit - Teil 1: Allgemeine Anforderungen

Engins de terrassement - Sécurité - Partie 1: Prescriptions générales

Ta slovenski standard je istoveten z: EN 474-1:2006+A1:2009

[SIST EN 474-1:2007+A1:2009](https://standards.iteh.ai/catalog/standards/sist/4c01c802-a122-4efd-8ca8-2f29a3c19a35/sist-en-474-1-2007a1-2009)

<https://standards.iteh.ai/catalog/standards/sist/4c01c802-a122-4efd-8ca8-2f29a3c19a35/sist-en-474-1-2007a1-2009>

ICS:

53.100 Stroji za zemeljska dela Earth-moving machinery

SIST EN 474-1:2007+A1:2009 en,fr

iTeh STANDARD PREVIEW
(standards.iteh.ai)

SIST EN 474-1:2007+A1:2009

<https://standards.iteh.ai/catalog/standards/sist/4c01c802-a122-4efd-8ca8-2f29a3c19a35/sist-en-474-1-2007a1-2009>

EUROPEAN STANDARD
NORME EUROPÉENNE
EUROPÄISCHE NORM

EN 474-1:2006+A1

February 2009

ICS 53.100

Supersedes EN 474-1:2006

English Version

Earth-moving machinery - Safety - Part 1: General requirements

Engins de terrassement - Sécurité - Partie 1: Prescriptions
générales

Erdbaumaschinen - Sicherheit - Teil 1: Allgemeine
Anforderungen

This European Standard was approved by CEN on 17 April 2006 and includes Amendment 1 approved by CEN on 4 January 2009.

CEN members are bound to comply with the CEN/CENELEC Internal Regulations which stipulate the conditions for giving this European Standard the status of a national standard without any alteration. Up-to-date lists and bibliographical references concerning such national standards may be obtained on application to the CEN Management Centre or to any CEN member.

This European Standard exists in three official versions (English, French, German). A version in any other language made by translation under the responsibility of a CEN member into its own language and notified to the CEN Management Centre has the same status as the official versions.

CEN members are the national standards bodies of Austria, Belgium, Bulgaria, Cyprus, Czech Republic, Denmark, Estonia, Finland, France, Germany, Greece, Hungary, Iceland, Ireland, Italy, Latvia, Lithuania, Luxembourg, Malta, Netherlands, Norway, Poland, Portugal, Romania, Slovakia, Slovenia, Spain, Sweden, Switzerland and United Kingdom.

IT IS STANDARD PREVIEW
(standards.iteh.ai)

<https://standards.iteh.ai/catalog/standards/sist/4c01c802-a122-4efd-8ca8-2f29a3c19a35/sist-en-474-1-2007a1-2009>



EUROPEAN COMMITTEE FOR STANDARDIZATION
COMITÉ EUROPÉEN DE NORMALISATION
EUROPÄISCHES KOMITEE FÜR NORMUNG

Management Centre: Avenue Marnix 17, B-1000 Brussels

Contents

	Page
Foreword.....	3
Introduction	5
1 Scope	6
2 Normative references	6
3 Terms and definitions	9
4 List of significant hazards	11
5 Safety requirements and/or measures	11
6 Verification of safety requirements/measures.....	30
7 Information for use	30
Annex A (normative) List of significant hazards	35
Annex B (normative) Requirements for attachment and attachment bracket	39
Annex C (informative) Requirements for no-text safety signs	41
Annex D (normative) Requirements for elevating operator's station.....	43
Annex E (normative) Requirements for lifting device(s) used for object handling application.....	45
Annex F (normative) Requirements for earth-moving machinery used in underground working in non-explosive atmosphere	52
Annex ZA (informative) Relationship between this European Standard and the Essential Requirements of EU Directive 98/37/EC	54
Annex ZB (informative) A1 Relationship between this European Standard and the Essential Requirements of EU Directive 2006/42/EC A1.....	55
Bibliography	56

Foreword

This document (EN 474-1:2006+A1:2009) has been prepared by Technical Committee CEN/TC 151 "Construction equipment and building material machines — Safety", the secretariat of which is held by DIN.

This European Standard shall be given the status of a national standard, either by publication of an identical text or by endorsement, at the latest by August 2009, and conflicting national standards shall be withdrawn at the latest by December 2009.

This document includes Amendment 1, approved by CEN on 2009-01-04.

This European Standard supersedes \square_{A1} EN 474-1:2006 \square_{A1} .

The start and finish of text introduced or altered by amendment is indicated in the text by tags \square_{A1} \square_{A1} .

This document has been prepared under a mandate given to CEN by the European Commission and the European Free Trade Association, and supports essential requirements of EU Directive.

\square_{A1} For relationship with EU Directive(s), see informative Annexes ZA and ZB, which are integral parts of this document. \square_{A1}

EN 474 "Earth-moving machinery — Safety" comprises the following parts:

- Part 1: General requirements
- Part 2: Requirements for tractor-dozers
- Part 3: Requirements for loaders
- Part 4: Requirements for backhoe-loaders
- Part 5: Requirements for hydraulic excavators
- Part 6: Requirements for dumpers
- Part 7: Requirements for scrapers
- Part 8: Requirements for graders
- Part 9: Requirements for pipe-layers
- Part 10: Requirements for trenchers
- Part 11: Requirements for earth and landfill compactors
- Part 12: Requirements for cable excavators

For specific machines covered by other parts of the standard, this European Standard is intended for use in combination with relevant other parts of the series.

EN 474-1:2006+A1:2009 (E)

According to the CEN/CENELEC Internal Regulations, the national standards organizations of the following countries are bound to implement this European Standard: Austria, Belgium, Bulgaria, Cyprus, Czech Republic, Denmark, Estonia, Finland, France, Germany, Greece, Hungary, Iceland, Ireland, Italy, Latvia, Lithuania, Luxembourg, Malta, Netherlands, Norway, Poland, Portugal, Romania, Slovakia, Slovenia, Spain, Sweden, Switzerland and United Kingdom.

iTeh STANDARD PREVIEW (standards.iteh.ai)

SIST EN 474-1:2007+A1:2009

<https://standards.iteh.ai/catalog/standards/sist/4c01c802-a122-4efd-8ca8-2f29a3c19a35/sist-en-474-1-2007a1-2009>

Introduction

This part of EN 474 is a type C standard as stated in EN ISO 12100-1:2003.

The machinery concerned and the extent to which hazards, hazardous situations and events are covered are indicated in the scope of this European Standard.

When provisions of this type C standard are different from those which are stated in type A or B standards, the provisions of this type C standard take precedence over the provisions of the other standards, for machines that have been designed and built according to the provisions of this type C standard.

iTeh STANDARD PREVIEW (standards.iteh.ai)

[SIST EN 474-1:2007+A1:2009](https://standards.iteh.ai/catalog/standards/sist/4c01c802-a122-4efd-8ca8-2f29a3c19a35/sist-en-474-1-2007a1-2009)

<https://standards.iteh.ai/catalog/standards/sist/4c01c802-a122-4efd-8ca8-2f29a3c19a35/sist-en-474-1-2007a1-2009>

EN 474-1:2006+A1:2009 (E)**1 Scope**

This part of EN 474 specifies the general safety requirements for earth-moving machinery¹⁾ described in EN ISO 6165:2006, except rollers and horizontal directional drill.

NOTE 1 Rollers are covered by EN 500.

NOTE 2 Horizontal directional drills are covered by EN 791.

This part also applies to derivative machinery (see 3.1.2) designed primarily for use with equipment to loosen, pick-up, move, transport, distribute and grade earth and rock.

This part gives the common safety requirements for earth-moving machinery families and is intended to be used in conjunction with one of the EN 474 parts 2 to 12. These machine specific parts (EN 474-2 to -12) do not repeat the requirements from **A1** EN 474-1:2006+A1:2009 **A1**, but add or replace the requirements for the family in question.

NOTE 3 The requirements specified in this part of the standard are common to two or more families of earth-moving machinery.

Specific requirements in EN 474 parts 2 to 12 take precedence over the respective requirements of **A1** EN 474-1:2006+A1:2009 **A1**.

For multipurpose machinery the parts of the standard that cover the specific functions and applications have to be used e.g. a compact loader also used as a trencher shall use the relevant requirements of EN 474 parts 1, 3 and 10.

The standard also covers general requirements for attachments intended to be used with earth moving machine families covered in the scope.

A1 Except for part 12 this European Standard does not deal **A1** with the electrical hazards related to the main circuits and drives of machinery when the principal source of energy is electrical.

A1 This European Standard does not deal with towing of trailers. **A1**

This European Standard deals with all significant hazards, hazardous situations and events relevant to earth-moving machinery, when used as intended and under conditions of misuse which are reasonably foreseeable by the manufacturer (see Clause 4). This European Standard specifies the appropriate technical measures to eliminate or reduce risks arising from the significant hazards, hazardous situations and events during commissioning, operation and maintenance of earth-moving machinery.

This European Standard is not applicable to earth moving machines, which are manufactured before the date of publication of this European Standard by CEN.

2 Normative references

The following referenced documents are indispensable for the application of this European Standard. For dated references, only the edition cited applies. For undated references, the latest edition of the referenced document (including any amendments) applies.

EN 286-2:1992, *Simple unfired pressure vessels designed to contain air or nitrogen — Part 2: Pressure vessels for air braking and auxiliary systems for motor vehicles and their trailers*

1) For travelling on public roads the national traffic regulations apply until harmonised requirements are available. (A CEN-standard is under preparation)

EN 287-1:2004, *Qualification test of welders — Fusion welding — Part 1: Steels*

A1 deleted text **A1**

EN 982:1996, *Safety of machinery — Safety requirements for fluid power systems and their components — Hydraulics*

EN 1677-2:2000, *Components for slings — Safety — Part 2: Forged steel lifting hooks with latch, Grade 8*

A1 EN 12643:1997+A1:2008 **A1**, *Earth-moving machinery — Rubber-tyred machines — Steering requirements (ISO 5010:1992, modified)*

EN 13309:2000, *Construction machinery — Electromagnetic compatibility of machines with internal electrical power supply*

A1 deleted text **A1**

EN 60529:1991, *Degrees of protection provided by enclosures (IP code) (IEC 60529:1989)*

EN 61310-1:1995, *Safety of machinery — Indication, marking and actuation — Part 1: Requirements for visual, auditory and tactile signals (IEC 61310-1:1995)*

EN ISO 2860:1999, *Earth-moving machinery — Minimum access dimensions (ISO 2860:1992)*

EN ISO 2867:2006, *Earth-moving machinery — Access systems (ISO 2867:2006)*

A1 EN ISO 3411:2007, *Earth-moving machinery — Physical dimensions of operators and minimum operator space envelope (ISO 3411:2007)* **A1**

A1 EN ISO 3449:2008, *Earth-moving machinery — Falling-object protective structures — Laboratory tests and performance requirements (ISO 3449:2005)* **A1**

EN ISO 3450:1996, *Earth-moving machinery — Braking systems of rubber-tyred machines — System and performance requirements and test procedures (ISO 3450:1996)*

EN ISO 3457:2003, *Earth-moving machinery — Guards — Definitions and requirements (ISO 3457:2003)*

A1 EN ISO 3471:2008, *Earth-moving machinery — Roll-over protective structures — Laboratory tests and performance requirements (ISO 3471:2008)* **A1**

EN ISO 4871:1996, *Acoustics — Declaration and verification of noise emission values of machinery and equipment (ISO 4871:1996)*

EN ISO 5353:1998, *Earth-moving machinery, and tractors and machinery for agriculture and forestry — Seat index point (ISO 5353:1995)*

EN ISO 6165:2006, *Earth-moving machinery — Basic types — **A1** deleted text **A1** Identification and terms and definitions (ISO 6165:2006)*

EN ISO 6682:1995, *Earth-moving machinery — Zones of comfort and reach for controls (ISO 6682:1986 including Amendment 1:1989)*

EN ISO 6683:2005, *Earth-moving machinery — Seat belts and seat belt anchorages — Performance requirements and tests (ISO 6683:2005)*

EN ISO 7096:2000, *Earth-moving machinery — Laboratory evaluation of operator seat vibration (ISO 7096:2000)*

EN 474-1:2006+A1:2009 (E)

Ⓐ₁ EN ISO 11688-1:1998, *Acoustics — Recommended practice for the design of low-noise machinery and equipment — Part 1: Planning (ISO/TR 11688-1:1995)* Ⓐ₁

EN ISO 12100-1:2003, *Safety of machinery — Basic concepts, general principles for design — Part 1: Basic terminology, methodology (ISO 12100-1:2003)*

EN ISO 12100-2:2003, *Safety of machinery — Basic concepts, general principles for design — Part 2: Technical principles (ISO 12100-2:2003)*

EN ISO 13732-1:2006, *Ergonomics of the thermal environment - Methods for the assessment of human responses to contact with surfaces - Part 1: Hot surfaces (ISO 13732-1:2006)*

Ⓐ₁ EN ISO 13849-1:2008, *Safety of machinery — Safety-related parts of control systems — Part 1: General principles for design (ISO 13849-1:2006)* Ⓐ₁

ISO 3795:1989, *Road vehicles, and tractors and machinery for agriculture and forestry — Determination of burning behaviour of interior materials*

ISO 3864-1:2002, *Graphical symbols — Safety colours and safety signs — Part 1: Design principles for safety signs in work places and public areas*

ISO 3864-2:2004, *Graphical symbols — Safety colours and safety signs — Part 2: Design principles for product safety labels*

Ⓐ₁ ISO 4250-3:2006 Ⓐ₁, *Earth-mover tyres and rims — Part 3: Rims*

ISO 5006:2006, *Earth-moving machinery — Operator's field of view — Test method and performance criteria*

ISO 6011:2003, *Earth-moving machinery — Visual display of machine operation*

ISO 6014:1986, *Earth-moving machinery — Determination of ground speed*

ISO 6016:1998, *Earth-moving machinery — Methods of measuring the masses of whole machines, their equipment and components*

Ⓐ₁ ISO 6395:2008, *Earth-moving machinery — Determination of sound power level — Dynamic test conditions* Ⓐ₁

Ⓐ₁ ISO 6396:2008 Ⓐ₁, *Earth-moving machinery — Determination of emission sound pressure level at operator's position — Dynamic test conditions*

ISO 6405-1:2004, *Earth-moving machinery — Symbols for operator controls and other displays — Part 1: Common symbols*

ISO 6405-2:1993, *Earth-moving machinery — Symbols for operator controls and other displays — Part 2: Specific symbols for machines, equipment and accessories*

ISO 6749:1984, *Earth-moving machinery — Preservation and storage*

ISO 8643:1997, *Earth-moving machinery — Hydraulic excavator and backhoe loader boom-lowering control device — Requirements and tests*

ISO 9533:1989, *Earth-moving machinery — Machine mounted forward and reverse audible warning alarm — Sound test method*

Ⓐ₁ ISO/DIS 10263-2:2007, *Earth-moving machinery — Operator enclosure environment — Part 2: Air filter element test method* Ⓐ₁

ISO/DIS 10263-3:2007, *Earth-moving machinery — Operator enclosure environment — Part 3: Pressurization test method*

ISO/DIS 10263-4:2007, *Earth-moving machinery — Operator enclosure environment — Part 4: Heating, ventilating and air conditioning (HVAC) test method and performance*

ISO 10264:1990, *Earth-moving machinery — Key-locked starting systems*

ISO 10265:2008, *Earth-moving machinery — Crawler machines — Performance requirements and test procedures for braking systems*

ISO 10532:1995, *Earth-moving machinery — Machine-mounted retrieval device — Performance requirements*

ISO 10533:1993, *Earth-moving machinery — Lift-arm support devices.*

ISO 10570:2004, *Earth-moving machinery — Articulated frame lock — Performance requirements*

ISO 10968:2004, *Earth-moving machinery — Operator's controls*

ISO 11112:1995, *Earth-moving machinery — Operator's seat — Dimensions and requirements*

ISO 11862:1993, *Earth-moving machinery — Auxiliary starting aid electrical connector*

ISO 12508:1994, *Earth-moving machinery — Operator station and maintenance areas — Bluntness of edges*

ISO 12509:2004, *Earth-moving machinery — Lighting, signalling and marking lights, and reflex-reflector devices*

ISO 13333:1994, *Earth-moving machinery — Dumper body support and operator's cab tilt support devices*

ISO 14396:2002, *Reciprocating internal combustion engines — Determination and method for the measurement of engine power — Additional requirements for exhaust emission tests in accordance with ISO 8178*

ISO 14401-1:2004, *Earth-moving machinery — Field of vision of surveillance and rear-view mirrors — Part 1: Test methods*

ISO 14401-2:2004, *Earth-moving machinery — Field of vision of surveillance and rear-view mirrors — Part 2: Performance criteria*

ISO 15817:2005, *Earth-moving machinery — Safety requirements for remote operator control*

ISO 15998:2008, *Earth-moving machinery — Machine-control systems (MCS) using electronic components — Performance criteria and tests for functional safety*

3 Terms and definitions

For the purposes of this European Standard, the terms and definitions given in EN ISO 12100-1:2003 and the following apply.

Earth-moving machinery and their families are defined in EN ISO 6165:2006.

NOTE Definitions used in EN and ISO standards referred to in this European Standard are also valid for this document.

EN 474-1:2006+A1:2009 (E)**3.1****earth-moving machinery**

self-propelled or towed machine on wheels, crawler or legs, having equipment and/or attachment (working tool), primarily designed to perform excavating, loading, transporting, spreading, compacting or trenching of earth, rock or similar materials

NOTE An earth-moving machine is normally operated by a ride-on operator but can also be remote – or pedestrian – controlled.

3.1.1**compact machine**

earth-moving machinery having an operating mass (see ISO 6016:1998) of 4 500 kg or less, or compact excavators having an operating mass (see ISO 6016:1998) of 6 000 kg or less

3.1.2**derivative machinery**

earth-moving machinery fitted with equipment and/or attachment which modifies its function

NOTE For the European Economic Area (EEA) the equipment or attachment or a piece of equipment as defined in ISO 6016:1998 which modifies the function of the machine and is intended to be assembled by the operator can be "interchangeable equipment" in the sense of the Machinery Directive.

3.2**attachment (working tool)**

component or assembly of components, which can be mounted onto the base machine or equipment (see ISO 6746-1:2003, ISO 6746-2:2003 and ISO 6016:1998) for a specific use

3.3**attachment bracket**

device to facilitate quick interchange of attachments

3.4**object handling**

application of earth-moving machinery comprising lifting, lowering and transporting of a load by use of lifting accessories, whereby the assistance of a person or the operator of the machine is required for hooking, unhooking or stabilising (whilst transporting) the load

NOTE 1 If the load is picked-up by a self-acting device and no assistance of a person is required for hooking, unhooking and stabilising the load, this work is considered as usual earth-moving application.

NOTE 2 Lifting accessories are, e.g., wire ropes, chains or textile straps; loads in object handling application are, e.g., pipes, vessels; self-acting devices are, e.g., grabs, clamshell buckets, log clamps, vacuum lifting device, magnetic plate and fork.

3.5**maximum rated operating/lift capacity in object handling**

maximum capacity which can be lifted at least in one position of the working range as specified by the manufacturer (e.g. on the rated object handling capacity table) in the most stable configuration (e.g. outriggers down)

NOTE The term "rated operating capacity" is defined in ISO 14397-1:2002 and used in [EN 474-3:2006+A1:2009](#) and [EN 474-4:2006+A1:2009](#). The term "rated lift capacity" is defined in ISO 10567:1992 and used in [EN 474-5:2006+A1:2009](#). Both terms are equivalent.

4 List of significant hazards

See Annex A.

NOTE Annex A (normative) contains all the significant hazards, hazardous situations and events, as far as they are dealt with in this European Standard, identified by risk assessment as common to two or more machinery families and which require action to eliminate or reduce the risk.

5 Safety requirements and/or measures

5.1 General

Earth-moving machinery shall comply with the safety requirements and/or protective measures of this European Standard, as far as not modified by requirements of the relevant specific part of the standard series. In addition, the machine shall be designed according to the principles of EN ISO 12100-1:2003 and EN ISO 12100-2:2003 for hazards relevant but not significant which are not dealt with by this European Standard.

5.2 Access

5.2.1 General requirements

Adequate access systems shall be provided to the operator's station and areas where routine maintenance has to be performed by the operator as described in the operator's manual. Access system shall comply with EN ISO 2867:2006.

Effect of mud on the means of access shall be minimised by adequate design.

5.2.2 Access to articulated machines

On machines with articulated frames and in the fully articulated steering position, a minimum clearance of 150 mm for the lower limbs shall be provided $\langle A_1 \rangle$ between firm structures and components with $\langle A_1 \rangle$ relative movement in the path of the access systems to the operator's station, as illustrated in Figure 1.

Dimensions in millimetres

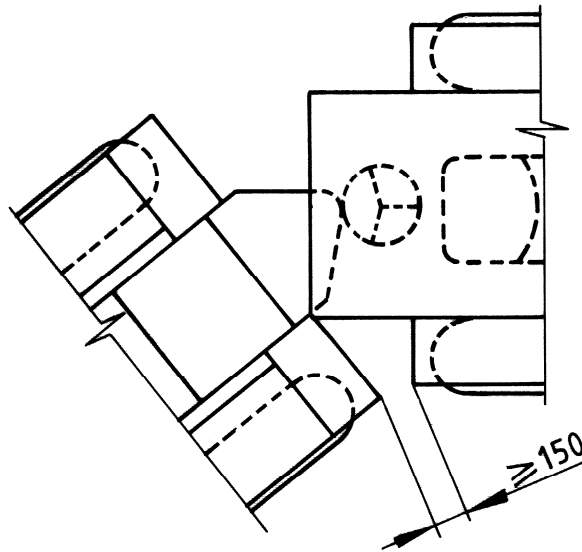

Figure 1 — Minimum clearance of lower limbs at access to the operator's station on machines with articulated steering

5.2.3 Access system on crawler machines with step(s)

SIST EN 474-1:2007+A1:2009

Access step(s) integrated in the track frame shall meet the requirements as stated below (see also Figure 2).

2f29a3c19a35/sist-en-474-1-2007a1-2009

A step of an access system can be retracted under an angle of $\leq 15^\circ$, if at least the basic dimension of riser height dimension B, and the tread depth F_1 according to Figure 1 and Table 1 of EN ISO 2867:2006 is met, measured from the outer edges of the track shoes.

In such a case, taken into account the limited view during egress, the step width shall be at least as wide as the minimum in accordance with Table 1 of EN ISO 2867:2006.

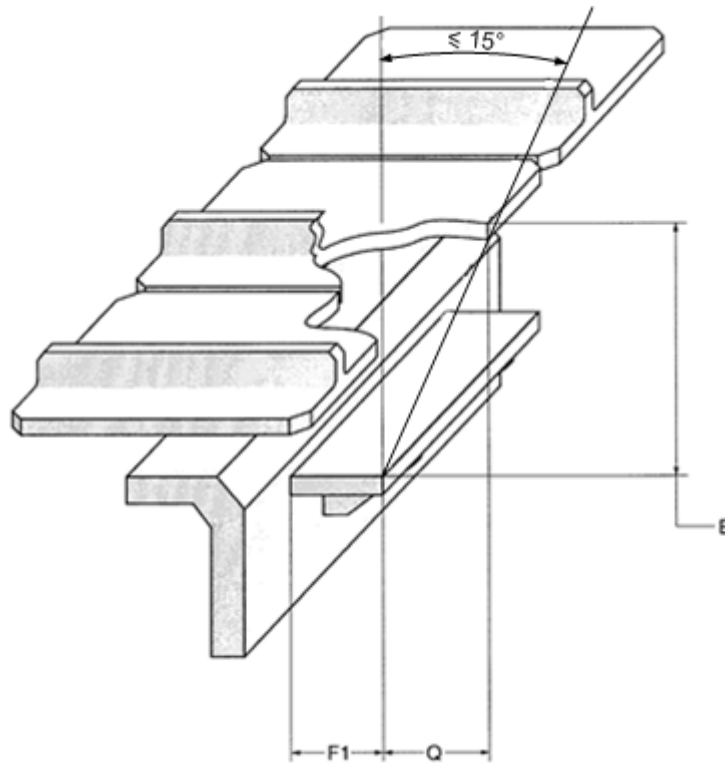

iTeh STANDARD PREVIEW (standards.iteh.ai)

Key

B ≤ 400 mm

F1 ≥ 130 mm

Q maximum retraction of a step [SIST EN 474-1:2007+A1:2009](https://standards.iteh.ai/catalog/standards/sist/4c01c802-a122-4efd-8ca8-2f29ac19a55/sist-en-474-1-2007/a1-2009)

<https://standards.iteh.ai/catalog/standards/sist/4c01c802-a122-4efd-8ca8-2f29ac19a55/sist-en-474-1-2007/a1-2009>

Figure 2 — Dimensions access step

5.3 Operator's station

5.3.1 General requirements

5.3.1.1 Machinery equipment

A1) The driving position of ride-on drivers shall be designed and constructed in such a way that a driver's cab may be fitted, provided this does not increase the risk and there is room for it. **A1)**

Machines with an operating mass less than 1 500 kg are not required to have a cab.

Machines with an operating mass greater than or equal to 1 500 kg shall be equipped with a cab, unless the foreseeable adverse weather conditions allow all-year operation without a cab (negotiated between manufacturer and user).

Machines shall be equipped with a cab and a contamination protective system if the machine is intended for use in unhealthy environments, e.g. contaminated areas (negotiated between manufacturer and user). See 5.14.1.

If a hazard due to projection of splinters exists, e.g. operation with a hydraulic- or demolition-hammer, an adequate protection such as bullet proof glass, mesh guard or an equivalent protection is required.