



SLOVENSKI STANDARD
SIST EN ISO 3690:2001
01-december-2001

JUfYbY]b'gcfXb]dcgld_]!'8c`c Yj UbY'j cX]_Uj 'Zf]fb] `cV`c b] `j Uf] `fIGC
' * - \$.&\$\$L

Welding and allied processes - Determination of hydrogen content in ferritic arc weld metal (ISO 3690:2000)

Schweißen und verwandte Prozesse - Bestimmung des diffusiblen Wasserstoffgehaltes im ferritischen Schweißgut (ISO/FDIS 3690:2000)

Soudage et techniques connexes - Détermination de la teneur en hydrogene dans la métal fondu pour le soudage a l'arc des aciers ferritiques (ISO 3690:2000)

<https://standards.iteh.ai/catalog/standards/sist/e9cea20f-c0e7-4dbe-b3c5-85789eab7d67/sist-en-iso-3690-2001>

Ta slovenski standard je istoveten z: EN ISO 3690:2000

ICS:

25.160.40 Varjeni spoji in vari Welded joints

SIST EN ISO 3690:2001 en

iTeh STANDARD PREVIEW
(standards.iteh.ai)

SIST EN ISO 3690:2001

<https://standards.iteh.ai/catalog/standards/sist/e9cea20f-c0e7-4dbe-b3c5-85789eab7d67/sist-en-iso-3690-2001>

EUROPEAN STANDARD
NORME EUROPÉENNE
EUROPÄISCHE NORM

EN ISO 3690

December 2000

ICS 02.016.40

English version

Welding and allied processes - Determination of hydrogen content in ferritic arc weld metal (ISO 3690:2000)

Soudage et techniques connexes - Détermination de la teneur en hydrogène dans la métal fondu pour le soudage à l'arc des aciers ferritiques (ISO 3690:2000)

Schweißen und verwandte Prozesse - Bestimmung des diffusiblen Wasserstoffgehaltes im ferritischen Schweißgut (ISO/FDIS 3690:2000)

This European Standard was approved by CEN on 15 December 2000.

CEN members are bound to comply with the CEN/CENELEC Internal Regulations which stipulate the conditions for giving this European Standard the status of a national standard without any alteration. Up-to-date lists and bibliographical references concerning such national standards may be obtained on application to the Management Centre or to any CEN member.

This European Standard exists in three official versions (English, French, German). A version in any other language made by translation under the responsibility of a CEN member into its own language and notified to the Management Centre has the same status as the official versions.

CEN members are the national standards bodies of Austria, Belgium, Czech Republic, Denmark, Finland, France, Germany, Greece, Iceland, Ireland, Italy, Luxembourg, Netherlands, Norway, Portugal, Spain, Sweden, Switzerland and United Kingdom.

[SIST EN ISO 3690:2001](https://standards.iteh.ai/catalog/standards/sist/e9cea20f-c0e7-4dbe-b3c5-85789eab7d67/sist-en-iso-3690-2001)

<https://standards.iteh.ai/catalog/standards/sist/e9cea20f-c0e7-4dbe-b3c5-85789eab7d67/sist-en-iso-3690-2001>



EUROPEAN COMMITTEE FOR STANDARDIZATION
COMITÉ EUROPÉEN DE NORMALISATION
EUROPÄISCHES KOMITEE FÜR NORMUNG

Management Centre: rue de Stassart, 36 B-1050 Brussels

Page 2
EN ISO 3690:2000

Foreword

The text of the International Standard ISO 3690:2000 has been prepared by Technical Committee ISO/TC 44 "Welding and allied processes" in collaboration with Technical Committee CEN/TC 121 "Welding", the secretariat of which is held by DS.

This European Standard shall be given the status of a national standard, either by publication of an identical text or by endorsement, at the latest by June 2001, and conflicting national standards shall be withdrawn at the latest by June 2001.

According to the CEN/CENELEC Internal Regulations, the national standards organizations of the following countries are bound to implement this European Standard: Austria, Belgium, Czech Republic, Denmark, Finland, France, Germany, Greece, Iceland, Ireland, Italy, Luxembourg, Netherlands, Norway, Portugal, Spain, Sweden, Switzerland and the United Kingdom.

Endorsement notice

The text of the International Standard ISO 3690:2000 was approved by CEN as a European Standard without any modification.

iTeh STANDARD PREVIEW
(standards.iteh.ai)

[SIST EN ISO 3690:2001](https://standards.iteh.ai/catalog/standards/sist/e9cea20f-c0e7-4dbe-b3c5-85789eab7d67/sist-en-iso-3690-2001)

<https://standards.iteh.ai/catalog/standards/sist/e9cea20f-c0e7-4dbe-b3c5-85789eab7d67/sist-en-iso-3690-2001>

INTERNATIONAL STANDARD

**ISO
3690**

Second edition
2000-12-15

Welding and allied processes — Determination of hydrogen content in ferritic steel arc weld metal

*Soudage et techniques connexes — Détermination de la teneur en
hydrogène dans le métal fondu pour le soudage à l'arc des aciers
ferritiques*

iTeh STANDARD PREVIEW
(standards.iteh.ai)

[SIST EN ISO 3690:2001](https://standards.iteh.ai/catalog/standards/sist/e9cea20f-c0e7-4dbe-b3c5-85789eab7d67/sist-en-iso-3690-2001)

<https://standards.iteh.ai/catalog/standards/sist/e9cea20f-c0e7-4dbe-b3c5-85789eab7d67/sist-en-iso-3690-2001>



Reference number
ISO 3690:2000(E)

© ISO 2000

ISO 3690:2000(E)

PDF disclaimer

This PDF file may contain embedded typefaces. In accordance with Adobe's licensing policy, this file may be printed or viewed but shall not be edited unless the typefaces which are embedded are licensed to and installed on the computer performing the editing. In downloading this file, parties accept therein the responsibility of not infringing Adobe's licensing policy. The ISO Central Secretariat accepts no liability in this area.

Adobe is a trademark of Adobe Systems Incorporated.

Details of the software products used to create this PDF file can be found in the General Info relative to the file; the PDF-creation parameters were optimized for printing. Every care has been taken to ensure that the file is suitable for use by ISO member bodies. In the unlikely event that a problem relating to it is found, please inform the Central Secretariat at the address given below.

iTeh STANDARD PREVIEW (standards.iteh.ai)

SIST EN ISO 3690:2001

<https://standards.iteh.ai/catalog/standards/sist/e9cea20f-c0e7-4dbe-b3c5-85789eab7d67/sist-en-iso-3690-2001>

© ISO 2000

All rights reserved. Unless otherwise specified, no part of this publication may be reproduced or utilized in any form or by any means, electronic or mechanical, including photocopying and microfilm, without permission in writing from either ISO at the address below or ISO's member body in the country of the requester.

ISO copyright office
Case postale 56 • CH-1211 Geneva 20
Tel. + 41 22 749 01 11
Fax + 41 22 749 09 47
E-mail copyright@iso.ch
Web www.iso.ch

Printed in Switzerland

Contents

Page

Foreword.....	iv
Introduction	v
1 Scope	1
2 Normative reference	1
3 Test procedures	1
3.1 Production of weld specimens.....	1
3.2 Welding procedures for the production of weld specimens.....	5
3.3 Measurement of hydrogen in the test weld.....	13
Annex A (informative) Older methods of measurement.....	19
Bibliography	20

iTeh STANDARD PREVIEW
(standards.iteh.ai)

[SIST EN ISO 3690:2001](https://standards.iteh.ai/catalog/standards/sist/e9cea20f-c0e7-4dbe-b3c5-85789eab7d67/sist-en-iso-3690-2001)

<https://standards.iteh.ai/catalog/standards/sist/e9cea20f-c0e7-4dbe-b3c5-85789eab7d67/sist-en-iso-3690-2001>

ISO 3690:2000(E)**Foreword**

ISO (the International Organization for Standardization) is a worldwide federation of national standards bodies (ISO member bodies). The work of preparing International Standards is normally carried out through ISO technical committees. Each member body interested in a subject for which a technical committee has been established has the right to be represented on that committee. International organizations, governmental and non-governmental, in liaison with ISO, also take part in the work. ISO collaborates closely with the International Electrotechnical Commission (IEC) on all matters of electrotechnical standardization.

International Standards are drafted in accordance with the rules given in the ISO/IEC Directives, Part 3.

Draft International Standards adopted by the technical committees are circulated to the member bodies for voting. Publication as an International Standard requires approval by at least 75 % of the member bodies casting a vote.

Attention is drawn to the possibility that some of the elements of this International Standard may be the subject of patent rights. ISO shall not be held responsible for identifying any or all such patent rights.

International Standard ISO 3690 was prepared in collaboration with the International Institute of Welding which has been approved by the ISO Council as an international standardizing body in the field of welding.

This second edition cancels and replaces the first edition (ISO 3690:1977), which has been technically revised.

Annex A of this International Standard is for information only.

ITC STANDARD PREVIEW
(standards.iteh.ai)
SIST EN ISO 3690:2001
<https://standards.iteh.ai/catalog/standards/sist/e9cea20f-c0e7-4dbe-b3c5-85789eab7d67/sist-en-iso-3690-2001>

Introduction

During welding processes hydrogen is absorbed by the weld pool from the arc atmosphere. During cooling some of this hydrogen escapes from the solid bead by diffusion but some also diffuses into the HAZ and parent metal. The amount which does so depends on several factors such as original amount absorbed, the size of the weld and the time-temperature conditions of cooling. Other factors being equal, the more hydrogen present in the weld the greater the risk of cracking. The principal sources of hydrogen in welding are:

- moisture contained in and picked up by electrode coatings and fluxes;
- other hydrogenous materials which may break down in the heat of the arc;
- oil, dirt and grease on the plate surface or trapped in the surface layers of welding wires;
- atmospheric moisture during welding.

Measurements of weld hydrogen level therefore provide the means of deciding the degree to which a given welding consumable is introducing hydrogen to the weld pool. They may thus help to categorize the sources of hydrogen and classify different welding consumables. In addition, such measurements provide a starting point for calculating preheating temperatures and temperatures of heat treatment to remove hydrogen after welding.

Hydrogen is unlike other elements in ferritic weld metal in that it diffuses rapidly at normal room temperatures and some of it may be lost before an analysis can be made. This, coupled with the fact that the concentrations to be measured are usually at the parts per million level, means that special sampling and analysis procedures are needed. In order that results be comparable between different laboratories and can be used to develop hydrogen control procedures, some international standardization of these sampling and analysis methods is necessary.

It has become clear from work within the International Institute of Welding that the same sampling and analysis procedure can be used with minor modifications to deal with a number of fusion welding procedures and also for purposes other than the simple classification of consumables. The purpose of this document is therefore to define a standardized procedure of sampling and analysis of weld metal for the determination of hydrogen. The essential features of the International Standard provide for the production of a weld specimen in the form of a rapidly quenched single bead, and the procedure is described in 3.1; 3.2 of this International Standard gives details of the procedures to be used when different welding processes are under investigation. The specimen obtained in this way is then compatible with the recommended analytical techniques specified in 3.3.

There are two principal ways in which this International Standard is intended to be used:

- a) To provide information on the levels of weld hydrogen arising from the use of consumables in specific states (e.g. wet or dry), or as a result of the use of specific welding parameters (e.g. different current levels). For such purposes the method can be applied with a variety of welding parameters and states of consumable, and these will be chosen on each occasion in order to provide the specific information sought. It is important however to state such conditions when results are reported so that misunderstandings can be avoided.
- b) To enable consumables to be classified and to assist in quality control. In such cases consumables have to be treated in like manner — i.e. with fixed conditions of drying temperature and time, welding current and so on.

It is understood that mercury is a hazardous substance, and that its use may be restricted in some countries. It should be recognized that this International Standard provides a reference method against which all other methods are to be calibrated. Once a proper calibration of an alternate method against this reference method is established, normal testing can be conducted with the alternate method. Then the reference method need only be used in rare instances, such as for checking calibration or in cases of dispute.

iTeh STANDARD PREVIEW
(standards.iteh.ai)

SIST EN ISO 3690:2001

<https://standards.iteh.ai/catalog/standards/sist/e9cea20f-c0e7-4dbe-b3c5-85789eab7d67/sist-en-iso-3690-2001>

Welding and allied processes — Determination of hydrogen content in ferritic steel arc weld metal

1 Scope

This International Standard specifies the sampling and analytical procedure for the determination of diffusible and residual hydrogen in ferritic weld metal arising from the welding of ferritic steel using arc welding processes with filler metal. Collection of the hydrogen over mercury is the primary method. Provided that the weld specimen size is maintained within limits dictated by the size of the test block, variations in welding parameters are permissible in order to investigate the effect of such variables on the weld hydrogen content. The techniques described in this International Standard constitute a reference method which should be used in cases of dispute.

2 Normative reference

The following normative document contains provisions which, through reference in this text, constitute provisions of this International Standard. For dated references, subsequent amendments to, or revisions of, any of these publications do not apply. However, parties to agreements based on this International Standard are encouraged to investigate the possibility of applying the most recent edition of the normative document indicated below. For undated references, the latest edition of the normative document referred to applies. Members of ISO and IEC maintain registers of currently valid International Standards.

ISO 14175, *Welding consumables — Shielding gases for arc welding and cutting.*

3 Test procedures

3.1 Production of weld specimens

3.1.1 Principle

The welding process to be tested is used to deposit a single weld bead which is rapidly quenched and subsequently stored at -78 °C or lower until required for preparation and analysis.

3.1.2 Welding fixture

A copper welding jig for heat inputs up to 2 kJ/mm , which may be water cooled, is shown in Figure 1. It is designed to promote the proper alignment and clamping of the test piece assembly by means of the single clamping unit which is used with a ring spanner or other suitable means. See 3.1.4 for evidence of proper alignment and clamping. A welding jig without water cooling may be used as long as the same dimensions are retained and as long as the temperature is controlled in the manner described in 3.1.4 below.

The welding jig shown in Figure 2 will allow the production of test welds with a heat input greater than 2 kJ/mm and up to about 3 kJ/mm .

Dimensions in millimetres

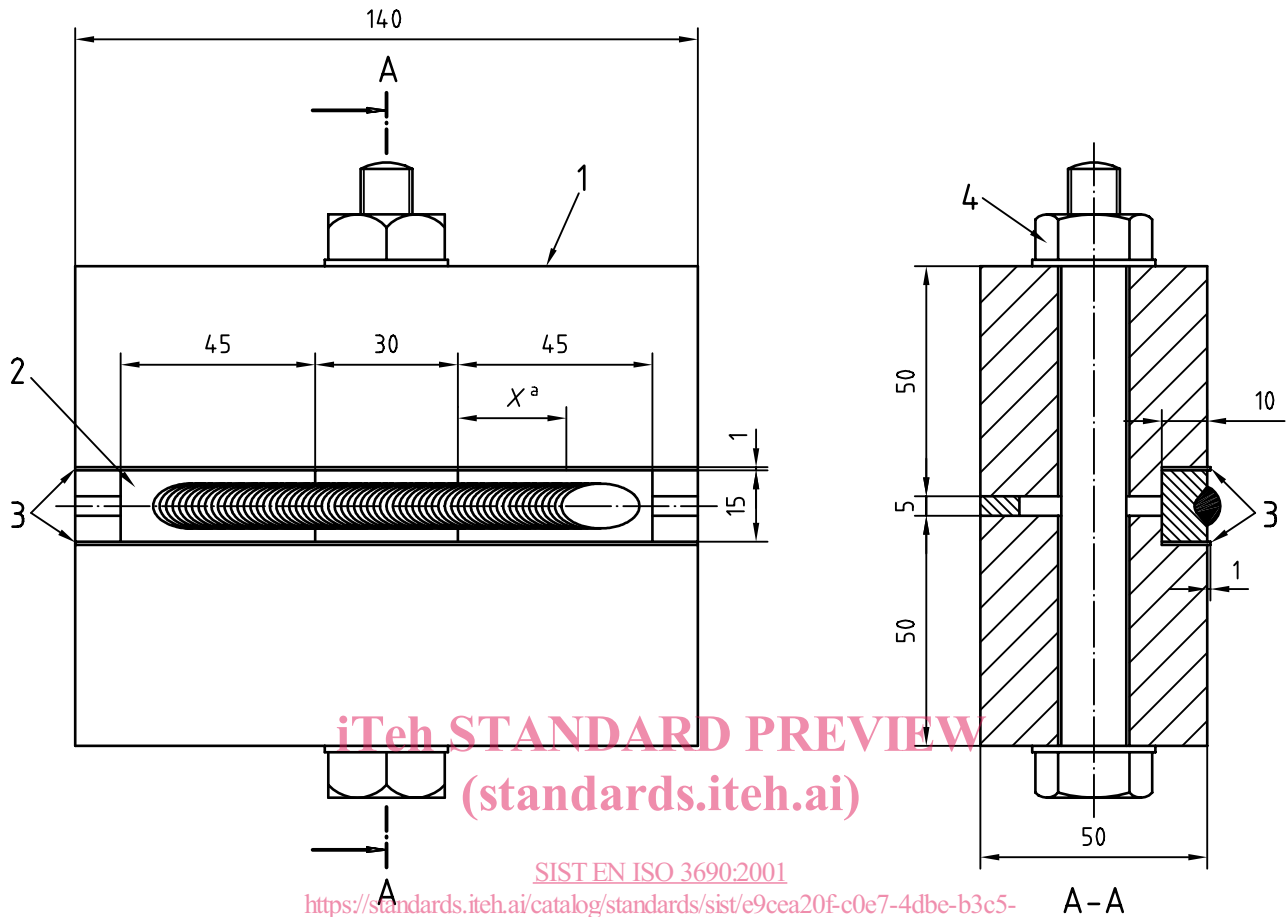
**Key**

- 1 Copper block
- 2 Test piece assembly
- 3 Copper foil
- 4 M12 bolt

NOTE Water cooling channels may be used.

^a Dimension $X \leq 25$ mm.

Figure 1 — Welding fixture and test piece assembly for weld deposits made with heat inputs up to 2 kJ/mm