



Standard Test Method for Using a Horizontal Pull Slipmeter (HPS)¹

This standard is issued under the fixed designation F 609; the number immediately following the designation indicates the year of original adoption or, in the case of revision, the year of last revision. A number in parentheses indicates the year of last reappraisal. A superscript epsilon (ϵ) indicates an editorial change since the last revision or reappraisal.

^{ε1} NOTE—Per Committee F13 Bylaws, editorially replaced term definitions with reference to Terminology F 1646 in January 2004.

1. Scope

1.1 This test method covers measurement of the static slip resistance of footwear sole, heel, or related materials on walkway surfaces in the laboratory and in the field.

1.2 The values stated in inch-pound units are to be regarded as the standard. The values given in parentheses are for information only.

1.3 *This standard does not purport to address all of the safety concerns, if any, associated with its use. It is the responsibility of the user of this standard to establish appropriate safety and health practices and determine the applicability of regulatory limitations prior to use.*

2. Referenced Documents

2.1 *ASTM Standards:*

F 1646 Terminology Relating to Safety and Traction for Footwear²

3. Terminology

3.1 See Terminology F 1646 for the following terms used in this test method:

3.1.1 Static slip resistance

4. Significance and Use

4.1 The Horizontal Pull Slipmeter³ is a laboratory and field instrument designed to provide information about the slip-resistant characteristics of footwear sole, heel, and related materials under dry conditions. However, the slip resistance of shoe sole and heel materials can be affected by factors other than the reaction of these materials with walkway surfaces, for

example, foreign materials on either the mating surfaces or the general maintenance of the surfaces. Consequently, unless all factors are taken into proper consideration, acceptable results from the measurements of slip resistance will not necessarily assure resistance to slipping.

5. Apparatus⁴

5.1 *Horizontal Pull Slipmeter*—See Fig. 1.

5.2 *Walkway Surface Panel*,⁵ not less than 9 by 9 in. (229 by 229 mm) square.

6. Reagents and Materials

6.1 *Ammonium Hydroxide Solution*, 3 %.

6.2 *Abrasive Paper*,⁶ Nos. 60 and 400 grit.

7. Test Specimens

7.1 The test specimens shall be 0.5 in. (12.7 mm) in diameter.

7.2 Three specimens are required for performance of the test.

7.3 In the case of test specimens that are to be cut from molded slab stock as supplied from the manufacturer for specification testing to be cut into shoe soles or heels, take nine specimens in three sets of three specimens each. Space the specimen locations as nearly equidistant from one another as possible in order to provide representative sampling throughout the sheet. (No specimen should be taken at a position less than 1.0 in. (25.4 mm) from any of the four edges of the sheet.) The purpose of this is to assure uniform thickness and state of cure among the specimens.

7.4 For routine testing of sheet materials intended to conform to previously approved specification sampling (see 7.3) of like material, the supplier and user of the material may agree mutually to use a simplified sampling procedure yielding three

¹ This test method is under the jurisdiction of ASTM Committee F13 on Safety and Traction for Footwear and is the direct responsibility of Subcommittee F13.10 on Traction.

Current edition approved Feb. 10, 1996. Published April 1996. Originally published as F 609 – 79. Last previous edition F 609 – 79 (1989)^{ε1}.

² For referenced ASTM standards, visit the ASTM website, www.astm.org, or contact ASTM Customer Service at service@astm.org. For *Annual Book of ASTM Standards* volume information, refer to the standard's Document Summary page on the ASTM website.

³ The Horizontal Pull Slipmeter was developed by C. H. Irvine of Liberty Mutual Insurance Co., Hopkinton, MA. The instrument is described in "A New Slipmeter for Evaluating Walkway Slipperiness," *Materials Research and Standards*, Vol 18, No. 12, December 1967, pp. 535–541.

⁴ Available from Whitley Industries, Inc., 939 C East St., Tewksbury, MA 01876. Phone: (508) 640-1177. Plans for the instrument may be obtained at a nominal cost from ASTM, 100 Barr Harbor Drive, West Conshohocken, PA 19428-2959. Request Adjunct No. 12-606090-47.

⁵ Walkway surfaces for testing may be any suitable tiles or floor panels selected by the laboratory or user.

⁶ Available from 3M Corp., St. Paul, MN 55100, and other abrasive paper manufacturers.

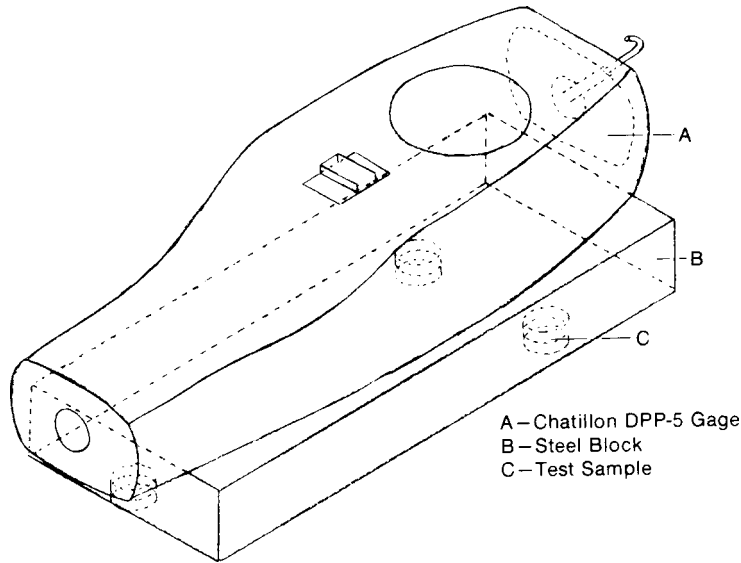

NOTE 1—Total weight of slipmeter less power unit is 2700 ± 34 g. Speed of power unit is 3.5 ± 0.5 in./min.

FIG. 1 Horizontal Pull Slipmeter

test specimens. A diagonal pattern is suggested, such as location A-1, B-2, and C-3 in the specimen location diagram (see Fig. 2).

7.5 When it is desired to test sole material taken from a finished shoe, take one specimen $\frac{1}{2}$ in. (12.7 mm) from each side of the widest part of the shoe sole (commonly called the “ball” area) and one specimen from the center of the toe area, a distance of $\frac{1}{2}$ in. (12.7 mm) from the tip of the shoe sole, for a total of three specimens.

7.6 For the sampling of a heel on a shoe, take three specimens in a pattern approximating an equilateral triangle with one apex in the rearward or smaller portion of the heel. No specimen should be taken less than $\frac{1}{4}$ in. (6.35 mm) from a heel edge.

7.7 It is recognized that in some shoe styles the heel area is insufficient to provide three specimens as recommended in 7.6.

In such cases, use one specimen each from the center of the walking surface of the heels on three separate shoes to provide the three specimens needed.

8. Calibration

8.1 Place the switch button, which is located just below gage, in the center position.

8.2 Grasp the slipmeter and hold in vertical position.

8.3 Set the gage on zero by moving the rim on the gage.

8.4 Use a separate hook to suspend the slipmeter by the hook located on one end of the slipmeter. The slipmeter should hang freely.

8.5 The needle on the dial of the gage should be within calibration range on the dial. (This reading is equivalent to the total weight, less the power unit, of the slipmeter if the dial indicated pounds rather than “slip index.”)

SAMPLE SET A	SAMPLE SET B	SAMPLE SET C
A-1	B-1	C-1
A-2	B-2	C-2
A-3	B-3	C-3

FIG. 2 Sampling Locations for Routine Testing of Sheet Materials