



**SLOVENSKI STANDARD**  
**SIST EN 14043:2005+A1:2009**  
**01-junij-2009**

---

**Visoke nadzemne naprave za gasilske enote - Avtomatske vrtljive gasilske avtolestve - Zahteve za varnost in obnašanje v uporabi in preskusne metode**

High rise aerial appliances for fire service use - Turntable ladders with combined movements - Safety and performance requirements and test methods

Hubrettungsfahrzeuge für die Feuerwehr - Drehleitern mit kombinierten Bewegungen (Automatik-Drehleitern) - Sicherheits- und Leistungsanforderungen sowie Prüfverfahren

Moyens élévateurs aériens pour la lutte contre l'incendie - Echelles pivotantes à mouvements combinés - Prescriptions de sécurité et de performances et méthodes d'essais

<https://standards.iteh.ai/catalog/standards/sist/ab0e095f-3cc7-4747-92c8-e6ef55b73d96/sist-en-14043-2005a1-2009>

**Ta slovenski standard je istoveten z: EN 14043:2005+A1:2009**

---

**ICS:**

13.220.10	Gašenje požara	Fire-fighting
97.145	Lestve	Ladders

**SIST EN 14043:2005+A1:2009**                      **en,fr,de**

**iTeh STANDARD PREVIEW**  
**(standards.iteh.ai)**

SIST EN 14043:2005+A1:2009

<https://standards.iteh.ai/catalog/standards/sist/ab0e095f-3cc7-4747-92c8-e6ef55b73d96/sist-en-14043-2005a1-2009>

EUROPEAN STANDARD  
NORME EUROPÉENNE  
EUROPÄISCHE NORM

**EN 14043:2005+A1**

March 2009

ICS 13.220.10

Supersedes EN 14043:2005

English Version

## High rise aerial appliances for fire service use - Turntable ladders with combined movements - Safety and performance requirements and test methods

Moyens élévateurs aériens pour la lutte contre l'incendie -  
Echelles pivotantes à mouvements combinés -  
Prescriptions de sécurité et de performances et méthodes  
d'essais

Hubrettungsfahrzeuge für die Feuerwehr - Drehleitern mit  
kombinierten Bewegungen (Automatik-Drehleitern) -  
Sicherheits- und Leistungsanforderungen sowie  
Prüfverfahren

This European Standard was approved by CEN on 1 August 2005 and includes Corrigendum 1 issued by CEN on 6 December 2006 and Amendment 1 approved by CEN on 11 January 2009.

CEN members are bound to comply with the CEN/CENELEC Internal Regulations which stipulate the conditions for giving this European Standard the status of a national standard without any alteration. Up-to-date lists and bibliographical references concerning such national standards may be obtained on application to the CEN Management Centre or to any CEN member.

This European Standard exists in three official versions (English, French, German). A version in any other language made by translation under the responsibility of a CEN member into its own language and notified to the CEN Management Centre has the same status as the official versions.



CEN members are the national standards bodies of Austria, Belgium, Bulgaria, Cyprus, Czech Republic, Denmark, Estonia, Finland, France, Germany, Greece, Hungary, Iceland, Ireland, Italy, Latvia, Lithuania, Luxembourg, Malta, Netherlands, Norway, Poland, Portugal, Romania, Slovakia, Slovenia, Spain, Sweden, Switzerland and United Kingdom.



EUROPEAN COMMITTEE FOR STANDARDIZATION  
COMITÉ EUROPÉEN DE NORMALISATION  
EUROPÄISCHES KOMITEE FÜR NORMUNG

Management Centre: Avenue Marnix 17, B-1000 Brussels

## Contents

	Page
Foreword.....	3
Introduction .....	4
1 Scope .....	5
2 Normative references .....	5
3 Terms and definitions, symbols and abbreviated terms .....	6
4 List of significant hazards.....	12
5 Requirements .....	22
5.1 Safety requirements and/or measures .....	22
5.1.1 General.....	22
5.1.2 Requirements in respect of stability.....	22
5.1.3 Fatigue stress analysis .....	32
5.1.4 Verifications relating to the strength of the turntable ladder.....	33
5.1.5 Requirements regarding fitness.....	34
5.1.6 Requirements relating to function .....	35
5.1.7 Requirements relating to noise .....	64
5.2 Performance requirements .....	64
5.2.1 Operational requirements .....	64
5.2.2 Requirements demanded by national regulations .....	65
5.2.3 Overall maximum dimensions .....	65
5.2.4 Radio disturbances.....	66
6 Designation.....	67
7 Information for use .....	67
7.1 General.....	67
7.2 Instruction handbook .....	67
7.2.1 General.....	67
7.2.2 Operating instruction.....	68
7.2.3 Transport, handling and storage information.....	69
7.2.4 Information on commissioning .....	69
7.2.5 Machine details .....	69
7.2.6 Maximum allowable loads in the cage and/or on the ladder set.....	69
7.2.7 Maintenance information for use by trained personnel.....	70
7.2.8 Special working methods or conditions.....	70
7.3 Marking .....	70
7.4 Periodical examinations and tests .....	72
Annex A (informative) Example of table reporting the stability tests .....	74
Annex B (normative) Operating time.....	75
Annex C (informative) List of national regulations applicable to turntable ladders .....	76
Annex D (informative) Verification and periodic inspections .....	77
Annex ZA (informative) Relationship between this European Standard and the Essential Requirements of EU Directive 98/37/EC .....	80
Annex ZB (informative)  Relationship between this European Standard and the Essential Requirements of EU Directive 2006/42/EC  .....	81
Bibliography.....	82

## Foreword

This document (EN 14043:2005+A1:2009) has been prepared by Technical Committee CEN/TC 192 “Fire service equipment”, the secretariat of which is held by BSI.

This European Standard shall be given the status of a national standard, either by publication of an identical text or by endorsement, at the latest by September 2009, and conflicting national standards shall be withdrawn at the latest by December 2009.

This document includes Amendment 1, approved by CEN on 2009-01-11 and Corrigendum 1, issued by CEN on 2006-12-06.

This document supersedes EN 14043:2005.

The start and finish of text introduced or altered by amendment is indicated in the text by tags  $\boxed{A_1}$   $\boxed{A_1}$ .

The modifications of the related CEN Corrigendum have been implemented at the appropriate places in the text and are indicated by the tags  $\boxed{AC}$   $\boxed{AC}$ .

This European Standard has been prepared under a mandate given to CEN by the European Commission and the European Free Trade Association, and supports essential requirements of EU Directive(s).

$\boxed{A_1}$  For relationship with EU Directive(s), see Informative Annexes ZA and ZB, which are integral parts of this document.  $\boxed{A_1}$

NOTE This European Standard is intended to be used in conjunction with EN 1846-1, EN 1846-2 and EN 1846-3.

According to the CEN/CENELEC Internal Regulations, the national standards organizations of the following countries are bound to implement this European Standard: Austria, Belgium, Bulgaria, Cyprus, Czech Republic, Denmark, Estonia, Finland, France, Germany, Greece, Hungary, Iceland, Ireland, Italy, Latvia, Lithuania, Luxembourg, Malta, Netherlands, Norway, Poland, Portugal, Romania, Slovakia, Slovenia, Spain, Sweden, Switzerland and United Kingdom.

**EN 14043:2005+A1:2009 (E)****Introduction**

This European Standard is a type C standard as stated in EN ISO 12100.

The machinery concerned and the extent to which hazards, hazardous situations and events are covered are indicated in the scope of this European Standard.

When provisions of this type C standard are different from those which are stated in type A or B standards, the provisions of this type C standard take precedence over the provisions of the other standards, for machines that have been designed and built according to the provisions of this type C standard.

**iTeh STANDARD PREVIEW  
(standards.iteh.ai)**

SIST EN 14043:2005+A1:2009

<https://standards.iteh.ai/catalog/standards/sist/ab0e095f-3cc7-4747-92c8-e6ef55b73d96/sist-en-14043-2005a1-2009>

## 1 Scope

**1.1** This European Standard specifies the safety and performance requirements and test methods applicable to turntable ladders with combined movements of classes 18, 24 and 30, as defined in 3.13, under the control of fire-fighters and intended for fire fighting and rescuing people.

Turntable ladder vehicles comprise a chassis, bodywork and a powered extending structure unit in the form of a ladder with or without a cage.

Turntable ladder vehicles covered by this European Standard have a self-propelled chassis, the motor of which supplies power required for the operation of the ladder and permits all of the operational movements to be made simultaneously, with no restriction on the angle of the training movement.

**1.2** This European Standard deals with the technical safety requirements to minimise the hazards listed in Clause 4 which can arise during the commissioning, the operational use, the routine checking and maintenance of turntable ladders when carried out in accordance with the specifications given by the manufacturer or his authorised representative.

It also deals with performance requirements.

**1.3** This European Standard deals with the use of turntable ladder vehicles within a temperature range from - 15 °C to + 35 °C and with a wind velocity on the ladder set  $\leq 12,5$  m/s. Additional measures can be necessary for use outside this range (to be negotiated between the manufacturer and the user).

NOTE Special designs for use under special climatic conditions are arranged between the manufacturer and the purchaser.

<https://standards.iteh.ai/catalog/standards/sist/ab0e095f-3cc7-4747-92c8-e6ef55b73d96/sist-en-14043-2005a1-2009>

**1.4** This European Standard does not deal with the hazards of the standard automotive chassis or due to use as a road vehicle.

**1.5** This European Standard is not applicable to turntable ladder vehicles with combined movements which are manufactured before the date of publication of this European Standard by CEN.

## 2 Normative references

The following referenced documents are indispensable for the application of this European Standard. For dated references, only the edition cited applies. For undated references, the latest edition of the referenced document (including any amendments) applies.

EN 418:1992, *Safety of machinery — Emergency stop equipment, functional aspects — Principles for design*

EN 457, *Safety of machinery — Auditory danger signals — General requirements, design and testing (ISO 7731:1986, modified)*

EN 954-1:1996, *Safety of machinery — Safety related parts of control systems — Part 1: General principles for design*

EN 982, *Safety of machinery — Safety requirements for fluid power systems and their components — Hydraulics*

EN 1050:1996, *Safety of machinery — Risk assessment*

EN 1846-1:1998, *Firefighting and rescue service vehicles — Part 1: Nomenclature and designation*

**EN 14043:2005+A1:2009 (E)**

EN 1846-2:2001, *Firefighting and rescue service vehicles — Part 2: Common requirements — Safety and performance*

EN 1846-3:2002, *Firefighting and rescue service vehicles — Part 3: Permanently installed equipment — Safety and performance*

EN 60204-1:1997, *Safety of machinery — Electrical equipment of machines — Part 1: General requirements (IEC 60204-1:1997, modified)*

EN 60529, *Degrees of protection provided by enclosures (IP code) (IEC 60529:1989)*

EN 61310-1, *Safety of machinery — Indication, marking and actuation — Part 1: Requirements for visual, auditory and tactile signals (IEC 61310-1:1995)*

EN ISO 11688-1, *Acoustics — Recommended practice for the design of low-noise machinery and equipment — Part 1: Planning (ISO/TR 11688-1:1995)*

EN ISO 12100-1:2003, *Safety of machinery — Basic concepts, general principles for design — Part 1: Basic terminology, methodology (ISO 12100-1:2003)*

EN ISO 12100-2:2003, *Safety of machinery — Basic concepts, general principles for design — Part 2: Technical principles (ISO 12100-2:2003)*

ISO 4302, *Cranes — Wind load assessment*

## iTeh STANDARD PREVIEW

### 3 Terms and definitions, symbols and abbreviated terms

(standards.iteh.ai)

For the purposes of this European Standard, the terms and definitions given in EN ISO 12100-1:2003, EN 1846-1:1998, EN 1846-2:2001 and the following apply.

<https://standards.iteh.ai/catalog/standards/sist/ab0e095f3cc7-4747-92c8-e6e55b73d96/sist-en-14043-2005a1-2009>

#### 3.1

##### **turntable ladder with combined movements**

machine with an extending structure in the form of a ladder set mounted on a self-propelled chassis. The chassis engine supplies the power required for operation. For ladders with combined movements, at least the elevation/depression, extending/housing and the training right/left, are simultaneously possible under the continuous control of the operator. There is no restriction on the angle of the training movement

#### 3.2

##### **turntable ladder equipment**

entire assembly of the mobile components mounted on the chassis which can carry at its upper extent, fixed or removable rescue equipment

NOTE The jacking system is part of the turntable ladder equipment.

#### 3.3

##### **ladder set**

part of turntable ladder comprising several ladder sections which are connected together so as to extend telescopically

#### 3.4

##### **extended ladder set length**

*L*

distance, expressed in metres, between the extreme points of the extended ladder

#### 3.5

##### **rescue cage**

fixed or removable complementary device principally used for firefighting, rescuing people and other operational services



**3.6****angle of elevation** $\alpha$ 

angle, expressed in degrees, between the longitudinal axis of the last (downmost) ladder section and the horizontal

**3.7****camber angle** $\beta$ 

angle, expressed in degrees, in the transverse direction to the longitudinal axis of the vehicle between the horizontal and the ground surface

**3.8****gradient angle** $\gamma$ 

angle, expressed in degrees, in the longitudinal axis of the vehicle between the horizontal and the ground surface

**3.9****training angle** $\theta$ 

angle, expressed in degrees, determined clockwise between the longitudinal axis of the vehicle and the longitudinal axis of the last ladder section projection

NOTE The zero degrees position corresponds to the longitudinal axis of the vehicle facing towards the driver's cab.

**3.10****rescue height** $h$ 

vertical height, expressed in metres, from the horizontal ground surface to the base of the rescue cage without loading. The height of the topmost ladder round is taken as the rescue height in the case of turntable ladders without cage

**iTeh STANDARD PREVIEW**  
(standards.iteh.ai)

[SIST EN 14043:2005+A1:2009](https://standards.iteh.ai/catalog/standards/sist/ab0e095f-3cc7-4747-92c8-e6e55b73d96/sist-en-14043-2005a1-2009)

<https://standards.iteh.ai/catalog/standards/sist/ab0e095f-3cc7-4747-92c8-e6e55b73d96/sist-en-14043-2005a1-2009>

**3.11****nominal rescue height** $h_N$ 

specified height, expressed in metres, at nominal reach

**3.12****maximum rescue height** $h_m$ 

height, expressed in metres, at the maximum angle of elevation and the maximum extension distance

**3.13****ladder's class**

identification of a turntable ladder as class which corresponds to the value equal or immediately less than the maximum rescue height, expressed in metres

**3.14****horizontal projection** $l$ 

distance, expressed in metres, from the outer edge of the vehicle to the perpendicular dropped from the outer edge of the base of the rescue cage or the working platform or the projection from the outer edge of the vehicle to perpendicular from the topmost round

NOTE 1 The measurement is taken at right angles to the longitudinal axis of the vehicle on horizontal terrain without loading.

NOTE 2 If the jacks extend beyond the maximum width of the vehicle, the distance is measured from the outer edge of the most extended jack.

**EN 14043:2005+A1:2009 (E)****3.15****nominal rescue projection** $l_N$ 

specified horizontal projection at nominal rescue height; measured in accordance with 3.11, expressed in metres

**3.16****nominal reach** $h-l$ 

coordinates derived from rescue height and horizontal projection

NOTE Values for the nominal reaches may be specified in the regulations in force in each country (see 5.2.2).

**3.17****nominal load** $P_N$ 

specified load, expressed in Newtons, with which a rescue cage or the tip of the turntable ladder may be loaded vertically within the corresponding range of free-standing use

NOTE 1 Permanently fixed equipment is not included in the nominal load.

NOTE 2 This nominal load may be exceeded to a certain extent (see 3.19 and 3.20).

**3.18****test loads** $P_P$ 

specified loads applied in tests for stability, overload, and proper functioning etc. of the turntable ladder

**3.19****supplementary load** $P_Z$ 

load permitted by the manufacturer in addition to the nominal load, e.g. loose equipment

**3.20****maximum working load** $P_L$ 

greatest load with which the turntable ladder may be loaded

NOTE  $P_L = P_N + P_Z$

**3.21****residual force** $F_R$ 

force (at any ladder position and loading within the range of use) which is transferred to the bearing surface on the unloaded side of the vehicle during operation of the turntable ladder (see Figure 4)

NOTE For stability calculation front axle(s) is (are) not considered to be a bearing surface(s) in this instance.

**3.22****range of use**

space within which the turntable ladder may be operated without endangering stability

**3.22.1****range of free-standing use**

space in which the movement at the maximum working load  $P_L$  permitted for this range does not endanger the stability of the turntable ladder, the head of the ladder set being unsupported

**3.22.2****range of supported use**

space of use in which the movement without loading does not endanger stability of the turntable ladder. Within this space, the head of the turntable ladder set is supported, at the objective, before applying the load

### 3.23 boundary (see Figure 1)

#### 3.23.1

##### free standing boundary

boundary in the range of free-standing use within which movement is permitted with the load  $P_L$  permitted for this range

#### 3.23.2

##### supported boundary

boundary in the range of supported use within which movement in this area is permitted

#### 3.23.3

##### special boundary of use

boundary corresponding to a range of use, with or without cage, without load

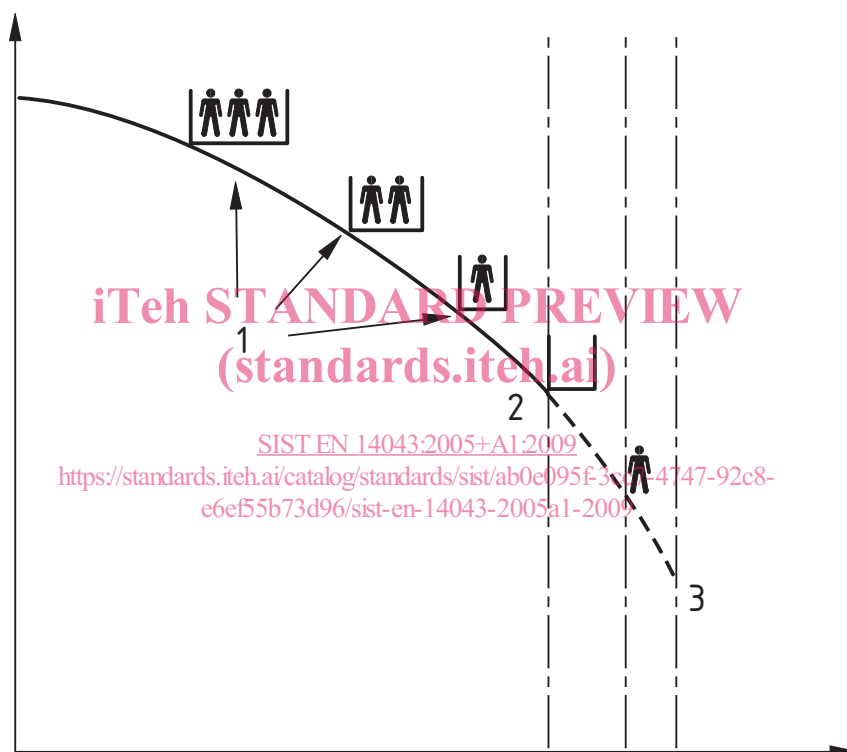

#### Key

- 1 Free standing boundary (3.23.1)
- 2 Special boundary of use, load = 0 + turntable ladder equipment (3.23.3)
- 3 Supported boundary of use, load + cage = 0 (3.23.2)

Figure 1 — Example of boundary

## EN 14043:2005+A1:2009 (E)

### 3.24 jacking width

$b$

distance at right angles between two imaginary parallel lines to be drawn on either side of the central axis of the vehicle at the outer edges of the furthest extended and lowered jacks (see Figure 2)

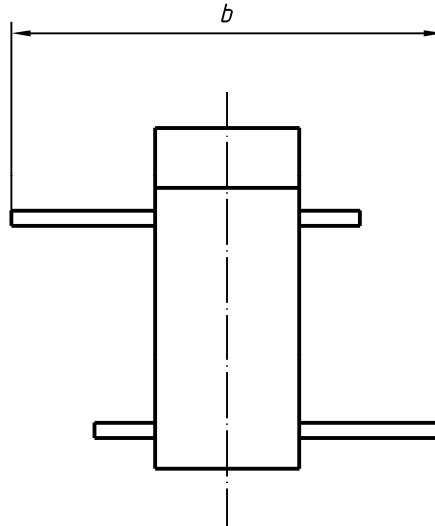

NOTE It is assumed, for this measurement, that the vehicle is standing on a horizontal surface.

(standards.iteh.ai)

Figure 2 — Jacking width

SIST EN 14043:2005+A1:2009

<https://standards.iteh.ai/catalog/standards/sist/ab0e095f-3cc7-4747-92c8-e6e55b73d96/sist-en-14043-2005a1-2009>

### 3.25 operating time

$t_R$

time required in order to reach, from the travel position, the maximum rescue height (at 90° to the longitudinal axis of the chassis)

NOTE If appropriate the operating time ( $t_R$ ) includes the time for attaching the cage and making it ready for use with the ladder stabilized at maximum jacking width by the vehicle.

### 3.26 stability test – static

verification test of a turntable ladder's ability to resist tipping or rolling over with the ladder set not being moved under load

### 3.27 stability test – dynamic

verification test of a turntable ladder's ability to resist tipping or rolling over with the ladder set being permitted to move under load

### 3.28 static overload test

static test of the turntable ladder for permanent deformation

NOTE The static overload test is not a stability test.

### 3.29 test of fitness for purpose

test to confirm the correct functioning of all the functions of a turntable ladder and its special equipment

**3.30****forces and loads for calculations**

NOTE 1 Forces are expressed in Newtons and are measured in the direction in which they act.

NOTE 2 Loads are forces resulting from the mass of the components and are expressed in Newtons. Their direction is the direction of the gravity.

**3.30.1****static loads**

forces resulting from the masses, expressed in kilograms, which are not moved during operation of the turntable ladder

**3.30.2****dynamic loads**

forces resulting from masses, expressed in kilograms, which are moved during operation of the turntable ladder, including equipment moved with them, e.g. rescue cage

**3.30.3****load per person**

load resulting from an assumed mass of 90 kg per person and forming part of the total load indicated as the number of persons

**3.30.4****wind loads**

forces, expressed in Newtons, acting on the turntable ladder equipment, persons

**3.30.5****diverse forces**

forces, expressed in Newtons, exerted by persons on the rescue cage or the turntable ladder equipment and forces, expressed in Newtons resulting from any particular action during ladder operation

NOTE Manual forces in the rescue cage and reaction forces from the water jets are examples of diverse forces.

**3.30.6****dead weight load**

$F_G$

forces, expressed in Newtons, engendered by the vehicle without ladder set (see Figure 4 and Table 2)

**3.30.7****unloaded ladder load**

$F_E$

forces, expressed in Newtons, engendered by unloaded ladder set (see Figure 4 and Table 2)

**3.30.8****inertial forces of the extended ladder**

$F_n$

forces, expressed in Newtons, resulting from the inertia of the extended ladder

**3.31****useful area of the rescue cage**

$A$

area of the floor minus the area occupied by the fixed equipment located completely or partially within the rescue cage or its perpendicular projection with the exception of the handrail and dead man's pedal if this is located on the floor

**3.32****plumbing (rounds)**

movement which allows the ladder rounds to be maintained horizontally

**EN 14043:2005+A1:2009 (E)****3.33****levelling (cage floor)**

movement which allows the cage floor to be maintained at right angles to the direction of gravity whatever may be its position on the ladder set

**3.34****transport position (ladder with cage)**

position in which the jacks are housed, the ladder set being fully housed and resting on its gantry and the power supply to the ladder set being isolated and the rescue cage unfolded

NOTE This position allows the vehicle to be moved a short distance.

**3.35****travel position**

same conditions as the transport position and the following additional condition: the rescue cage is housed or stowed

**3.36****ladder set sections**

ladder set comprises a first section (upper), a last section (lower) fixed to the cradle, and the intermediate sections (second section, third section, etc) counted from the first section towards the last (see Figure 3)

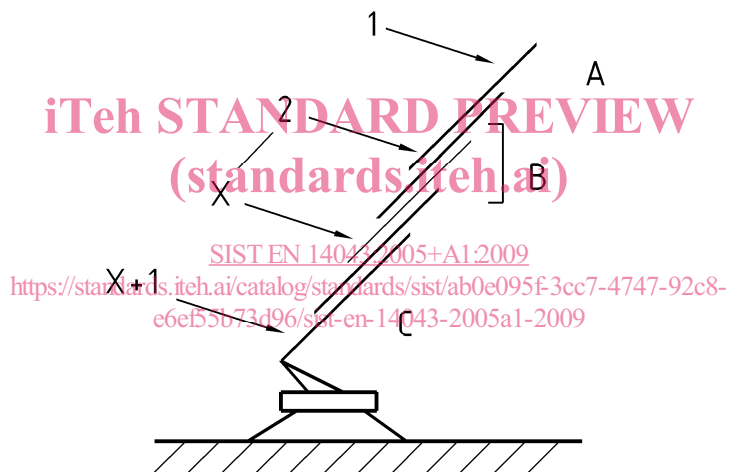
**Key**

- A First section
- B Intermediate sections
- C Last section

**Figure 3 — Designation of ladder set sections**

**4 List of significant hazards**

This clause contains all the significant hazards, hazardous situations and events, as far as they are dealt with in this European Standard, identified by risk assessment as significant for this type of machinery and which require action to eliminate or reduce the risk.

Table 1 — List of significant hazards

Clause/ subclause reference in EN 1050:1996	Hazard	Assembly	Process/Function/ cause	Clause/subclause in this European Standard or in others standards
<b>1</b>	<b>Mechanical hazards</b>			
<b>1.1</b>	<b>Crushing hazard</b>	Jacks	Moving the jacks	<ul style="list-style-type: none"> <li>• 5.1.6.2.11</li> <li>• 5.1.6.2.15</li> <li>• 5.1.6.5.2</li> <li>• 7</li> </ul>
			Pressure of the jacks on the ground	<ul style="list-style-type: none"> <li>• 5.1.6.5.2</li> <li>• 5.1.6.2.12</li> <li>• 5.1.6.2.13</li> <li>• 5.1.6.2.14</li> <li>• 7</li> </ul>
			Uncontrolled movement (lifting on the base plate)	<ul style="list-style-type: none"> <li>• 5.1.6.2.14</li> </ul>
		Suspensions locking device	Re-establishing ground contact with the tyres during return to travel position	<ul style="list-style-type: none"> <li>• 5.1.6.2.15</li> </ul>
			Defect in the suspension locking device on activation	<ul style="list-style-type: none"> <li>• 5.1.6.2.1</li> <li>• 7</li> </ul>
		Cradle/turret	Crushing by the training drive mechanism	<ul style="list-style-type: none"> <li>• 5.1.6.7.1</li> </ul>
			Crushing by the turret in motion	<ul style="list-style-type: none"> <li>• 5.1.6.7.1</li> <li>• 5.1.6.7.2</li> </ul>
			Crushing by the cradle in motion	<ul style="list-style-type: none"> <li>• 5.1.6.7.1</li> </ul>
		Ladder set	Crushing between the rounds during extending and housing	<ul style="list-style-type: none"> <li>• 5.1.6.5.3</li> <li>• 5.1.6.8.1</li> <li>• 7</li> </ul>
		Rescue cage	Crushing by mobile parts during levelling correction	<ul style="list-style-type: none"> <li>• 5.1.6.4.8</li> </ul>