



Designation: C697 – 04

Standard Test Methods for Chemical, Mass Spectrometric, and Spectrochemical Analysis of Nuclear-Grade Plutonium Dioxide Powders and Pellets¹

This standard is issued under the fixed designation C697; the number immediately following the designation indicates the year of original adoption or, in the case of revision, the year of last revision. A number in parentheses indicates the year of last reapproval. A superscript epsilon (ϵ) indicates an editorial change since the last revision or reapproval.

1. Scope

1.1 These test methods cover procedures for the chemical, mass spectrometric, and spectrochemical analysis of nuclear-grade plutonium dioxide powders and pellets to determine compliance with specifications.

1.2 The analytical procedures appear in the following order:

	Sections
Plutonium Sample Handling	8 to 10
Plutonium by Controlled-Potential Coulometry	2
Plutonium by Ceric Sulfate Titration	3
Plutonium by Amperometric Titration with Iron(II)	2
Plutonium by Diode Array Spectrophotometry	3
Nitrogen by Distillation Spectrophotometry Using Nessler Reagent	11 to 18
Carbon (Total) by Direct Combustion–Thermal Conductivity	19 to 30
Total Chlorine and Fluorine by Pyrohydrolysis	31 to 38
Sulfur by Distillation Spectrophotometry	39 to 47
Plutonium Isotopic Analysis by Mass Spectrometry	4
Rare Earth Elements by Spectroscopy	48 to 55
Trace Elements by Carrier–Distillation Spectroscopy	56 to 63
Impurities by ICP-AES	
Impurity Elements by Spark-Source Mass Spectrography	64 to 70
Moisture by the Coulometric Electrolytic Moisture Analyzer	71 to 78
Total Gas in Reactor-Grade Plutonium Dioxide Pellets	79 to 86
Plutonium-238 Isotopic Abundance by Alpha Spectrometry	3
Americium-241 in Plutonium by Gamma-Ray Spectrometry	2
Rare Earths By Copper Spark-Spectroscopy	87 to 96
Plutonium Isotopic Analysis by Mass Spectrometry	97 to 105
Oxygen-To-Metal Atom Ratio by Gravimetry	106 to 114

1.3 *This standard does not purport to address all of the safety concerns, if any, associated with its use. It is the responsibility of the user of this standard to establish appropriate safety and health practices and determine the applicability of regulatory limitations prior to use.* For specific precautionary statements, see Sections 6, 15, 24, 111, and 52.9 and 101.5.1 .

¹ These test methods are under the jurisdiction of ASTM Committee C26 on Nuclear Fuel Cycle and are the direct responsibility of Subcommittee C26.05 on Methods of Test.

Current edition approved Jan. 1, 2004. Published February 2004. Originally approved in 1972. Last previous edition approved in 1998 as C697 – 98. DOI: 10.1520/C0697-04.

² Discontinued as of November 15, 1992.

³ Discontinued as of January 1, 2004.

⁴ Discontinued as of May 30, 1980.

2. Referenced Documents

2.1 ASTM Standards:⁵

C757 Specification for Nuclear-Grade Plutonium Dioxide Powder, Sinterable

C852 Guide for Design Criteria for Plutonium Gloveboxes

C1009 Guide for Establishing a Quality Assurance Program for Analytical Chemistry Laboratories Within the Nuclear Industry

C1068 Guide for Qualification of Measurement Methods by a Laboratory Within the Nuclear Industry

C1108 Test Method for Plutonium by Controlled-Potential Coulometry

C1128 Guide for Preparation of Working Reference Materials for Use in Analysis of Nuclear Fuel Cycle Materials

C1156 Guide for Establishing Calibration for a Measurement Method Used to Analyze Nuclear Fuel Cycle Materials

C1165 Test Method for Determining Plutonium by Controlled-Potential Coulometry in H₂SO₄ at a Platinum Working Electrode

C1168 Practice for Preparation and Dissolution of Plutonium Materials for Analysis

C1206 Test Method for Plutonium by Iron (II)/Chromium (VI) Amperometric Titration

C1210 Guide for Establishing a Measurement System Quality Control Program for Analytical Chemistry Laboratories Within the Nuclear Industry

C1235 Test Method for Plutonium by Titanium(III)/Cerium(IV) Titration⁶

C1268 Test Method for Quantitative Determination of Americium 241 in Plutonium by Gamma-Ray Spectrometry

C1297 Guide for Qualification of Laboratory Analysts for the Analysis of Nuclear Fuel Cycle Materials

⁵ For referenced ASTM standards, visit the ASTM website, www.astm.org, or contact ASTM Customer Service at service@astm.org. For *Annual Book of ASTM Standards* volume information, refer to the standard's Document Summary page on the ASTM website.

⁶ Withdrawn. The last approved version of this historical standard is referenced on www.astm.org.

- C1307** Test Method for Plutonium Assay by Plutonium (III) Diode Array Spectrophotometry
- C1415** Test Method for ²³⁸Pu Isotopic Abundance By Alpha Spectrometry
- C1432** Test Method for Determination of Impurities in Plutonium: Acid Dissolution, Ion Exchange Matrix Separation, and Inductively Coupled Plasma-Atomic Emission Spectroscopic (ICP/AES) Analysis
- D1193** Specification for Reagent Water
- E60** Practice for Analysis of Metals, Ores, and Related Materials by Molecular Absorption Spectrometry
- E115** Practice for Photographic Processing in Optical Emission Spectrographic Analysis⁶
- E116** Practice for Photographic Photometry in Spectrochemical Analysis⁶

3. Significance and Use

3.1 Plutonium dioxide is used in mixtures with uranium dioxide as a nuclear-reactor fuel. In order to be suitable for this purpose, the material must meet certain criteria for plutonium content, isotopic composition, and impurity content. These test methods are designed to show whether or not a given material meets the specifications for these items as described in Specification **C757**.

3.1.1 An assay is performed to determine whether the material has the minimum plutonium content specified on a dry weight basis.

3.1.2 Determination of the isotopic content of the plutonium in the plutonium dioxide powder is made to establish whether the effective fissile content is in compliance with the purchaser's specifications.

3.1.3 Impurity content is determined to ensure that the maximum concentration limit of certain impurity elements is not exceeded. Determination of impurities is also required for calculation of the equivalent boron content (EBC).

4. Committee C-26 Safeguards Statement⁷

4.1 The materials (plutonium dioxide powders and pellets) to which these test methods apply are subject to nuclear safeguards regulations governing their possession and use. The following analytical procedures in these test methods have been designated as technically acceptable for generating safeguards accountability measurement data: Plutonium by Controlled-Potential Coulometry; Plutonium by Ceric Sulfate Titration; Plutonium by Amperometric Titration with Iron (II); Plutonium by Diode Array Spectrometry Plutonium-238 Isotopic Abundance by Alpha Spectrometry; and Plutonium Isotopic Analysis by Mass Spectrometry.

4.2 When used in conjunction with appropriate Certified Reference Materials (CRMs), these procedures can demonstrate traceability to the national measurement base. However, adherence to these procedures does not automatically guarantee regulatory acceptance of the resulting safeguards measurements. It remains the sole responsibility of the user of these test

methods to assure that its application to safeguards has the approval of the proper regulatory authorities.

5. Reagents

5.1 *Purity of Reagents*—Reagent grade chemicals shall be used in all tests. Unless otherwise indicated, it is intended that all reagents shall conform to the specifications of the Committee on Analytical Reagents of the American Chemical Society, where such specifications are available.⁸ Other grades may be used, provided it is first ascertained that the reagent is of sufficiently high purity to permit its use without lessening the accuracy of the determination.

5.2 *Purity of Water*—Unless otherwise indicated, references to water shall be understood to mean reagent water conforming to Specification **D1193**.

6. Safety Precautions

6.1 Since plutonium bearing materials are radioactive and toxic, adequate laboratory facilities, gloved boxes, fume hoods, etc., along with safe techniques, must be used in handling samples containing these materials. A detailed discussion of all the precautions necessary is beyond the scope of these test methods; however, personnel who handle these materials should be familiar with such safe handling practices as are given in Guide 852**C852** and in Refs (1) through (3).⁹

7. Sampling and Dissolution

7.1 Criteria for sampling this material are given in Specification **C757**.

7.2 Samples can be dissolved using the appropriate dissolution technique described in Practice **C1168**.

PLUTONIUM SAMPLE HANDLING

8. Scope

8.1 This test method covers the conditions necessary to preserve the integrity of plutonium dioxide samples. Conditions listed here are directed toward the analytical chemist. However, they are just as applicable to any group handling the material.

9. Summary of Test Method

9.1 Plutonium dioxide is very hygroscopic. In a short time it can sorb sufficient water from an uncontrolled atmosphere to destroy the validity of the most accurate analytical methods. An atmosphere with a dew point of -23°C has been found adequate to prevent sorption of water, but care must be exercised to use equipment and sample containers known to be dry.

⁸ *Reagent Chemicals, American Chemical Society Specifications*, American Chemical Society, Washington, DC. For suggestions on the testing of reagents not listed by the American Chemical Society, see *Analar Standards for Laboratory Chemicals*, BDH Ltd., Poole, Dorset, U.K., and the *United States Pharmacopeia and National Formulary, U.S. Pharmacopeial Convention, Inc. (USPC)*, Rockville, MD.

⁹ The boldface numbers in parentheses refer to the list of references at the end of these test methods.

⁷ Based upon Committee C-26 Safeguards Matrix (**C1009**, **C1068**, **C1128**, **C1156**, **C1210**, **C1297**).

10. Sample Handling Conditions

10.1 All sampling and critical weighings are to be performed in an atmosphere with a dew point no greater than -23°C .

10.2 All sampling equipment, including bottles, is to be dried before use. Plastic bottles are not to be used since they cannot be adequately dried. Glass bottles and aluminum foil are to be dried at 110°C for at least 1 h and kept in a desiccator until used.

NOTE 1—It has been shown that plutonium dioxide will sorb water from apparently dry aluminum foil. The foil should be dried at 110°C before use.

10.3 Quantitative methods to correct for moisture absorption, such as drying, must be avoided. The sample will not be representative under these conditions. It is virtually impossible to get equal amounts of moisture in the sample and bulk of the material at the same time.

PLUTONIUM BY CONTROLLED-POTENTIAL COULOMETRY

(This test method was discontinued in 1992 and replaced by Test Method C1165.)

PLUTONIUM BY CONTROLLED-POTENTIAL COULOMETRY

(With appropriate sample preparation, controlled-potential coulometric measurement as described in Test Method C1108 may be used for plutonium determination.)

PLUTONIUM BY CERIC SULFATE TITRATION

(This test method was discontinued in 2003 and replaced by Test Method C1235.)

PLUTONIUM BY AMPEROMETRIC TITRATION WITH IRON (II)

(This test method was discontinued in 1992 and replaced by Test Method C1206.)

STANDARD TEST METHOD FOR PLUTONIUM ASSAY BY PLUTONIUM(III) DIODE ARRAY SPECTROPHOTOMETRY

(With appropriate sample preparation, the measurement described in Test Method C1307 may be used for plutonium determination.)

NITROGEN BY DISTILLATION SPECTROPHOTOMETRY USING NESSLER REAGENT

11. Scope

11.1 This test method covers the determination of 5 to 100 $\mu\text{g/g}$ of nitride nitrogen in 1-g samples of nuclear-grade plutonium dioxide.

12. Summary of Test Method

12.1 The sample is dissolved in hydrochloric acid by the sealed tube method or by phosphoric acid hydrofluoric acid solution, after which the solution is made basic with sodium hydroxide and nitrogen is separated as ammonia by steam distillation. Nessler reagent is added to the distillate to form the yellow ammonium complex and the absorbance of the solution is measured at approximately 430 nm (4,5).

13. Apparatus

13.1 *Distillation Apparatus*, see Fig. 1.

13.2 *Spectrophotometer*, visible range.

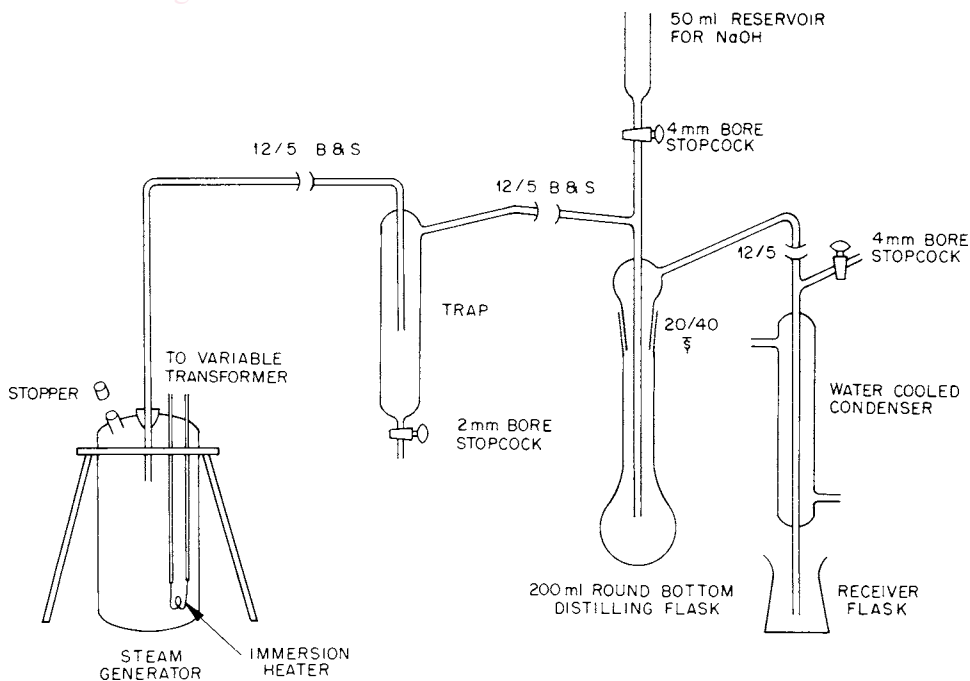

FIG. 1 Distillation Apparatus

14. Reagents

14.1 *Ammonium Chloride (NH₄Cl)*—Dry salt for 2 h at 110 to 120°C.

14.2 *Boric Acid Solution (40 g/L)*—Dissolve 40 g of boric acid (H₃BO₃) in 800 mL of hot water. Cool to approximately 20°C and dilute to 1 L.

14.3 *Hydrochloric Acid (sp gr 1.19)*—Concentrated hydrochloric acid (HCl).

14.4 *Hydrofluoric Acid (48 %)*—Concentrated hydrofluoric acid (HF).

14.5 *Nessler Reagent*—To prepare, dissolve 50 g of potassium iodide (KI) in a minimum of cold ammonia-free water, approximately 35 mL. Add a saturated solution of mercuric chloride (HgCl₂, 22 g/350 mL) slowly until the first slight precipitate of red mercuric iodide persists. Add 400 mL of 9 N sodium hydroxide solution and dilute to 1 L with water, mix, and allow the solution to stand overnight. Decant supernatant liquid and store in a brown bottle.

14.6 *Nitrogen Standard Solution (1 mL = 0.01 mg N)*—Dissolve 3.819 g of NH₄Cl in water and dilute to 1 L. Transfer 10 mL of this solution to a 1-L volumetric flask and dilute to volume with ammonia-free water.

14.7 *Sodium Hydroxide (9 N)*—Dissolve 360 g of sodium hydroxide (NaOH) in ammonia-free water and dilute to 1 L.

14.8 *Sodium Hydroxide (50 %)*—Dissolve sodium hydroxide (NaOH) in an equal weight of water.

14.9 *Water (Ammonia-free)*—To prepare, pass distilled water through a mixed-bed resin demineralizer and store in a tightly stoppered chemical-resistant glass bottle.

15. Precautions

15.1 The use of ammonia or other volatile nitrogenous compounds in the vicinity can lead to serious error. The following precautionary measures should be taken: (1) Clean all glassware and rinse with ammonia-free water immediately prior to use, and (2) avoid contamination of the atmosphere in the vicinity of the test by ammonia or other volatile nitrogenous compounds.

16. Procedure

16.1 Dissolution of Sample:

16.1.1 Transfer a weighed sample in the range from 1.0 to 1.5 g to a 50-mL beaker.

NOTE 2—Crush the pellet samples to a particle size of 1 mm or less in a diamond mortar.

16.1.2 To the sample add 5 mL of HCl and 3 drops of HF. Heat to put sample into solution.

NOTE 3—Concentrated phosphoric acid or mixtures of phosphoric acid and hydrofluoric acids or of phosphoric and sulfuric acids may be used for the dissolution of plutonium dioxide. Such acids may require a purification step in order to reduce the nitrogen blank before being used in this procedure.

16.2 Distillation:

16.2.1 Quantitatively transfer the sample solution to the distilling flask of the apparatus. Add 20 mL of ammonia-free water; then clamp the flask into place on the distillation apparatus (see Fig. 1).

16.2.2 Turn on the steam generator, but do not close with the stopper.

16.2.3 Add 5 mL of 4 % H₃BO₃ solution to a 50-mL graduated flask and position this trap so that the condenser tip is below the surface of the H₃BO₃ solution.

16.2.4 Transfer 20 mL of 50 % NaOH solution to the funnel in the distillation head.

16.2.5 When the water begins to boil in the steam generator, replace the stopper and slowly open the stopcock on the distilling flask to allow the NaOH solution to run into the sample solution.

NOTE 4—The NaOH solution must be added slowly to avoid a violent reaction which may lead to a loss of sample.

16.2.6 Steam distill until 25 mL of distillate has collected in the trap.

16.2.7 Remove the trap containing the distillate from the distillation apparatus and remove the stopper from the steam generator.

16.2.8 Transfer the cooled distillate to a 50-mL volumetric flask.

16.2.9 Prepare a reagent blank solution by following 16.1 through 16.2.8.

16.3 Measurement of Nitrogen:

16.3.1 Add 1.0 mL of Nessler reagent to each of the distillates collected in 16.2.8 and 16.2.9 and dilute to volume with ammonia-free water, mix, and let stand 10 min.

16.3.2 Measure the absorbance of the solutions at 430 nm in a 1-cm cell. Use water as the reference.

16.4 Calibration Curve:

16.4.1 Add 0, 5, 10, 25, 50, 100, and 150 µg of N from the nitrogen standard solution to separate distilling flasks. Then add 5 mL of HCl and 3 drops of HF plus 20 mL of ammonia-free water to each flask.

16.4.2 Process each solution by the procedure in 16.2 through 16.3 (omit 16.2.9).

16.4.3 Correct for the reagent blank reading and plot the absorbance of each standard against the micrograms of nitrogen per 50 mL of solution.

17. Calculation

17.1 From the calibration chart, read the micrograms of nitrogen corresponding to the absorbance of the sample solution.

17.1.1 Calculate the nitrogen content, *N*, micrograms per gram, of the sample as follows:

$$N = (A - B)/W \quad (1)$$

where:

A = micrograms of nitrogen from sample plus reagents,
B = micrograms of nitrogen in blank, and
W = sample mass, g.

18. Precision

18.1 The estimated relative standard deviation for a single test measurement by this test method is 20 % for 3 µg of nitrogen and 3 % for 50 to 90 µg of nitrogen.

CARBON (TOTAL) BY DIRECT COMBUSTION-THERMAL CONDUCTIVITY

19. Scope

19.1 This test method covers the determination of 10 to 200 µg of residual carbon in nuclear-grade plutonium dioxide.

20. Summary of Test Method

20.1 Powdered samples are covered and mixed with an accelerator in carbon-free crucibles and burned with oxygen in an induction heating furnace. Traces of sulfur compounds and water vapor are removed from the combustion products by a purification train, and the resultant carbon monoxide is converted to carbon dioxide. The purified carbon dioxide is trapped on a molecular sieve, eluted therefrom with a stream of helium upon application of heat to the trap, and passed through a thermal conductivity cell. The amount of carbon present, being a function of the integrated change in the current of the detector cell, is read directly from a calibrated digital voltmeter or strip-chart recorder.

21. Interferences

21.1 There are no known interferences not eliminated by the purification system.

22. Apparatus

22.1 *Commercial Combustion Apparatus*, suitable for the carbon determination, is often modified to facilitate maintenance and operation within the glove box which is required for all work with plutonium materials.

22.1.1 *Combustion Apparatus*¹⁰—This apparatus shall consist of an induction furnace suitable for operation at 1600°C, with a purification train, a catalytic furnace, carbon dioxide trap, thermal conductivity cell with appropriate readout equipment, and a regulated supply of oxygen and helium.

22.1.2 *Combustion Tubes*—Quartz combustion tubes with integral baffle shall be used.

22.1.3 *Crucibles*—Expendable alumina or similar refractory crucibles shall be used. The use of crucible covers is optional. Satisfactory operation with covers must be established by analysis of standards. Crucibles and covers (if used) must be ignited at a temperature of 1000°C or higher for a time sufficient to produce constant blank values.

22.1.4 *Accelerators*—Granular tin and tin foil accelerators shall be used as required to obtain satisfactory results. The criterion for satisfactory results is the absence of significant additional carbon release upon re-combustion of the specimen.

22.1.5 *Catalytic Furnace and Tube*—This unit, which is used to ensure complete oxidation of CO to CO₂, consists of a tube containing copper oxide and maintained at a temperature of 300°C by a small furnace.

22.1.6 *Carbon Dioxide Purifiers*—The purifiers that follow the combustion tube must remove finely divided solid metallic oxides and oxides of sulfur and selenium, dry the gases before they enter the CO₂ trap, and protect the absorber from outside

effects. Finely divided solid metal oxides are removed from the gases during their passage through the quartz wool. The SO₂ given off by materials containing sulfur is removed by MnO₂ and any water vapor is absorbed in a tube containing Mg(ClO₄)₂. Hot copper oxide converts carbon monoxide to carbon dioxide. Additional components in the purification train may be required when materials containing very high amounts of sulfur or of halides are being analyzed. The materials used in the purification train must be checked frequently to ensure that their absorbing capacity has not been exhausted.

22.2 *Vibratory Sample Pulverizer Apparatus*,¹¹ capable of reducing ceramic materials to a -100-mesh powder. A stainless steel capsule and mixing ball must be used in order to reduce the contamination of the sample with carbon.

23. Reagents and Materials

23.1 *Sulfuric Acid (sp gr 1.84)*—Concentrated sulfuric acid (H₂SO₄) to be used in the oxygen purification train.

23.2 *Quartz Wool*, to use as a dust trap at top of combustion tube.

23.3 *Standard Materials*—Institute for Standards and Technology (NIST) SRM 131b Low-Carbon Steel (0.0018 % carbon) and SRM 336 Steel (0.567 % carbon) or their replacements.

24. Safety Precautions

24.1 *Samples Containing Plutonium*—Due to the extreme toxicity of plutonium and the certainty that some plutonium will become airborne during the analytical operations, it is mandatory to perform all operations within an approved glove box fitted with off-gas filters capable of sustained operation with dust-laden atmospheres.

25. Sampling

25.1 *Sample Size*—The normal sample size for plutonium dioxide fuel materials shall be 1 g. If necessary, this amount shall be altered as required to contain less than 200 µg of carbon.

25.2 *Sample Preparation*—Pellet or particulate samples shall be reduced to approximately a -100-mesh powder prior to the weighing of the specimens. Exposure of the powdered sample to atmospheric carbon dioxide should be minimized by storage of the powder in a closed vial. Refer to Sections 8 and 10 for guidance in handling plutonium dioxide.

26. Preparation of Apparatus

26.1 *Analysis System Purge*—After having properly set the operating controls of the instrument system, condition the apparatus by combustion of several blanks prepared with the sample crucible and accelerator in the amount to be used with the test specimen analyses. Successive blank values should approach a constant value, allowing for normal statistical fluctuations. The instrument should be adjusted for a 2-min combustion period.

¹⁰ A Leco Low Carbon Analyzer, manufactured and sold by Laboratory Equipment Co., St. Joseph, MI, or equivalent, has been found satisfactory for this purpose.

¹¹ Wig-L-Bug, manufactured and sold by Spex Industries, Inc., Scotch Plains, NJ, has been found satisfactory for this purpose.

27. Calibration

27.1 *Preparation of Standards for Combustion*—Mix a weighed portion of an accelerator and a weighed portion of approximately 1 g of NIST 131b in each of three sample crucibles. Repeat with NIST 336, using approximately 30 to 40 mg.

27.1.1 The NIST 336 steel is assigned a carbon content 0.567 % (5670 µg/g). Therefore, amounts ranging up to approximately 40 mg are used for standardization. Weigh the steel into a tared container (a small nickel-sample boat if convenient), obtaining the mass to the nearest 0.01 mg. Transfer the chips to a 30-mm square of aluminum foil (previously acetone washed), and fold the foil into a wrapper with the aid of stainless steel tongs and spatulas. The foil should not be touched by the hands. Place the wrapped standard in a numbered glass vial and transfer to the analyzer glove box.

27.2 *Combustion of Standards*—Load and combust the standards and record the results. Adjust the calibration controls in such a way as to produce the correct readout value on the direct readout meter. Combust additional standards as required to produce the correct direct readout. As an alternative, consider the readout digits as arbitrary numbers and prepare a calibration curve of known micrograms of carbon *versus* the readout value. A strip chart recorder connected to present the integrated value of the carbon dioxide response signal is helpful in detecting and correcting for analyzer drift and noise.

28. Procedure

28.1 Pulverize the pellet samples for 15 s in the stainless steel capsule of the sample pulverizer.

28.2 Weigh a sample crucible containing the required amount of accelerator to the nearest 0.01 g.

28.3 Transfer the sample powder, not to exceed 1 g or of such size as to give not more than 200 µg of carbon, to the crucible. Weigh the crucible and contents to the nearest 0.01 g and find the specimen mass by difference.

28.4 Mix the specimen powder and the accelerator with a stainless steel spatula.

28.5 Load the sample crucible into the furnace and combust the specimen for 2 min.

28.6 Remove the sample crucible and examine for evidence of incomplete combustion. The crucible contents should be a uniform fused mass.

29. Calculation

29.1 Calculate the concentration of carbon in the sample by dividing the net micrograms of carbon found by the sample mass, expressed in grams, as follows:

$$C, \mu\text{g/g} = (C_s - C_b)/W \quad (2)$$

where:

C_s = micrograms of carbon in the sample and reagents,

C_b = micrograms of carbon in reagent blank, and,

W = grams of oxide sample.

30. Precision

30.1 The relative standard deviation of this test method is approximately 10 % for a concentration of 30 µg of carbon/g of sample.

TOTAL CHLORINE AND FLUORINE BY PYROHYDROLYSIS

31. Scope

31.1 This test method covers the determination of 5 to 100 µg/g of chlorine and 1 to 100 µg/g of fluorine in 1-g samples of nuclear-grade plutonium dioxide.

32. Summary of Test Method

32.1 A 1 to 2-g sample of plutonium dioxide is pyrohydrolyzed at 950°C with a stream of moist air or oxygen. The halogens are volatilized as acids during the pyrohydrolysis and are trapped as chloride and fluoride in a buffered solution. Several procedures are outlined for the measurement of chloride and fluoride in the resultant condensate. Chloride is measured by spectrophotometry, microtitrimetry, or with ion-selective electrodes and fluoride with ion-selective electrodes or spectrophotometry (6,7).

33. Interferences

33.1 Bromide, iodide, cyanide, sulfide, and thiocyanate, if present in the condensate, would interfere with the spectrophotometric and microtitrimetric measurement of chloride. Bromide, iodide, sulfide, and cyanide interfere in the measurement of chloride with ion-selective electrodes, but have very little effect upon the measurement of fluoride with selective electrodes.

34. Apparatus (see Fig. 2 and Fig. 3)

34.1 *Gas Flow Regulator*—A flowmeter and a rate controller to adjust the flow of sparge gas between 1 to 3 L/min.

34.2 *Hot Plate*—A heater used to keep the water bubbler temperature between 50 and 90°C.

34.3 *Furnace*—A tube furnace that is capable of maintaining a temperature from 900 to 1000°C. The bore of the furnace should be about 32 mm (1¼ in.) in diameter and about 305 mm (12 in.) in length.

34.4 *Reactor Tube*, made from fused-silica or platinum. The delivery tube should be a part of the exit end of the reactor tube and be within 51 mm (2 in.) of the furnace (see Fig. 2 for proper tube positioning).

34.5 *Combustion Boats*, made from fused-silica or platinum. A boat about 102 mm (4 in.) long is made by cutting lengthwise a silica tube 20 mm in diameter and flattening one end to provide a handle. A fused-silica inner sleeve for the reactor tube can facilitate the movement of the boat into the tube, prevent spillage, and thus prolong the life of the combustion tube.

34.6 *Collection Vessel*—A plastic graduate or beaker designed to maintain most of the scrubber solution above the tip of the delivery tube.

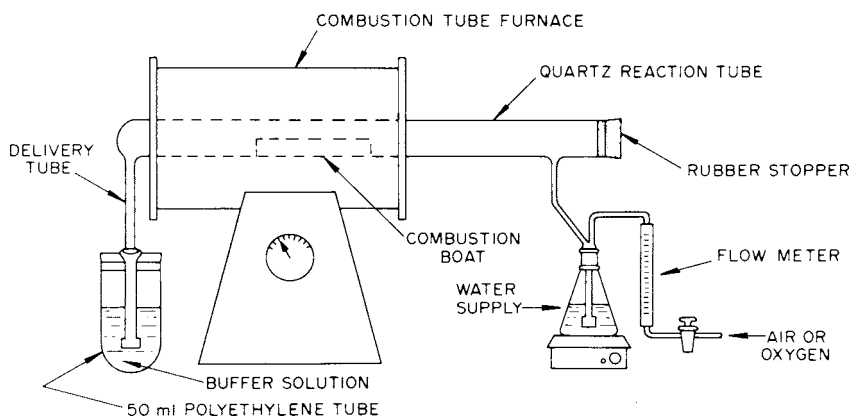

FIG. 2 Pyrohydrolysis Apparatus

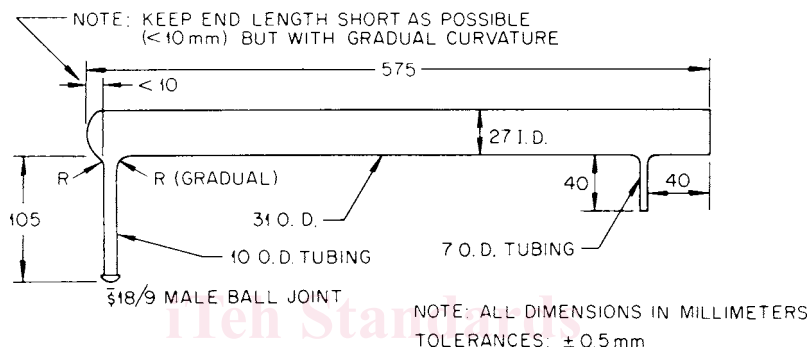

FIG. 3 Quartz Reaction Tube

34.7 Automatic Chloride Titrator.¹²

34.8 Ion-Selective Electrodes, chloride and fluoride.

34.9 Reference Electrode—Use a double-junction type electrode such as mercuric sulfate, sleeve-junction type electrode. Do not use a calomel electrode.

34.10 Spectrophotometer, ultraviolet to visible range and absorption cells. For a discussion on spectrophotometers and their use see Practice E60.

34.11 pH Meter, with an expanded scale having a sensitivity of 1 mV.

35. Reagents

35.1 Accelerator—Halogen-free uranium oxide (U_3O_8) powder used as a flux to enhance the release of chloride and fluoride.

35.2 Air or Oxygen, compressed.

35.3 Buffer Solution (0.001 N)—Prepare by adding 50 μ L of concentrated glacial acetic acid (CH_3CO_2H , sp gr 1.05) and 0.1 g of potassium acetate ($KC_2H_3O_2$) to 1 L of water.

35.4 Chloride Standard Solution (1 mL = 1 mg Cl)—Dissolve 1.65 g of sodium chloride (NaCl) in water and dilute to 1 L.

35.5 Chloride, Standard Solution (1 mL = 5 μ g Cl)—Prepare by diluting 5 mL of chloride solution (1 mL = 1 mg Cl) to 1 L with water.

35.6 Ferric Ammonium Sulfate Solution (0.25 M in 9 M nitric acid)—Dissolve 12 g of ferric ammonium sulfate ($Fe(NH_4)(SO_4)_2 \cdot 12 H_2O$) in 58 mL of concentrated nitric acid (HNO_3 , sp gr 1.42) and dilute to 100 mL with water.

35.7 Fluoride, Standard Solution (1 mL = 1 mg F)—Dissolve 2.21 g of sodium fluoride (NaF) in water and dilute to 1 L.

35.8 Fluoride, Standard Solution (1 mL = 10 μ g F)—Dilute 10 mL of fluoride solution (1 mL = 1 mg F) to 1 L with water.

35.9 Gelatin Solution—Add 6.2 g of dry gelatin mixture (60 parts of dry gelatin + 1 part of thymol blue + 1 part of thymol) to 1 L of hot water and heat with stirring until solution is clear.

35.10 Lanthanum-Alizarin Complexone¹³—Dissolve 0.048 g of alizarin complexone (3-aminomethylalizarin-*N,N*-diacetic acid) in 100 μ L of concentrated ammonium hydroxide (NH_4OH), 1 mL of an ammonium acetate solution ($NH_4C_2H_3O_2$, 20 mass %), and 5 mL of water. Filter the solution through a high-grade, rapid-filtering, qualitative filter paper. Wash the paper with a small volume of water, and add 8.2 g of anhydrous sodium acetate ($NaC_2H_3O_2$) and 6 mL of concentrated glacial acetic acid (CH_3CO_2H , sp gr 1.05) to the filtrate. Add 100 mL of acetone while swirling the filtrate. Add 0.040 g of lanthanum oxide (La_2O_3) dissolved in 2.5 mL of warm 2 N HCl. Mix the two solutions and dilute to 200 mL. After 30 min readjust the solution volume.

NOTE 5—A 0.1-g/L solution is prepared by dissolving 100 mg of the

¹² A Cotlove Titrator, sold by American Instrument Co., Silver Spring, MD, or by Buchler Instruments, Inc., Fort Lee, NJ, or equivalent, has been found satisfactory for this purpose.

¹³ The reagent is available commercially under the name Amadac-F.

reagent in water and diluting with isopropyl alcohol to obtain a 60 % alcoholic medium.

35.11 *Mercuric Thiocyanate Solution*—Prepare a saturated solution by adding 0.3 g of mercuric thiocyanate ($\text{Hg}(\text{SCN})_2$) to 100 mL of 95 % ethanol. Shake the mixture thoroughly for maximum dissolution of the solid. Filter the solution.

35.12 *Nitric Acid-Acetic Acid Solution* (1 N Nitric Acid and 4 N Acetic Acid)—Prepare by adding 64 mL of nitric acid (HNO_3 , sp gr 1.42) to a 1-L volumetric flask which contains 500 mL of water. Swirl the solution in the flask and add 230 mL of acetic acid ($\text{CH}_3\text{CO}_2\text{H}$, sp gr 1.05). Dilute the solution with water to 1 L.

36. Pyrohydrolysis Procedure

36.1 Prepare the pyrohydrolysis apparatus for use as follows:

36.1.1 Regulate the gas flow between 1 and 3 L/min.

36.1.2 Adjust the temperature of the hot plate to heat the water to approximately 90°C.

36.1.3 Adjust the temperature of the furnace to $950 \pm 50^\circ\text{C}$.

36.1.4 Add 15 mL of buffer solution to the collection vessel and place around the delivery tube.

36.2 Weigh accurately, 1 to 2 g of the powdered plutonium dioxide and transfer to a combustion boat. If an accelerator, U_3O_8 , is used mix 4 g with the sample before loading into the boat.

36.3 Place the boat containing the sample into the reactor tube and quickly close the tube. The boat should be in the middle of the furnace.

36.4 Allow the pyrohydrolysis to proceed for at least 30 min.

36.5 Remove the collection vessel and wash down the delivery tube with some buffer solution. Dilute the solution to 25 mL with the acetate buffer. Determine the chloride and fluoride by one or more of the measurement procedures covered in Section 37.

36.6 Remove the boat from the reactor tube and dispose of the sample residue.

36.7 Run a pyrohydrolysis blank with halogen-free U_3O_8 by following the procedures, given in 36.3-36.6.

37. Measurement of Chloride and Fluoride

37.1 *Determination of Chloride by Spectrophotometry:*

37.1.1 Prepare a calibration curve by adding 0, 1, 2, 5, and 10 mL of the chloride solution (1 mL = 5 μg Cl) to separate 25-mL flasks. Dilute each to 20 mL with buffer solution, and add 2 mL of the ferric ammonium sulfate solution and 2 mL of the mercuric thiocyanate solution. Mix the solution and dilute to 25 mL with water. Mix the solutions again and allow them to stand 10 min. Transfer some of the solution from the flask to a 1-cm absorption cell and read the absorbance at 460 nm using water as the reference liquid. Plot the micrograms of Cl per 25 mL *versus* the absorbance reading.

37.1.2 To determine Cl in the pyrohydrolysis condensate transfer 15 mL of the buffer solution to a 25-mL volumetric flask. Add 2 mL of the ferric ammonium sulfate solution and 2 mL of the mercuric thiocyanate solution. Mix the solutions, dilute to volume with water, and mix again. Allow the solution to stand 10 min. Transfer some of the solution from the flask to

a 1-cm absorption cell and read the absorbance at 460 nm *versus* water as the reference. Read the micrograms of Cl present from the calibration curve.

NOTE 6—A calibration curve can be prepared by drying measured aliquots of a chloride solution on some halogen-free U_3O_8 and proceeding through pyrohydrolysis steps.

37.1.3 Calculate the chlorine, Cl, $\mu\text{g/g}$, as follows:

$$\text{Cl, } \mu\text{g/g} = (A - B)V_1/WV_2 \quad (3)$$

where:

A = micrograms of chlorine in aliquot measured,

B = micrograms of chlorine in blank,

W = grams of PuO_2 pyrohydrolyzed,

V_1 = millilitres of scrub solution, and

V_2 = aliquot of scrub solution analyzed, mL.

37.2 *Determination of Chloride by Amperometric Microtitrimetry:*

37.2.1 Calibrate the titrimeter by adding 5 mL of the buffer solution, 1 mL of the nitric acid-acetic acid solution, and 2 drops of the gelatin solution to a titration cell. Pipet 50 μL of the chloride solution (1 mL = 1 mL Cl) into the titration cell. Place the cell on the chloride titrator and follow the manufacturer's suggested sequence of operations for chloride (Note 7). Record the time required to titrate 50 μg . Run a reagent blank titration.

NOTE 7—The Cl-analyzer generates silver ions which react to precipitate the chloride ion. The instrument uses an amperometric end point to obtain an automatic shut-off of the generating current at a pre-set increment of indicator current. Since the rate of generating silver ion is constant, the amount of chloride precipitated is proportional to the time required for the titration.

37.2.2 Determine Cl in the pyrohydrolysis-scrub solution by adding 5 mL to a titration cell which contains 1 mL of the nitric acid-acetic acid solution and 2 drops of the gelatin solution.

37.2.3 Place the cell in position on the titrator. Start the titrator and record the time required to titrate the Cl present.

37.2.4 Calculate the chlorine as follows:

$$\text{Cl, } \mu\text{g/g} = V_1F(T_s - T_B)/V_2W \quad (4)$$

where:

V_1 = volume of scrub solutions = 25,

V_2 = aliquot of scrub solution analyzed, mL,

F =

$$\frac{\mu\text{Cl standard titrated}}{\text{titration time of standard} - \text{titration time of blank}}$$

or

$$F = 50/(T_{\text{Cl}} - T_B), \quad (5)$$

where:

T_s = titration time to titrate sample and blank,

T_{Cl} = titration time to titrate 50 μg of Cl and blank,

T_B = titration time to titrate reagent blank, and

W = grams of PuO_2 pyrohydrolyzed.

37.3 *Determination of Chloride and Fluoride with Ion-Selective Electrodes:*

37.3.1 Preparation of the calibration curves requires the assembly of the meter and the ion-selective electrode with a suitable reference electrode. From these standards take the millivolt readings for each ion-selective electrode and plot on semi-log paper the halogen content per 25 mL *versus* millivolts. Prepare a series of standards in acetate buffer solution by pipeting aliquots of the halogen standards into separate 25-mL flasks ranging in concentrations as follows:

Cl from 10 to 100 µg/25 mL

F from 5 to 100 µg/25 mL

37.3.2 Determine the Cl and F in the scrub solution from the pyrohydrolysis by using the appropriate ion-selective electrode. Record the micrograms of Cl or F from the calibration curve and calculate the halide as follows:

$$\text{Cl or F, } \mu\text{g/g} = (H_s - H_b)/W \quad (6)$$

where:

H_s = halide in aliquot of scrub solution + blank, µg,

H_b = halide in pyrohydrolysis blank, µg, and

W = sample mass, g.

37.4 Determination of Fluoride by Spectrophotometry:

37.4.1 Prepare a calibration curve by adding to separate 10-mL flasks 0, 50, 100, 200, 500, and 1000 µL of the fluoride solution (1 mL = 10 µg F). Add 2.0 mL of the lanthanum-alizarin complexone solution and dilute to volume with water. Mix and let stand 1 h. Read the absorbance at 622 nm *versus* the reagent blank. Plot the micrograms of F per 10 mL *versus* absorbance reading.

37.4.2 Measure F in the pyrohydrolysis scrub solution by pipeting 5 mL into a 10-mL volumetric flask. Add 2.0 mL of the lanthanum-alizarin complexone and dilute to volume. Mix and let stand 1 h. Read the absorbance at 622 nm *versus* a reagent blank and obtain the fluoride content from the calibration curve.

37.4.3 Calculate the fluorine concentration, F , in the PuO₂ sample as follows:

$$F, \mu\text{g/g} = [(F_s - F_b)/W] \times V_1/V_2 \quad (7)$$

where:

F_s = fluorine in aliquot of scrub solution + the blank, µg,

F_b = micrograms of fluorine in pyrohydrolysis blank,

V_1 = total volume of the scrub solution, mL,

V_2 = aliquot of scrub solution analyzed, mL, and

W = grams of PuO₂ sample.

38. Precision

38.1 The relative standard deviations for the measurements of fluorine are approximately 7 % for the range from 5 to 50 µg/g and 10 % for the range from 1 to 5 µg/g. The relative standard deviations for the measurements of chlorine vary from 5 % at the 5 to 50-µg/g level up to 10 % below the 5-µg/g range.

SULFUR BY DISTILLATION SPECTROPHOTOMETRY

39. Scope

39.1 This test method covers the determination of sulfur in the concentration range from 10 to 600 µg/g for samples of nuclear-grade plutonium dioxide powders or pellets.

40. Summary of Test Method

40.1 Sulfur is measured spectrophotometrically as Lauth's Violet following its separation by distillation as hydrogen sulfide (8). Higher oxidation states of sulfur are reduced to sulfide by a hypophosphorous-hydriodic acid mixture, the hydrogen sulfide is distilled into zinc acetate, and *p*-phenylenediamine and ferric chloride are added to form Lauth's Violet. The quantity of sulfur is calculated from the measured absorbance at 595 nm and the absorbance per microgram of sulfur obtained for calibration materials having known sulfur contents. The relative standard deviation ranges from 12 to 3 % for the concentration range from 10 to 600 µg of sulfur per gram of sample.

41. Interference

41.1 None of the impurity elements interfere when present in amounts up to twice their specification limits for plutonium dioxide.

42. Apparatus

42.1 *Boiling Flask*, adapted with a gas inlet line and fitted with a water-cooled condenser and delivery tube.

42.2 *Spectrophotometer*, with matched 1-cm cells.

42.3 *Sulfur*, distillation apparatus (see Fig. 4).

43. Reagents

43.1 *Argon Gas*, cylinder.

43.2 *Ferric Chloride Solution*, 2 % FeCl₃ in 6 M HCl.

43.3 *Formic Acid* (HCOOH), redistilled.

43.4 *Hydriodic-Hypophosphorous Acid Reducing Mixture*—Mix 400 mL of 7.6 M hydriodic acid (HI) with 200 mL of hypophosphorous acid (H₃PO₂, 31 %) and boil under reflux for 30 min with a continuous argon sparge. Test for sulfur content by analyzing a 15-mL aliquot as described in procedure. Reboil if necessary to reduce the sulfur content to below 1 µg/mL.

43.5 *Hydrochloric Acid* (0.6 M)—Dilute 10 mL of 12 M hydrochloric acid (HCl) to 200 mL with water.

43.6 *Hydrochloric Acid* (3 M)—Dilute 50 mL of 12 M HCl to 200 mL with water.

43.7 *Hydrochloric Acid* (6 M)—Dilute 100 mL of 12 M HCl to 200 mL with water.

43.8 *Hydrochloric Acid* (12 M)—Analyze an aliquot of HCl (sp gr 1.19) for sulfur content. Use only a reagent in which

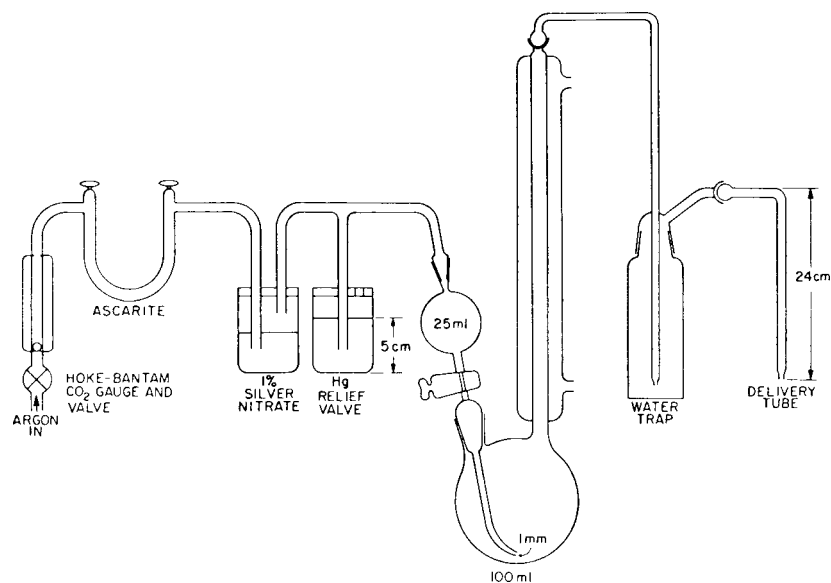

FIG. 4 Sulfur Distillation Apparatus

the sulfur content is less than 1 $\mu\text{g}/10\text{ mL}$ and prepare the diluted acids with this reagent.

43.9 *Hydrofluoric Acid* (HF), 48 %.

43.10 *Hydroxylamine Hydrochloride* ($\text{NH}_2\text{OH}\cdot\text{HCl}$), 20 % aqueous solution.

43.11 *Nitric Acid* (15.6 M), 70 % HNO_3 .

43.12 *p*-phenylenediamine (1 %)—Dissolve 1 g of *p*-phenylenediamine in 100 mL of 0.6 M HCl.

43.13 *Silver Nitrate* (AgNO_3), 1 % aqueous solution.

43.14 *Sulfur Calibration Solution* (1 mL = 5 $\mu\text{g S}$)—Dissolve 2.717 g of dry potassium sulfate (K_2SO_4) in water and dilute to 1 L. Dilute 2.00 mL to 200 mL with water.

43.15 *Zinc Acetate Solution* (4 %)—Dissolve 20 g of zinc acetate ($\text{Zn}(\text{C}_2\text{H}_3\text{O}_2)_2$) in 500 mL of water and filter.

44. Calibration

44.1 Use aliquots of standard sulfur solution (1 mL = 5 $\mu\text{g S}$) to test the method and check the apparatus. Ideally, blends of oxides and sulfur (20 to 600 $\mu\text{g S/g}$) should be analyzed to simulate actual sample conditions.

44.2 Prepare a calibration curve of absorbance *versus* sulfur (using aliquots of the sulfur standard solution) covering a concentration range from 5 to 50 $\mu\text{g}/50\text{ mL}$.

45. Procedure

45.1 Pulverize plutonium dioxide pellets in a mixer-mill with a tungsten carbide container and a tungsten carbide ball.

45.2 Transfer a sample, weighed to $\pm 0.2\text{ mg}$, to a 20-mL beaker or a 30-mL platinum dish. Use a 0.5-g sample when the expected level of sulfur is 100 $\mu\text{g/g}$ or less.

45.3 Add 5 mL of 15.6 M HNO_3 and 3 to 4 drops of 28 M HF and heat the solution below its boiling point. Watch glasses or platinum lids are recommended to avoid spattering.

45.4 Add additional amounts of HNO_3 and HF acids until the sample dissolves.

NOTE 8—The sealed-tube technique (5) is an alternate method that may be used to advantage for the dissolution of some samples.

45.5 Evaporate the solution just to dryness, but do not fume intensely to dryness.

45.6 Add dropwise 0.5 mL of formic acid, and heat the solution at a moderate heat until the vigorous reaction subsides and gases are no longer evolved.

NOTE 9—The reduction of HNO_3 by formic acid is vigorous. Keep the dish or beaker covered with a watch glass between additions of formic acid.

45.7 Rinse the cover glass with water. Add 0.5 mL of formic acid and slowly evaporate the rinse and sample solution to dryness.

NOTE 10—Nitrate must be completely removed because it reacts explosively with the reducing acid.

45.8 Dissolve the residue in a minimum volume of 3 M HCl and dilute to approximately 5 mL with water. Heat to just below the boiling point and add 20 drops of hydroxylamine solution (Pu (III) blue is formed).

45.9 Add 30 mL of water to the trap of the distillation apparatus (Fig. 4) and insert the trap tube.

45.10 Pipet 10.0 mL of zinc acetate solution into a 50-mL glass-stoppered graduated cylinder, dilute to 35 mL with water, and position the cylinder so the end of the delivery tube is immersed in the solution.

45.11 Transfer the sample solution (71.8), with a minimum of water rinses, to the distillation flask and insert the reducing-acid delivery tube.

45.12 Add 15 mL of the reducing acid mixture and 10 mL of 12 M HCl to the delivery bulb, insert the argon sweep gas tube, and start the flow of the reducing acid mixture to the distillation flask.

45.13 Adjust the flow rate of argon to 100 $\text{cm}^3\text{ min}$; then turn on the heating mantle and boil the solution for 35 min.