



SLOVENSKI STANDARD
SIST EN 500-4:2007+A1:2009

01-maj-2009

DfYa] b]glfc]nU[fUXb`c`Wgh!`JUfbcgh!(`"XY`DcgYVbY`nU hYj Y`nUglfc`Y`nU
_ca dU_hfUb`Y`HJ

Mobile road construction machinery - Safety - Part 4: Specific requirements for
compaction machines

Bewegliche Straßenbaumaschinen - Sicherheit - Teil 4: Besondere Anforderungen an
Verdichtungsmaschinen

Machines mobiles pour la construction des routes - Sécurité - Partie 4: Prescriptions
spécifiques pour compacteurs

ITeh STANDARD PREVIEW
(standards.iteh.ai)
<https://standards.iteh.ai/catalog/standards/sist/a8509ef8-8bab-4d12-adad-c2f260b6d30b/sist-en-500-4-2007a1-2009>

Ta slovenski standard je istoveten z: EN 500-4:2006+A1:2009

ICS:

93.080.10 Gradnja cest Road construction

SIST EN 500-4:2007+A1:2009 en,fr

iTeh STANDARD PREVIEW
(standards.iteh.ai)

[SIST EN 500-4:2007+A1:2009](https://standards.iteh.ai/catalog/standards/sist/a8509ef8-8bab-4d12-adad-c2f260b6d30b/sist-en-500-4-2007a1-2009)

<https://standards.iteh.ai/catalog/standards/sist/a8509ef8-8bab-4d12-adad-c2f260b6d30b/sist-en-500-4-2007a1-2009>

EUROPEAN STANDARD

EN 500-4:2006+A1

NORME EUROPÉENNE

EUROPÄISCHE NORM

March 2009

ICS 93.080.10

Supersedes EN 500-4:2006

English Version

Mobile road construction machinery - Safety - Part 4: Specific requirements for compaction machines

Machines mobiles pour la construction des routes -
Sécurité - Partie 4: Prescriptions spécifiques pour
compacteurs

Bewegliche Straßenbaumaschinen - Sicherheit - Teil 4:
Besondere Anforderungen an Verdichtungsmaschinen

This European Standard was approved by CEN on 17 August 2006 and includes Amendment 1 approved by CEN on 15 February 2009.

CEN members are bound to comply with the CEN/CENELEC Internal Regulations which stipulate the conditions for giving this European Standard the status of a national standard without any alteration. Up-to-date lists and bibliographical references concerning such national standards may be obtained on application to the CEN Management Centre or to any CEN member.

This European Standard exists in three official versions (English, French, German). A version in any other language made by translation under the responsibility of a CEN member into its own language and notified to the CEN Management Centre has the same status as the official versions.

CEN members are the national standards bodies of Austria, Belgium, Bulgaria, Cyprus, Czech Republic, Denmark, Estonia, Finland, France, Germany, Greece, Hungary, Iceland, Ireland, Italy, Latvia, Lithuania, Luxembourg, Malta, Netherlands, Norway, Poland, Portugal, Romania, Slovakia, Slovenia, Spain, Sweden, Switzerland and United Kingdom.

[SIST EN 500-4:2007+A1:2009](https://standards.iteh.ai/catalog/standards/sist/a8509ef8-8bab-4d12-adad-c2f260b6d30b/sist-en-500-4-2007a1-2009)

<https://standards.iteh.ai/catalog/standards/sist/a8509ef8-8bab-4d12-adad-c2f260b6d30b/sist-en-500-4-2007a1-2009>



EUROPEAN COMMITTEE FOR STANDARDIZATION
COMITÉ EUROPÉEN DE NORMALISATION
EUROPÄISCHES KOMITEE FÜR NORMUNG

Management Centre: Avenue Marnix 17, B-1000 Brussels

Contents

	Page
Foreword.....	4
Introduction	5
1 Scope	6
2 Normative references	6
3 Terms and definitions	7
4 List of significant hazards	8
5 Safety requirements and/or protective measures	8
5.1 Lighting, signalling and marking lights and reflex-reflector devices.....	8
5.2 Operation and handling	8
5.3 Operator's station	10
5.4 Operator's seat.....	10
5.5 Controls and indicators	10
5.6 Starting	10
5.7 Stopping	10
5.8 Access system to operator's station and to maintenance points	11
5.9 Hand-guards on explosion hammers	12
5.10 Roll-over protective structure (ROPS).....	12
5.11 Noise and vibration.....	13
6 Verification of safety requirements and/or protective measures	13
7 Information for the user	14
7.1 Warning signals and devices	14
7.2 Instruction handbook	14
7.3 Marking	14
Annex A (normative) Remote infrared controls for rollers with attending operator	16
Annex B (normative) Noise test code for hand-guided and remote-controlled vibratory ground compaction machines	19
Annex C (normative) Measurement of the hand-arm vibration of hand-guided vibratory ground compaction machines	30
Annex D (normative) Noise test code for rollers for ride-on operation.....	36
Annex ZA (informative) Relationship between this European Standard and the Essential Requirements of EC Directive 98/37/EC	41
Annex ZB (informative) $\overline{A1}$ Relationship between this European Standard and the Essential Requirements of EU Directive 2006/42/EC $\overline{A1}$.....	42
Bibliography	43
Figures	
Figure 1 — Vertical swinging of single-drum walk-behind rollers	9
Figure 2 — Position of the safety device at pedestrian-controlled rollers	9
Figure 3 — Minimum clearance of lower limbs at access to the operator's station on machines with articulated steering	12
Figure 4 — Deflection-limiting volume, front view, side view.....	13

Figure $\boxed{A_1}$ B.1 $\langle A_1 \rangle$ — Arrangement of test positions for hand-guided machines	20
Figure $\boxed{A_1}$ B.2 $\langle A_1 \rangle$ — Arrangement of test positions for remote-controlled machines	21
Figure $\boxed{A_1}$ B.3 $\langle A_1 \rangle$ — Grading-size diagram of the material to be compacted (gravel)	25
Figure $\boxed{A_1}$ B.4 $\langle A_1 \rangle$ — Test site and arrangement with test track	26
Figure $\boxed{A_1}$ C.1 $\langle A_1 \rangle$ — Directions of measurement and examples for attachment of the acceleration transducer	32
Figure $\boxed{A_1}$ C.2 $\langle A_1 \rangle$ — Arrangement of the coupling device on the drawbar.....	33
Figure $\boxed{A_1}$ D.1 $\langle A_1 \rangle$ — Basic length L	37
Figure $\boxed{A_1}$ D.2 $\langle A_1 \rangle$ — Microphone positions	37

Tables

Table $\boxed{A_1}$ B.1 $\langle A_1 \rangle$ — Coordinates of microphones	22
Table $\boxed{A_1}$ B.2 $\langle A_1 \rangle$ — Operating conditions	27
Table $\boxed{A_1}$ B.3 $\langle A_1 \rangle$ — Uncertainties	27

ITeH STANDARD PREVIEW
(standards.iteh.ai)

[SIST EN 500-4:2007+A1:2009](https://standards.iteh.ai/catalog/standards/sist/a8509ef8-8bab-4d12-adad-c2f260b6d30b/sist-en-500-4-2007a1-2009)

<https://standards.iteh.ai/catalog/standards/sist/a8509ef8-8bab-4d12-adad-c2f260b6d30b/sist-en-500-4-2007a1-2009>

EN 500-4:2006+A1:2009 (E)**Foreword**

This document (EN 500-4:2006+A1:2009) has been prepared by Technical Committee CEN/TC 151 “Building material construction machinery and equipment — Safety”, the secretariat of which is held by DIN.

This European Standard shall be given the status of a national standard, either by publication of an identical text or by endorsement, at the latest by September 2009, and conflicting national standards shall be withdrawn at the latest by December 2009.

This document includes Amendment 1, approved by CEN on 2009-02-15.

This document supersedes A1 EN 500-4:2006 A1.

The start and finish of text introduced or altered by amendment is indicated in the text by tags A1 A1.

This document has been prepared under a mandate given to CEN by the European Commission and the European Free Trade Association and supports essential requirements of EU Directive(s).

A1 For relationship with EU Directive(s), see informative Annexes ZA and ZB, which are integral parts of this document. A1

iTeh STANDARD PREVIEW
(standards.iteh.ai)

EN 500 “Mobile road construction machinery — Safety” comprise the following parts:

- Part 1: Common requirements;
- Part 2: Specific requirements for road-milling machines;
<https://standards.iteh.ai/catalog/standards/sist/a8509ef8-8bab-4d12-adad-c2f260b6d30b/sist-en-500-4-2007a1-2009>
- Part 3: Specific requirements for soil-stabilising machines and recycling machines;
- Part 4: Specific requirements for compaction machines;
- Part 6: Specific requirements for paver-finishers.

According to the CEN/CENELEC Internal Regulations, the national standards organizations of the following countries are bound to implement this European Standard: Austria, Belgium, Bulgaria, Cyprus, Czech Republic, Denmark, Estonia, Finland, France, Germany, Greece, Hungary, Iceland, Ireland, Italy, Latvia, Lithuania, Luxembourg, Malta, Netherlands, Norway, Poland, Portugal, Romania, Slovakia, Slovenia, Spain, Sweden, Switzerland and United Kingdom.

Introduction

This European Standard is a type C standard as stated in EN ISO 12100-1.

The machinery concerned and the extent to which hazards, hazardous situations and events are covered are indicated in the scope of this European Standard.

When provisions of this type C standard are different from those which are stated in type A or B standards, the provisions of this type C standard take precedence over the provisions of the other standards, for machines that have been designed and built according to the provisions of this type C standard.

iTeh STANDARD PREVIEW (standards.iteh.ai)

[SIST EN 500-4:2007+A1:2009](https://standards.iteh.ai/catalog/standards/sist/a8509ef8-8bab-4d12-adad-c2f260b6d30b/sist-en-500-4-2007a1-2009)

<https://standards.iteh.ai/catalog/standards/sist/a8509ef8-8bab-4d12-adad-c2f260b6d30b/sist-en-500-4-2007a1-2009>

EN 500-4:2006+A1:2009 (E)**1 Scope**

This part of EN 500 specifies the safety requirements for compaction machines as defined in Clause 3 and deals with all significant hazards, hazardous situations and events relevant to compaction machines, when they are used as intended and under conditions of misuse which are reasonably foreseeable.

This document specifies additional requirements to and/or exceptions from EN 500-1 "Common requirements".

2 Normative references

The following referenced documents are indispensable for the application of this document. For dated references, only the edition cited applies. For undated references, the latest edition of the referenced document (including any amendments) applies.

EN 500-1:2006, *Mobile road construction machinery — Safety — Part 1: Common requirements*

EN 954-1:1996, *Safety of machinery — Safety-related parts of control systems — Part 1: General principles for design*

A1 deleted text **A1**

A1 EN 60204-1:2006 **A1**, *Safety of machinery — Electrical equipment of machines — Part 1: General requirements* **A1** (IEC 60204-1:2005, modified) **A1**

EN ISO 3164:1999, *Earth-moving machinery — Laboratory evaluations of protective structures — Specifications for deflection-limiting volume (ISO 3164:1995)*

A1 EN ISO 3450:1996, *Earth-moving machinery — Braking systems of rubber-tyred machines — Systems and performance requirements and test procedures (ISO 3450:1996)* **A1**

A1 EN ISO 3471:2008, *Earth-moving machinery — Roll-over protective structures — Laboratory tests and performance requirements (ISO 3471:2008)* **A1**

EN ISO 3744:1995, *Acoustics — Determination of sound power levels of noise sources using sound pressure — Engineering method in an essentially free field over a reflecting plane (ISO 3744:1994)*

EN ISO 6683:2005, *Earth-moving machinery — Seat belts and seat belt anchorages — Performance requirements and tests (ISO 6683:2005)*

EN ISO 11201:1995, *Acoustics — Noise emitted by machinery and equipment — Measurement of emission sound pressure levels at a work station and at other specified positions — Engineering method in an essentially free field over a reflecting plane (ISO 11201:1995)*

EN ISO 12100-1:2003, *Safety of machinery — Basic concepts, general principles for design — Part 1: Basic terminology, methodology (ISO 12100-1:2003)*

EN 60664, *Insulation coordination for equipment within low-voltage systems*

EN ISO 20643:2005, *Mechanical vibration — Hand-held and hand-guided machinery — Principles for evaluation of vibration emission (ISO 20643:2005)*

ISO 9248:1992, *Earth-moving machinery — Units for dimensions, performance and capacities, and their measurement accuracies*

ISO 17063:2003, *Earth-moving machinery — Braking systems of pedestrian-controlled machines — Performance requirements and test procedures*

3 Terms and definitions

For the purposes of this document, the terms and definitions given in EN ISO 12100-1:2003 and the following apply.

3.1

compaction machine

machine which compacts materials, e.g. rock fills, soil or asphalt material, through a rolling and/or vibrating action of the wheel bodies or by tamping and vibrating movements of vibratory plates or rammers. It may be self-propelled, towed, pedestrian-controlled or attachment-type machines. The wheel bodies (metallic cylinders) can be rubber-coated or fitted with pads.

Compaction machines are subdivided as follows:

3.1.1

roller for ride-on operators

self-propelled compaction machine with one or more metallic cylindrical bodies (drums) or rubber tyres; the operator's station is an integral part of the machine

3.1.1.1

single-drum roller

self-propelled compaction machine with one vibrating metallic cylindrical body (drum) and two rubber tyres

3.1.1.2

tandem roller

self-propelled compaction machine with one metallic cylindrical body (drum) in the front and one in the rear. They can be either static or vibrating and they can be split

3.1.1.3

combined roller

self-propelled compaction machine with one or more metallic cylindrical body (drum) and more than two rubber tyres

3.1.1.4

three-wheel roller

self-propelled compaction machine with one metallic body (drum) in the front (or rear) and two in the rear (or front). The drums can be split

3.1.1.5

pneumatic-tyre roller

self-propelled compaction machine with three or more tyres in the front and the rear

3.1.2

pedestrian-controlled roller

self-propelled compaction machine with one or more metallic cylindrical bodies (drums) or rubber tyres in which the operating facilities for travelling, steering, braking and vibrating are disposed in such a way that the intended operation of the machine has to be undertaken by an attending operator or by remote control in accordance with **[A1]** Annex A **[A1]**

3.1.3

towed roller

compaction machine with one or more metallic cylindrical bodies (drums) or rubber tyres which do not possess an independent drive system and where the operator's station is located at the towing unit

3.1.4

vibratory plate and vibratory rammer

compaction machine with mainly flat base plate which is transposed into vibration. It is operated by an attending operator or as an attachment to a carrier machine

EN 500-4:2006+A1:2009 (E)**3.1.5****explosion rammer**

compaction machine with mainly a flat pad as a compacting tool which moves in a predominantly vertical direction by explosion pressure. The machine is operated by an attending operator

3.2**braking system**

system affecting all machine components between the operator and the wheels and drums, which effects the machine stopping and holding (see Annex A for further definition)

4 List of significant hazards

Annex F of EN 500-1:2006 applies.

5 Safety requirements and/or protective measures**5.1 Lighting, signalling and marking lights and reflex-reflector devices**

5.2 of EN 500-1:2006 applies.

5.2 Operation and handling**5.2.1 Retrieval transportation and towing**

5.3.2 of EN 500-1:2006 applies.

5.2.2 Pedestrian-controlled rollers**5.2.2.1 General**

5.3.3 of EN 500-1:2006 applies with the following addition:

5.2.2.2 Handle bar

To prevent dangerous vertical swinging of the steering element (handle bar) of the single-drum pedestrian-controlled rollers, movement of the handle shall be not less than 0,2 m and not more than 1,4 m above the ground (see Figure 1).

iTeh STANDARD PREVIEW
(standards.iteh.ai)

[SIST EN 500-4:2007+A1:2009](https://standards.iteh.ai/catalog/standards/sist/a8509ef8-8bab-4d12-adad-c2f260b6d30b/sist-en-500-4-2007a1-2009)

<https://standards.iteh.ai/catalog/standards/sist/a8509ef8-8bab-4d12-adad-c2f260b6d30b/sist-en-500-4-2007a1-2009>

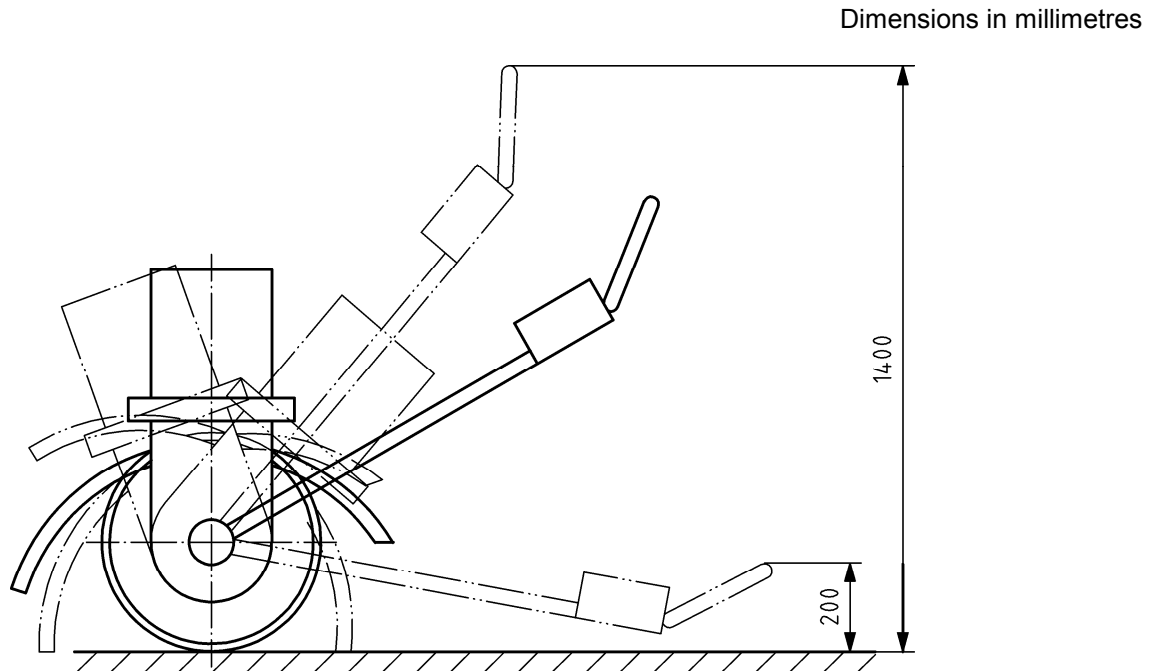

Figure 1 — Vertical swinging of single-drum walk-behind rollers

5.2.2.3 Protection device against crushing

Pedestrian-controlled rollers shall be provided with a protection device against crushing which is designed to prevent the operator from being trapped between the machine and an obstacle.

The device shall be so designed to stop the machine in a distance that is less than the total operating range of the device.

This device shall have an effective operating force not exceeding 230 N.

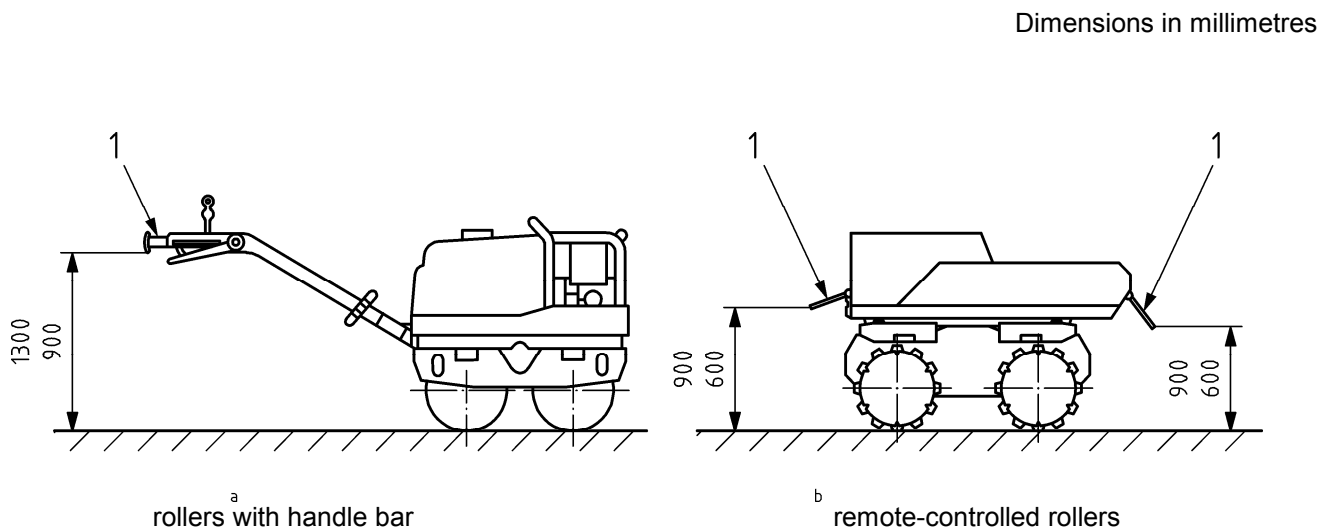

Key

1 stopping device

Figure 2 — Position of the safety device at pedestrian-controlled rollers

EN 500-4:2006+A1:2009 (E)**5.3 Operator's station**

5.4.1 of EN 500-1:2006 applies with the following addition:

- if the operator's position is offset from the space envelope width centreline, then the internal distance from the seat centreline to the side of the enclosure shall not be less than 295 mm.

5.4 Operator's seat

5.5 of EN 500-1:2006 applies.

5.5 Controls and indicators**5.5.1 General**

5.6 of EN 500-1:2006 applies with the following addition:

5.5.2 Travel control of pedestrian-controlled machines with handle bar

The machine-travel control of pedestrian-controlled rollers with an attended operator shall be of the hold-to-run type.

5.5.3 Controls for towed machines

For towed rollers, it shall be possible to control the on/off operate of the vibration from the operator's station on the towing unit.

5.5.4 Remote control of pedestrian-controlled rollers

5.5.4.1 Infrared remote control <https://standards.iteh.ai/catalog/standards/sist/a8509ef8-8bab-4d12-adad-c2f260b6d30b/sist-en-500-4-2007a1-2009>

Infrared remote-controlled pedestrian-controlled rollers shall conform to **Annex A**.

5.5.4.2 Cable remote control

The stretched cable length shall not be more than 4 m.

5.6 Starting

5.7.1 of EN 500-1:2006 applies with the following exception:

- the requirement for a neutral start function does not apply to vibratory plates and vibratory rammers if they are furnished with a centrifugal clutch in their driving system.

5.7 Stopping**5.7.1 General**

5.8 of EN 500-1:2006 applies with the following exceptions:

- hold-to-run control for forward and reverse function is not required for vibratory plates, vibratory rammers and explosion rammers;
- an emergency stop is not required for vibratory plates, vibratory rammers and explosion rammers.

5.7.2 Stopping device

Explosion rammers shall be fitted with a device to prevent the possibility of unintentional ignition after stopping.

An automatic stopping device is not required for vibratory plates and vibratory rammers equipped with a centrifugal force clutch.

5.7.3 Braking systems

5.7.3.1 Braking systems for rollers with ride-on operators

Rollers with ride-on operators shall be fitted with the following braking systems:

- a service brake system;
- a secondary brake system;
- a parking brake system.

A1 *deleted text* **A1**

The following applies for the service and secondary brake systems:

- the brake systems shall apply to all power-driven drums and wheels;
- in case of split drums, every drum part shall have the same brake torque;
- the brake systems of single-drum rollers and combined rollers shall apply to all wheels and to the drum;
- the service and the secondary brake shall work independently according to **A1** EN ISO 3450 **A1**.

If a hydrostatic drive is provided, it shall be interrupted when activating the secondary brake.

The performance of the braking systems shall meet the requirements of **A1** EN ISO 3450 **A1**.

All brake systems shall be controlled from the operator's station.

5.7.3.2 Braking systems for pedestrian-controlled rollers

ISO 17063 shall apply.

5.8 Access system to operator's station and to maintenance points

5.9 of EN 500-1:2006 applies with the following exception:

- on machines with articulated steering system and in the full articulated steering position, a minimum clearance of 150 mm shall be provided in the path of the access systems to the operator's station as illustrated in Figure 3.