

ISO

INTERNATIONAL ORGANIZATION FOR STANDARDIZATION

ISO RECOMMENDATION R 1919

AUTOMOBILES

SPARK PLUG M 14 × 1.25 WITH FLAT SEATING

1st EDITION

October 1970

COPYRIGHT RESERVED

The copyright of ISO Recommendations and ISO Standards belongs to ISO Member Bodies. Reproduction of these documents, in any country, may be authorized therefore only by the national standards organization of that country, being a member of ISO.

For each individual country the only valid standard is the national standard of that country.

Printed in Switzerland

Also issued in French and Russian. Copies to be obtained through the national standards organizations.

BRIEF HISTORY

The ISO Recommendation R 1919, *Automobiles – Spark plug M 14 × 1.25 with flat seating*, was drawn up by Technical Committee ISO/TC 22, *Automobiles*, the Secretariat of which is held by the Association Française de Normalisation (AFNOR).

Work on this question led to the adoption of Draft ISO Recommendation No. 1919, which was circulated to all the ISO Member Bodies for enquiry in October 1969. It was approved, subject to a few modifications of an editorial nature, by the following Member Bodies :

Belgium	Netherlands	Thailand
France	Portugal	Turkey
Germany	Romania	U.A.R.
Greece	South Africa, Rep. of	United Kingdom
Hungary	Spain	U.S.S.R.
Israel	Sweden	
Japan	Switzerland	

The following Member Body opposed the approval of the Draft :

U.S.A.

This Draft ISO Recommendation was then submitted by correspondence to the ISO Council, which decided to accept it as an ISO RECOMMENDATION.

iTeh STANDARD PREVIEW
(standards.iteh.ai)

ISO/R 1919:1970

<https://standards.iteh.ai/catalog/standards/sist/7c25cfc8-f0b3-4d48-80b5-595771c4cb2a/iso-r-1919-1970>

ISO Recommendation

R 1919

October 1970

AUTOMOBILES

SPARK PLUG M 14 × 1.25 WITH FLAT SEATING

1. SCOPE

This ISO Recommendation gives the essential dimensional characteristics of a type of spark plug used for engines with controlled ignition.

2. FIELD OF APPLICATION

The provisions of this ISO Recommendation only apply to spark plugs M 14 × 1.25 with flat seating with a normal or long reach.

3. REQUIRED CHARACTERISTICS AND THEIR TOLERANCES

3.1 Post terminal (see Fig. 2 and Annex)

The type preferred is the solid post terminal.

The threaded post terminal with nut is permitted (see Annex).

3.2 Dimensions and threading of the reach (see Fig. 1)

3.2.1 Dimensions of the reach

Dimensions in millimetres

Plug types	<i>A</i>	<i>B</i> max.	<i>Y</i>
Normal reach	12.7 ± 0.2	21	11.7 ± 0.3
Long reach	19.0 ± 0.2	27	18.0 ± 0.3

NOTES

- When the spark plugs have been tightened with a torque of 30 N.m (threads clean, smooth and dry), the gaskets must be 1.4 to 2.0 mm in thickness. If the gaskets are of a different thickness, a corresponding adjustment to dimensions *A*, *B* and *Y* should be made. Non-captive gaskets may be used in special cases.
- The dimension *A* may be increased for some types of plugs.

3.2.2 Thread

3.2.2.1 DIMENSION LIMITS

Dimensions in millimetres

		Plug thread (on finished plug) 6e	Tapped hole in cylinder head 6H
Major diameter	max.	13.937	not specified
	min.	13.725	14.000
Pitch diameter	max.	13.125	13.368
	min.	12.993	13.188
Minor diameter	max.	12.403	12.912
	min.	12.181	12.647

3.2.2.2 TOLERANCE GRADES

The tolerance grades of the thread M 14 × 1.25 of finished spark plugs and the corresponding tapped holes in the cylinder head are as follows :

- 6e for spark plugs;
- 6H for tapped holes in cylinder head.

NOTES

1. The threads M 14 × 1.25 of spark plugs and of the cylinder head holes correspond to ISO Recommendations
 - R 68, *ISO general purpose metric screw threads – Basic profile*;
 - R 261, *ISO general purpose metric screw threads – General plan*;
 - R 965/I and R 965/III, *ISO general purpose metric screw threads – Tolerances*.
2. The initial clearance $e = 0.063$ mm between the pitch diameters of the thread and the tapped hole is intended to prevent the possibility of seizure, as a result of combustion deposits on the bare threads, when removing the spark plugs.
This clearance is also intended to enable spark plugs with threads in accordance with this ISO Recommendation to be fitted in existing tapped holes.

3.3 Other dimensions of the spark plug

The other dimensions of the spark plug are indicated in Figures 1 and 2.

NOTE. – The diameter 12.2 ± 0.5 mm should be complied with between dimensions 29 and 33 mm.

Details not specified are left to the manufacturer's choice.

Dimensions in millimetres

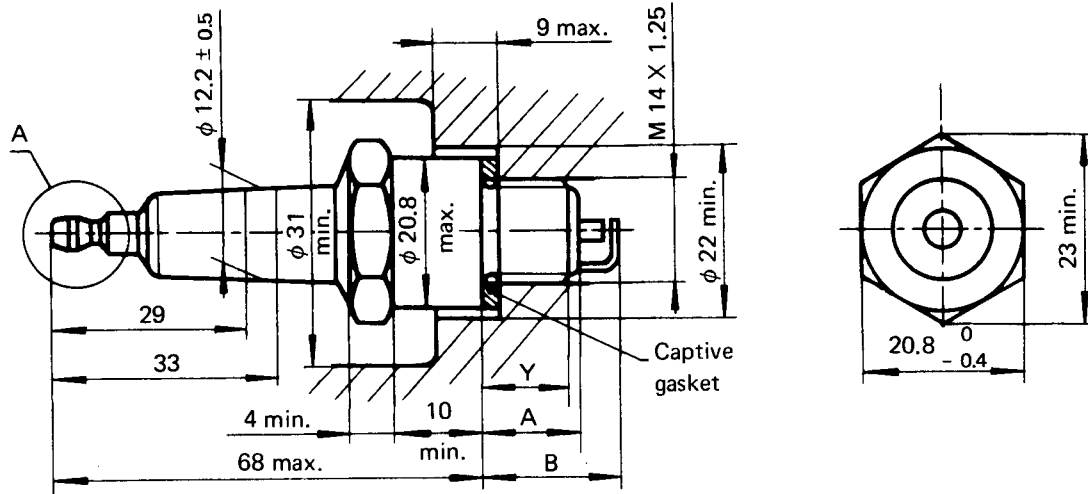

FIG. 1 - Spark plug M 14 x 1.25

Dimensions in millimetres

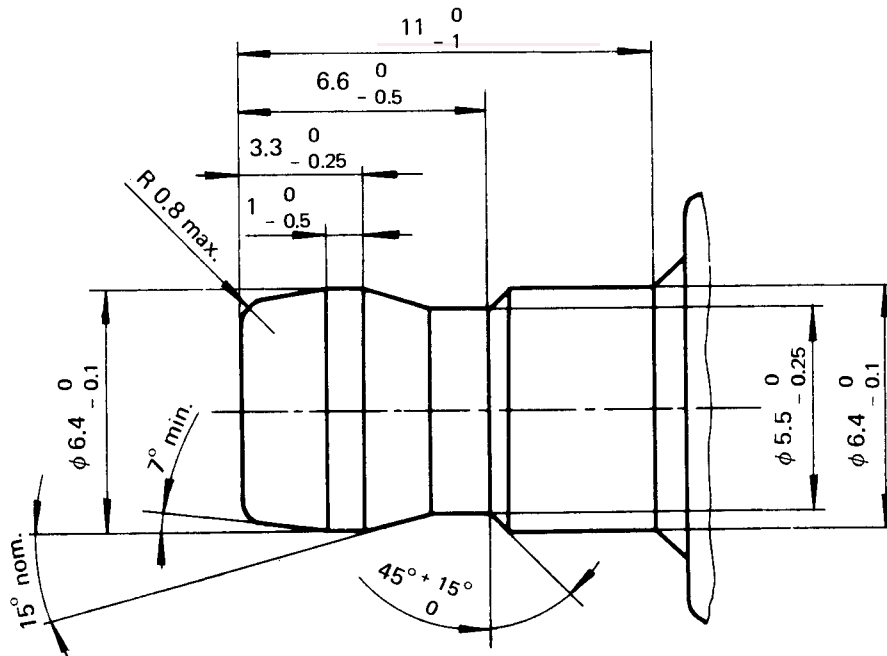

FIG. 2 - Solid post terminal (Detail A of Fig. 1)