



**SLOVENSKI STANDARD**  
**oSIST prEN 933-6:2011**  
**01-junij-2011**

---

**Preskusi geometričnih lastnosti agregatov - 6. del: Ocenjevanje značilnosti površine - Količnik sipkosti agregatov**

Tests for geometrical properties of aggregates - Part 6: Assessment of surface characteristics - Flow coefficient of aggregates

Prüfverfahren für geometrische Eigenschaften von Gesteinskörnungen - Teil 6: Beurteilung der Oberflächeneigenschaften - Fließkoeffizienten von Gesteinskörnungen

Essais pour déterminer les caractéristiques géométriques des granulats - Partie 6: Evaluation des caractéristiques de surface - Coefficient d'écoulement des granulats

**Ta slovenski standard je istoveten z: prEN 933-6 rev**

---

**ICS:**

91.100.15      Mineralni materiali in izdelki      Mineral materials and products

**oSIST prEN 933-6:2011**

**en,fr,de**



EUROPEAN STANDARD  
NORME EUROPÉENNE  
EUROPÄISCHE NORM

**DRAFT**  
**prEN 933-6 rev**

April 2011

ICS 91.100.15

Will supersede EN 933-6:2001

English Version

## Tests for geometrical properties of aggregates - Part 6: Assessment of surface characteristics - Flow coefficient of aggregates

Essais pour déterminer les caractéristiques géométriques  
des granulats - Partie 6: Evaluation des caractéristiques de  
surface - Coefficient d'écoulement des granulats

Prüfverfahren für geometrische Eigenschaften von  
Gesteinskörnungen - Teil 6: Beurteilung der  
Oberflächeneigenschaften - Fließkoeffizienten von  
Gesteinskörnungen

This draft European Standard is submitted to CEN members for enquiry. It has been drawn up by the Technical Committee CEN/TC 154.

If this draft becomes a European Standard, CEN members are bound to comply with the CEN/CENELEC Internal Regulations which stipulate the conditions for giving this European Standard the status of a national standard without any alteration.

This draft European Standard was established by CEN in three official versions (English, French, German). A version in any other language made by translation under the responsibility of a CEN member into its own language and notified to the CEN-CENELEC Management Centre has the same status as the official versions.

CEN members are the national standards bodies of Austria, Belgium, Bulgaria, Croatia, Cyprus, Czech Republic, Denmark, Estonia, Finland, France, Germany, Greece, Hungary, Iceland, Ireland, Italy, Latvia, Lithuania, Luxembourg, Malta, Netherlands, Norway, Poland, Portugal, Romania, Slovakia, Slovenia, Spain, Sweden, Switzerland and United Kingdom.

Recipients of this draft are invited to submit, with their comments, notification of any relevant patent rights of which they are aware and to provide supporting documentation.

**Warning** : This document is not a European Standard. It is distributed for review and comments. It is subject to change without notice and shall not be referred to as a European Standard.



EUROPEAN COMMITTEE FOR STANDARDIZATION  
COMITÉ EUROPÉEN DE NORMALISATION  
EUROPÄISCHES KOMITEE FÜR NORMUNG

**Management Centre: Avenue Marnix 17, B-1000 Brussels**

## Contents

Page

|   |    |
|---|----|
| Foreword .....  | 4  |
| 1 Scope.....  | 5  |
| 2 Normative references .....  | 5  |
| 3 Terms and definitions.....  | 5  |
| 4 Principle .....   | 6  |
| 5 Reference materials .....   | 6  |
| 5.1 Coarse aggregate material .....   | 6  |
| 5.2 Fine aggregate material.....  | 6  |
| 6 Apparatus .....   | 7  |
| 6.1 General.....  | 7  |
| 6.2 Apparatus for general purposes .....  | 7  |
| 6.3 Additional apparatus required for the determination of the flow coefficient of coarse aggregate ..... | 7  |
| 6.4 Additional apparatus required for the determination of the flow coefficient of fine aggregate .....   | 10 |
| 7 Determination of the flow coefficient of coarse aggregate .....   | 12 |
| 7.1 General.....  | 12 |
| 7.2 Preparation of test portions .....  | 12 |
| 7.2.1 Reference coarse aggregate.....   | 12 |
| 7.2.2 Test portions .....   | 12 |
| 7.3 Procedure .....   | 13 |
| 7.3.1 Common test procedure.....  | 13 |
| 7.3.2 Reference test .....  | 14 |
| 7.3.3 Material sample test.....   | 14 |
| 7.4 Calculation and expression of results .....   | 14 |
| 7.5 Test report .....   | 15 |
| 7.5.1 Required data .....   | 15 |
| 7.5.2 Optional data .....   | 15 |
| 8 Determination of the flow coefficient of fine aggregate.....  | 15 |
| 8.1 General.....  | 15 |
| 8.2 Preparation of test portions.....   | 15 |
| 8.2.1 Reference fine aggregate .....  | 15 |
| 8.2.2 Test portions .....   | 16 |
| 8.3 Procedure .....   | 16 |
| 8.3.1 Common test procedure.....  | 16 |
| 8.3.2 Reference test .....  | 16 |
| 8.3.3 Material sample test.....   | 17 |
| 8.4 Calculation and expression of results .....   | 17 |
| 8.5 Test report .....   | 17 |
| 8.5.1 Required data .....   | 17 |
| 8.5.2 Optional data .....   | 17 |
| Annex A (informative) Example of test data sheet – coarse aggregate.....                                  | 18 |
| Annex B (informative) Precision .....   | 19 |
| B.1 Coarse aggregate.....   | 19 |
| B.2 Fine aggregate.....   | 19 |
| Annex C (informative) Example of test data sheet – fine aggregate .....                                   | 20 |

**Bibliography** ..... 21

**iTeh STANDARD PREVIEW**  
**(standards.iteh.ai)**

SIST EN 933-6:2014

<https://standards.iteh.ai/catalog/standards/sist/0491381f-fff7-4e4b-9d7b-2301fbf3fe48/sist-en-933-6-2014>

## Foreword

This document (prEN 933-6:2011) has been prepared by Technical Committee CEN/TC 154 “Aggregates”, the secretariat of which is held by BSI.

This document is currently submitted to the CEN Enquiry.

This document will supersede EN 933-6:2001.

This European Standard forms part of a series of tests for geometrical properties of aggregates. Test methods for other properties of aggregates will be covered by parts of the following European Standards:

EN 932, *Tests for general properties of aggregates*

EN 1097, *Tests for mechanical and physical properties of aggregates*

EN 1367, *Tests for thermal and weathering properties of aggregates*

EN 1744, *Tests for chemical properties of aggregates*

EN 13179, *Tests for filler aggregate used in bituminous mixtures*

The other parts of EN 933 are:

Part 1: Determination of particle size distribution — Sieving method

Part 2: Determination of particle size distribution — Test sieves, nominal size of apertures

Part 3: Determination of particle shape — Flakiness index

Part 4: Determination of particle shape — Shape index

Part 5: Determination of percentage of crushed and broken surfaces in coarse aggregate particles

Part 7: Determination of shell content — Percentage of shells in coarse aggregates

Part 8: Assessment of fines — Sand equivalent test

Part 9: Assessment of fines — Methylene blue test

Part 10: Assessment of fines — Grading of fillers (air jet sieving)

Part 11: Classification test for the constituents of coarse recycled aggregate

Annexes A, B and C are informative.

This standard includes a Bibliography.

## 1 Scope

This European Standard describes the reference method used for type testing, and in case of dispute, for determining the flow coefficient of coarse and fine aggregates. For other purposes, in particular factory production control, other methods may be used provided that an appropriate working relationship with the reference method has been established. Examples of advanced test methods can be found in the Bibliography.

This European Standard applies to coarse aggregate of sizes between 4 mm and 20 mm and to fine aggregate of size up to 2 mm.

NOTE 1 For coarse aggregates between 4 mm and 20 mm, the flow coefficient is linked with the percentage of crushed or broken surfaces of an aggregate and can therefore be used in association with the method specified in EN 933-5. Shape and surface texture characteristics also influence the result.

NOTE 2 Experience of this test has been generally limited to natural aggregates.

## 2 Normative references

The following referenced documents are indispensable for the application of this document. For dated references, only the edition cited applies. For undated references, the latest edition of the referenced document (including any amendments) applies.

EN 932-2, *Tests for general properties of aggregates — Part 2: Methods for reducing laboratory samples.*

EN 932-5, *Tests for general properties of aggregates — Part 5: Common equipment and calibration.*

EN 933-2, *Tests for geometrical properties of aggregates — Part 2: Determination of particle size distribution — Test sieves, nominal size of apertures.*

EN 933-3, *Tests for geometrical properties of aggregates — Part 3: Determination of particle shape — Flakiness index.*

EN 1097-6, *Tests for mechanical and physical properties of aggregates — Part 6: Determination of particle density and water absorption.*

## 3 Terms and definitions

For the purposes of this European Standard the following terms and definitions apply.

### 3.1

#### **aggregate size**

designation of aggregate in terms of lower ( $d$ ) and upper ( $D$ ) sieve sizes expressed in terms as  $d/D$

NOTE This designation accepts the presence of some particles which will be retained on the upper sieve (oversize) and some which will pass the lower sieve (undersize).

### 3.2

#### **constant mass**

mass determined by successive weighings performed at least 1 h apart and not differing by more than 0,1 %

NOTE In many cases constant mass can be achieved after a test portion has been dried for a pre-determined period in a specified oven at  $(110 \pm 5) ^\circ\text{C}$ . Test laboratories can determine the time required to achieve constant mass for specific types and sizes of sample dependent upon the drying capacity of the oven used.

**prEN 933-6:2011 (E)****3.3****laboratory sample**

sample intended for laboratory testing

**3.4****particle size fraction,  $d_i/D_i$** 

fraction of an aggregate passing the larger ( $D_i$ ) of two sieves and retained on the smaller ( $d_i$ )

**3.5****test portion**

sample used as a whole in a single test

**4 Principle**

The flow coefficient of an aggregate is the time, expressed in seconds, for a specified volume of aggregate to flow through a given opening, under specified conditions using a standard apparatus.

**5 Reference materials****5.1 Coarse aggregate material**

A 6,3/10 mm reference aggregate with a flow time of  $(100 \pm 2)$  s when the shutter has an opening of  $(42,0 \pm 0,2)$  mm.

In the various calculations, the flow time  $E_R$  of this reference coarse aggregate shall be taken as equal to 100 s and its pre-dried particle density  $\rho_p$  shall be taken as equal to  $2,70 \text{ Mg/m}^3$ .

NOTE 1 At present the only recognized source of reference aggregate is the Laboratoire Régional des Ponts et Chaussées (LRPC), Rouen, BP 245, 76121 Le Grand-Quevilly, France. {Telephone: + (33) 2 35 68 81 00 – Fax: + (33) 2 35 68 88 60 – e-mail: lrpc-rouen.cete-nc@developpement-durable.gouv.fr}

NOTE 2 An alternative source of reference coarse aggregate can be used provided that the flow coefficient of that aggregate is established in a controlled experiment carried out in at least ten laboratories, by cross testing against the LRPC reference coarse aggregate. In this case, the flow time  $E_R$  and the pre-dried particle density  $\rho_p$  of this alternative reference coarse aggregate should be used. In case of dispute, the LRPC reference coarse aggregate should be used.

**5.2 Fine aggregate material**

A 0,063/2 mm reference aggregate with a flow time of  $(32 \pm 2)$  s.

In the various calculations, the flow time  $E_{RS}$  of this reference fine aggregate shall be taken as equal to 32 s and its pre-dried particle density shall be taken as equal to  $2,70 \text{ Mg/m}^3$ .

NOTE 1 At present the only recognized source of reference aggregate is the Laboratoire Régional des Ponts et Chaussées (LRPC), Rouen, BP 245, 76121 Le Grand-Quevilly, France. {Telephone: + (33) 2 35 68 81 00 - Fax: + (33) 2 35 68 88 60 – e-mail: lrpc-rouen.cete-nc@developpement-durable.gouv.fr }

NOTE 2 An alternative source of reference fine aggregate can be used provided that the flow coefficient of that aggregate is established in a controlled experiment carried out in at least ten laboratories, by cross testing against the LRPC reference fine aggregate. In this case, the flow time  $E_{RS}$  and the pre-dried particle density  $\rho_p$  of this alternative reference fine aggregate should be used. In case of dispute, the LRPC reference fine aggregate should be used.



## 6 Apparatus

### 6.1 General

All apparatus, unless otherwise stated, shall conform to the general requirements of EN 932-5.

### 6.2 Apparatus for general purposes

**6.2.1** *Test sieves*, conforming to EN 933-2, of the following aperture sizes:

0,063 mm, 2 mm, 4 mm, 6,3 mm, 8 mm, 10 mm, 14 mm and 20 mm.

**6.2.2** *Ventilated oven*, thermostatically controlled to maintain a temperature of  $(110 \pm 5)$  °C or equipment for drying the aggregate which does not cause any particle size breakdown.

**6.2.3** *Balance*, accurate to 0,1 % of the mass to be weighed.

**6.2.4** *Stopwatch or stopclock*, to read 0,1 s.

### 6.3 Additional apparatus required for the determination of the flow coefficient of coarse aggregate

**6.3.1** *Bar sieves*, conforming to EN 933-3, with apertures of 4 mm and 5 mm.

**6.3.2** *Container*, of volume approximately 10 l.

**6.3.3** *Vibratory table*, (Figure 1) comprising the following parts:

**6.3.3.1** *Bubble level*, incorporated in the upper platform of the table and capable of setting in a horizontal position.

**6.3.3.2** *Four rubber suspensions*, of Shore hardness  $(160 \pm 30)$  N/mm joining the upper platform of the table to the support frame.

**6.3.3.3** *Vibrator*, using unbalanced weights, fixed under the platform; with its axis of rotation horizontal and perpendicular to the axis of the flow channel. The speed of rotation shall be  $(2970 \pm 20)$  revolutions/min and the amplitude  $(0,18 \pm 0,02)$  mm when the flow unit is empty.

**6.3.3.4** *Baseplate*, of mass  $(100 \pm 10)$  kg, fixed under the frame.

Dimensions in millimetres

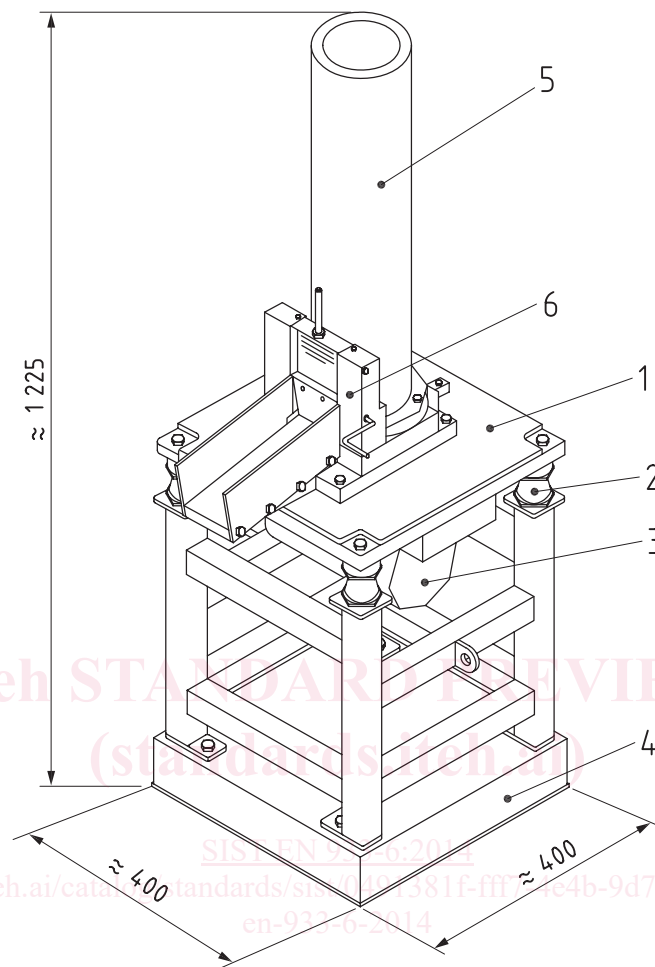
**Key**

- |   |                                 |   |  |
|---|---------------------------------|---|--|
| 1 | Vibratory platform              | 5 | Tube for test portion (see 6.3.4.1 and detail in Figure 2) |
| 2 | Rubber suspension (see 6.3.3.2) | 6 | Flow channel (see detail in Figure 2)                      |
| 3 | Vibrator (see 6.3.3.3)          |   |  |
| 4 | Baseplate (see 6.3.3.4)         |   |  |

**Figure 1 — Vibratory table and flow unit for coarse aggregate**

**6.3.4** *Flow unit*, of total mass  $(42,3 \pm 0,1)$  kg (Figure 2) comprising the following:

**6.3.4.1** *Plastic tube for test portion*, inside diameter  $(125 \pm 2)$  mm and height  $(610 \pm 10)$  mm.

**6.3.4.2** *Metal shutter*, to adjust the height of the opening between  $(40 \pm 1)$  mm and  $(60 \pm 1)$  mm.

NOTE The height of the opening can be checked by using metal gauge block of a given height  $\pm 0,1$  mm.

**6.3.4.3** *Metal movable flap*, to release the flow of material.

**6.3.4.4** *Metal flow channel*, with a slope of  $(10,0 \pm 0,5)^\circ$ , a width of  $(90 \pm 1)$  mm and fitted with plastic sides.

Dimensions in millimetres

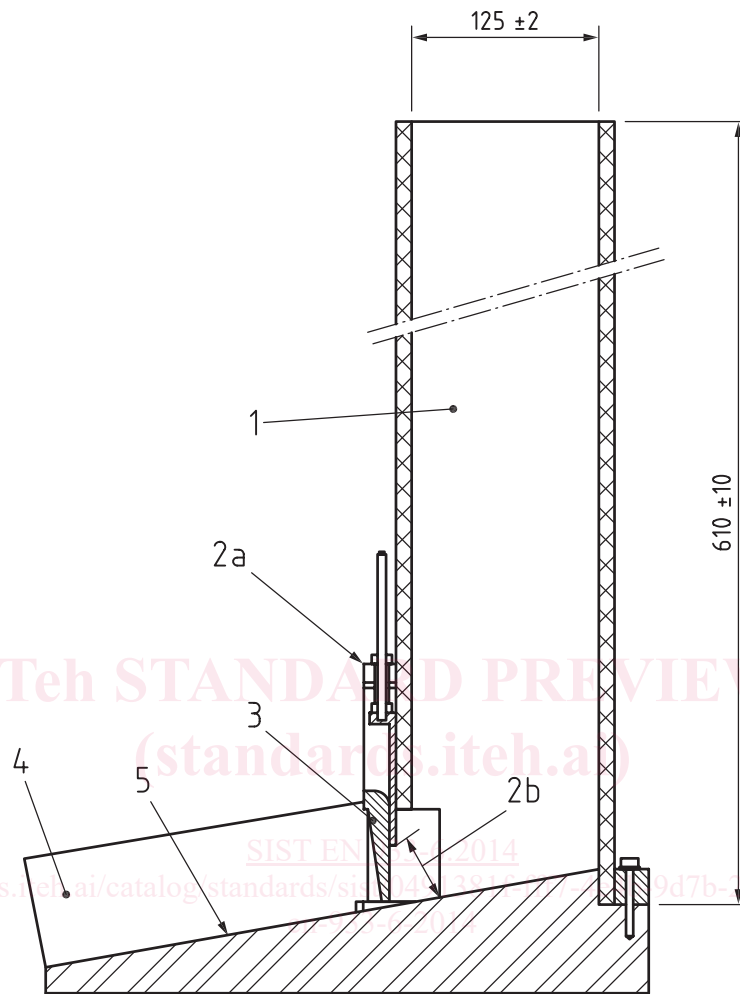
**Key**

- 1 Tube for test portion (see 6.3.4.1)
- 2a Shutter (see 6.3.4.2)
- 2b Opening adjustable between  $(40 \pm 1)$  mm and  $(60 \pm 1)$  mm
- 3 Movable flap (see 6.3.4.3)
- 4 Flow channel (see 6.3.4.4)
- 5 Slope  $10,0^\circ \pm 0,5^\circ$

**Figure 2 — Flow unit for coarse aggregate**