



Standard Specification for Fiberglass (GRP) Pultruded Open-Weather Storm and Guard, Square Railing Systems¹

This standard is issued under the fixed designation F1092; the number immediately following the designation indicates the year of original adoption or, in the case of revision, the year of last revision. A number in parentheses indicates the year of last reapproval. A superscript epsilon (ϵ) indicates an editorial change since the last revision or reapproval.

1. Scope

1.1 This specification provides the material requirements, construction, installation, and testing requirements for open-weather deck, storm-and-guard, fiberglass square railing systems. Components are to be manufactured by the pultrusion process.

1.2 The values stated in inch-pound units are to be regarded as the standard. The SI units given in parentheses are for information purposes only.

1.3 The following safety hazards caveat pertains only to the test methods portion, Section 9, of this specification: *This standard does not purport to address all of the safety concerns, if any, associated with its use. It is the responsibility of the user of this standard to establish appropriate safety and health practices and determine the applicability of regulatory limitations prior to use.*

2. Referenced Documents

2.1 ASTM Standards:²

- D570 Test Method for Water Absorption of Plastics
- D638 Test Method for Tensile Properties of Plastics
- D695 Test Method for Compressive Properties of Rigid Plastics
- D790 Test Methods for Flexural Properties of Unreinforced and Reinforced Plastics and Electrical Insulating Materials
- D792 Test Methods for Density and Specific Gravity (Relative Density) of Plastics by Displacement
- D3846 Test Method for In-Plane Shear Strength of Reinforced Plastics
- D3917 Specification for Dimensional Tolerance of Thermosetting Glass-Reinforced Plastic Pultruded Shapes

¹ This specification is under the jurisdiction of ASTM Committee F25 on Ships and Marine Technology and is the direct responsibility of Subcommittee F25.03 on Outfitting and Deck Machinery.

Current edition approved March 1, 2004. Published March 2004. Originally approved in 1987. Last previous edition approved in 1994 as F1092 – 87(1994) ^ε1. DOI: 10.1520/F1092-04.

² For referenced ASTM standards, visit the ASTM website, www.astm.org, or contact ASTM Customer Service at service@astm.org. For *Annual Book of ASTM Standards* volume information, refer to the standard's Document Summary page on the ASTM website.

E84 Test Method for Surface Burning Characteristics of Building Materials

3. Terminology Definition

3.1 *pultrusion*—process of pulling fiberglass rovings (strands), mats, and other forms of reinforcements such as woven fiberglass through baths of thermosetting liquid resin, and then through a heated forming die (made of steel) to form a completed composite fiberglass structural shape.

3.1.1 *Discussion*—The heated die causes a chemical reaction to be initiated in the resin. The liquid resin molecules will cross-link and develop into a hardened plastic that is reinforced with the fiberglass.

4. Classification

4.1 Handrails and stanchions shall be fiberglass pultruded square tube available in the following two types:

4.1.1 *Type 1F*—Three-course railing systems, for use along the exposed peripheries of freeboards, weather decks, and superstructure decks.

4.1.2 *Type 2F*—Two-course railing systems, for use on bridges, platforms, walkways, and elsewhere as needed.

5. Ordering Information

5.1 Orders for materials under this specification shall include the following information:

5.1.1 Quantity (lineal feet (metres) of railing system).

5.1.2 Name of material (fiberglass pultruded square railing system).

5.1.3 Type (See 4.1).

5.1.4 Fiberglass coaming, if specified (lineal feet (metres)). (See 6.2.5).

5.1.5 Attachment method for stanchions (see 6.2.6).

5.1.6 ASTM designation and year of issue.

6. Materials and Manufacture

6.1 Materials:

6.1.1 The fiberglass (GRP) pultruded square tube shall be 2 × 2 × ¼ in. (50 × 50 × 6.4 mm) with the outside corner radius ⅝ in. (4 mm). A synthetic surface veil shall be the outermost layer of reinforcement covering the entire exterior

surface. The resin used throughout the part shall be either a flame retardant isophthalic polyester or a flame retardant vinyl ester resin containing an ultra-violet radiation (UV) inhibitor. The fiberglass pultruded square tube shall achieve a flame spread index of 25 or less rating in accordance with Test Method E84. In addition, the fiberglass pultruded square tube shall achieve a smoke developed index of 450 or less. The exterior of the pultruded square tubing shall have a 1 mil (0.025 mm) minimum polyurethane protective coating for added ultraviolet protection. The fiberglass pultruded square tubing shall meet the properties specified in Table 1 and dimensional tolerances shall be in accordance with Specification D3917.

6.1.2 Fiberglass sheet or solid fiberglass bar shall be used to fabricate the internal connectors for the square tube. The internal connectors will be 1½ × 1½ in. (38.1 × 38.1 mm) with length and angularity variable to meet the requirements of each connection. Angular connections shall be fabricated from fiberglass sheet bonded together using a bisphenol A/epichlorohydrin epoxy resin with an amine curing agent to give a minimum thickness of 1½ in. (38.1 mm). The angular connections will be fabricated to the proper dimension from the fiberglass sheets that have been bonded together. Fiberglass sheet used for angular connections shall meet the properties specified in Table 1. Fiberglass solid bar, 1½ × 1½ in. (38.1 × 38.1 mm), shall be used for the straight connections and shall meet the properties specified in Table 1.

6.1.3 Rivets shall be nickel copper or nonmetallic.

6.1.4 Bolts shall be ½ in. (12.7 mm) diameter, 316 stainless steel.

6.1.5 Adhesive used to bond internal connectors to fiberglass pultruded square tube shall be a bisphenol A/epichlorohydrin epoxy resin with an amine curing agent.

6.2 *Manufacture:*

6.2.1 There shall be a minimum clearance of 4 in. (101 mm) between rail or stanchion centerline and other structure except where a direct tie-in is desired.

6.2.2 Stanchions and standoffs are to be spaced on 5 ft (1.52 m) maximum centers.

6.2.3 All top rails are to be located 42 in. (1.067 m) above the deck (deck to top of square tube).

6.2.4 Railing system height for ladders shall be measured vertically from the nosing line.

6.2.5 Coaming constructed of fiberglass pultruded material shall meet the properties specified in Table 1. Fiberglass coaming shall be 4 in. (101 mm) in vertical height from its top edge to the level of the deck. Fiberglass coaming shall be a corrugated or channel design with a minimum of ½ in. (12 mm) deep section or minimum ½ in. channel leg to develop added strength. It shall be securely fastened to the stanchion using nickel-copper rivets and with not more than ¼ in. (6.4 mm) clearance above floor level. The thickness shall be at least ⅜ in. (4.75 mm) with the overall depth not more than 1 in. (26 mm). See Fig. 1 for example.

6.2.6 Fiberglass square tube rail stanchions shall be attached to the deck or structural supports as follows:

6.2.6.1 Attached to steel coaming (Fig. 2).

6.2.6.2 Inserted in pedestal/stanchion mount (Fig. 3).

6.2.6.3 Attached to structural members (Fig. 4).

6.2.6.4 Attached to steel angle (Fig. 5).

TABLE 1 Fiberglass Pultruded Material Properties

	Test Method	psi (MPa)
<i>Specifications for 2 × ¼ (51 × 6.4) Pultruded Fiberglass Square Tube and Coaming:</i>		
Ultimate tensile strength in longitudinal direction	D638	30 000 (207), min
Ultimate compressive strength in longitudinal direction	D695	30 000 (207), min
Ultimate flexural strength in longitudinal direction	D790	30 000 (207), min
Ultimate shear strength in longitudinal direction	D3846	5500 (38), min
Ultimate tensile strength in transverse direction	D638	7000 (48), min
Ultimate compressive strength in transverse direction	D695	15 000 (103), min
Ultimate flexural strength in transverse direction	D790	10 000 (69), min
Ultimate shear strength in transverse direction	D3846	5500 (38), min
Density (lb/in. ³ /(kg/mm ³))	D792	0.065 (0.00180), min
Water absorption (24-h immersion)	D570	0.60 max, % by weight
<i>Specification for Pultruded Fiberglass Sheet:</i>		
Ultimate tensile strength in longitudinal direction	D638	20 000 (138), min
Ultimate compressive strength in longitudinal direction	D695	25 000 (172), min
Ultimate flexural strength in longitudinal direction	D790	30 000 (207), min
Ultimate shear strength in longitudinal direction	D3846	5500 (38), min
Ultimate tensile strength in transverse direction	D638	10 000 (69), min
Ultimate compressive strength in transverse direction	D695	15 000 (103), min
Ultimate flexural strength in transverse direction	D790	13 000 (90), min
Ultimate shear strength in transverse direction	D3846	5500 (38), min
Density (lb/in. ³ /(kg/mm ³))	D792	0.064 (0.00177), min
Water absorption (24-h immersion)	D570	0.50 max, % by weight
<i>Specifications for Pultruded 1½ × 1½ in. (38.1 × 38.1 mm) Solid Fiberglass Bar:</i>		
Ultimate tensile strength in longitudinal direction	D638	100 000 (689), min
Ultimate compressive strength in longitudinal direction	D695	60 000 (414), min
Ultimate flexural strength in longitudinal direction	D790	100 000 (689), min
Density (lb/in. ³ /(kg/mm ³))	D792	0.074 (0.00205), min
Water absorption (24-h immersion)	D570	0.25 max, % by weight

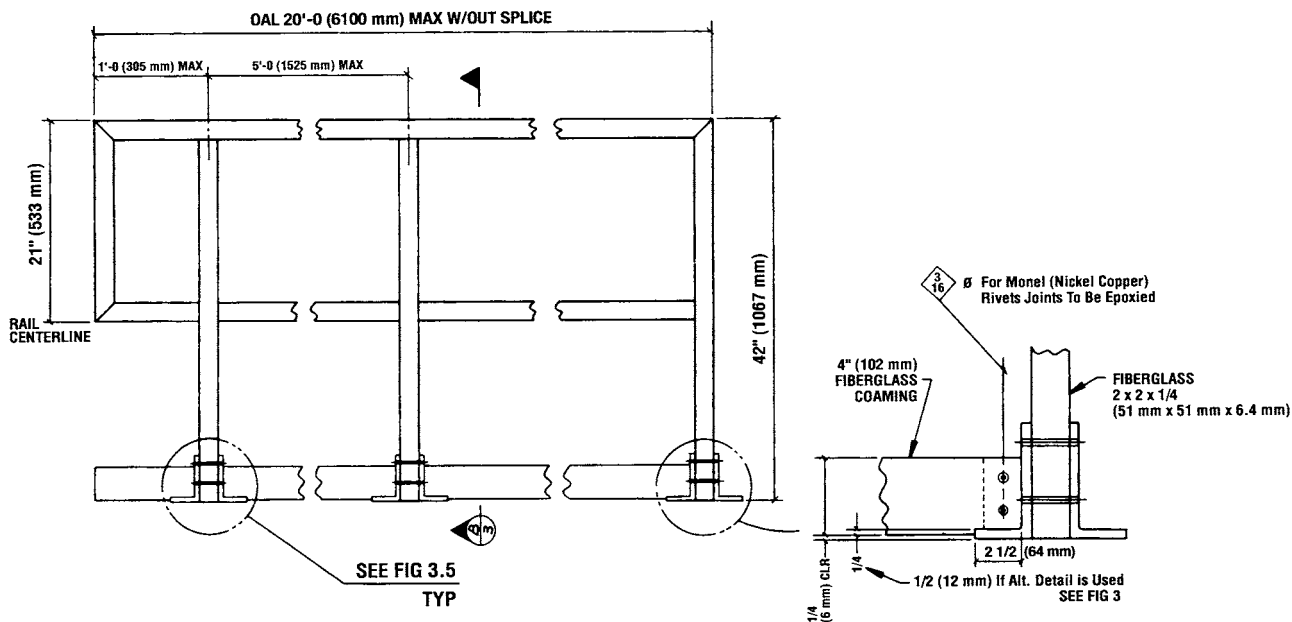

FIG. 1 Fiberglass Coaming

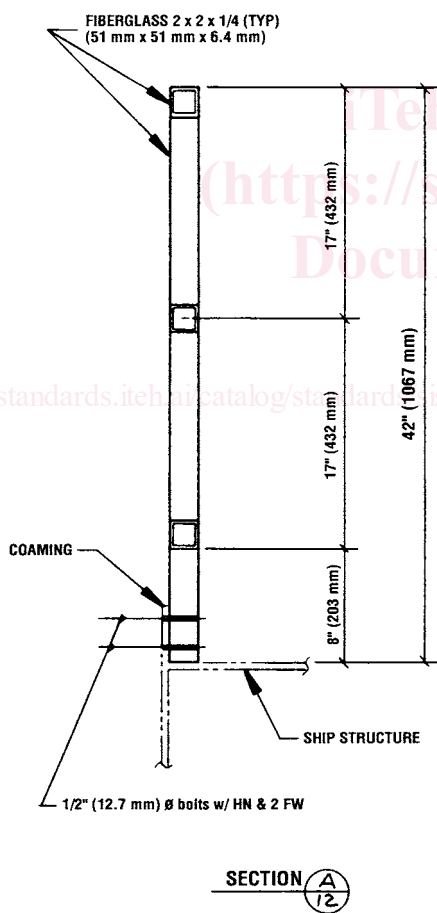

FIG. 2 Steel Coaming

7. Dimensions

7.1 Dimensions for Type 1F—Three-course rails shall be in accordance with Fig. 6.

7.2 Dimensions for Type 2F—Two-course rails shall be in accordance with Fig. 1.

8. Workmanship, Finish, and Appearance

8.1 All cut edges and holes shall be sealed with a compatible resin system containing a UV inhibitor.

8.2 All connections shall be made using a one piece solid internal connector (in accordance with 6.1.2) bonded to the interior of the square tube using an epoxy adhesive and riveted. The following types of connections are defined:

- 8.2.1 Corner connection (Fig. 7).
- 8.2.2 Splice (Fig. 8).
- 8.2.3 Midrail to stanchion (Fig. 9).
- 8.2.4 Top rail to stanchion (Fig. 10).
- 8.2.5 Stair railing system to stanchion (Fig. 11).
- 8.2.6 Stair rail to rail (Fig. 12).

8.3 All bolted connections shall have a one-piece solid internal connector (in accordance with 6.1.2) bonded to the interior of the square tube through which connector holes will be drilled. A minimum 1 in. (26 mm) length of the solid internal connector will be on each side of the drilled hole.

8.4 Additional solid internal connector pieces can be bonded with epoxy adhesive to the interior of the square tube as desired.

9. Test Methods

9.1 Test at least one end stanchion and one other stanchion of each platform or deck by application of a load horizontally in accordance with the methods in “Strength and Stiffness of Metal Railing Systems and Rails for Buildings.”³

³ “Strength and Stiffness of Metal Railing Systems and Rails for Buildings.” Journal of Testing and Evaluation, ASTM International, Vol 16, No. 2, March 1988, pp. 214-221.

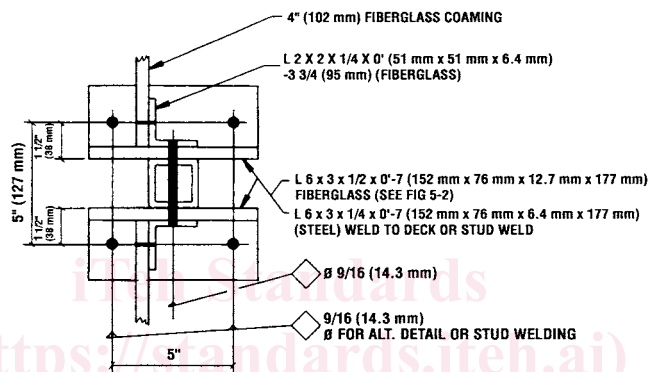
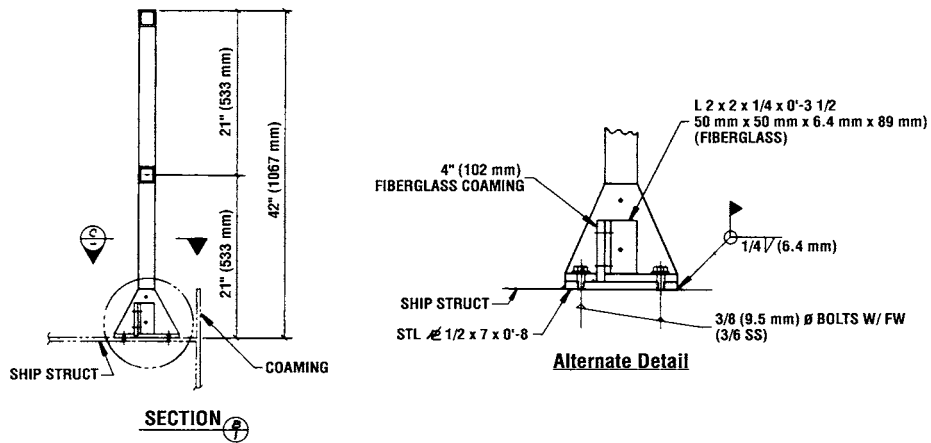

Welded to Steel Deck
 (Alternate—FRP Bolted to STL & Welded to Floor—SEE ALT DETAIL FIG 3)

NOTE 1—All joints to be epoxied and bolted or riveted.

FIG. 3 Pedestal/Stanchion Mount

<https://standards.iteh.ai/catalog/standards/sist/9d3b48fa-4f55-4246-b7dc-fa1e8c581951/astm-f1092-04>

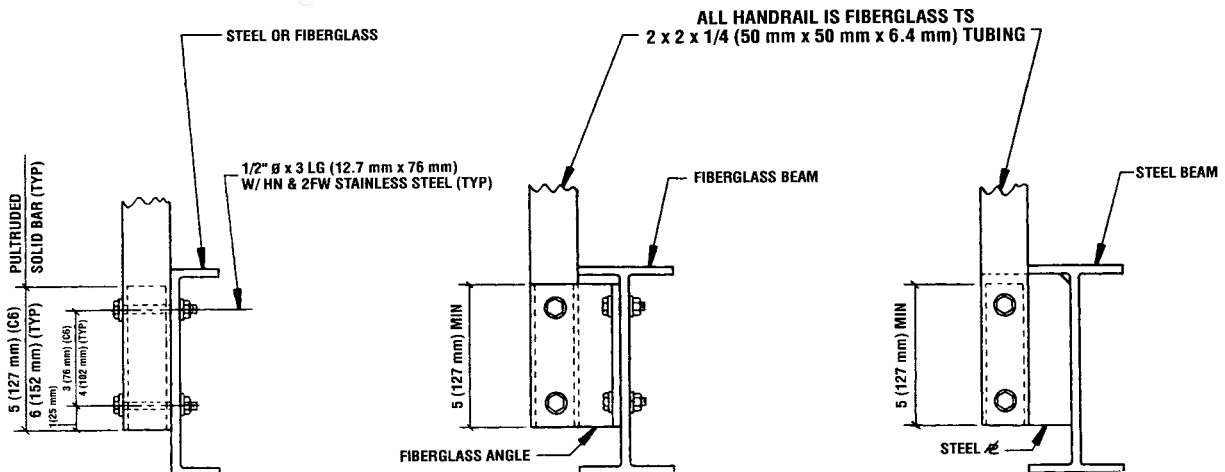

FIG. 4 Railing System Stanchions—Structural Members

10. Keywords

10.1 fiberglass rails; marine; open-weather deck; pultruded; railing system; ship; square rails; storm-and-guard