



Standard Test Method for Evaluating Carpet Embedded Dirt Removal Effectiveness of Residential Central Vacuum Cleaning Systems¹

This standard is issued under the fixed designation F 1284; the number immediately following the designation indicates the year of original adoption or, in the case of revision, the year of last revision. A number in parentheses indicates the year of last reapproval. A superscript epsilon (ϵ) indicates an editorial change since the last revision or reapproval.

1. Scope

1.1 This test method is applicable to residential central vacuum cleaning systems intended for cleaning carpets.

1.2 This test method applies only to embedded dirt removal from carpets.

1.3 *This standard does not purport to address all of the safety concerns, if any, associated with its use. It is the responsibility of the user of this standard to establish appropriate safety and health practices and determine the applicability of regulatory limitations prior to use.*

2. Referenced Documents

2.1 *ASTM Standards:*²

D 75 Practice for Sampling Aggregates

E 11 Specification for Wire Cloth and Sieves for Testing Purposes

F 608 Test Method for Evaluation of Carpet Embedded Dirt Removal Effectiveness of Household/Commercial Vacuum Cleaners

F 655 Specification for Test Carpets and Pads for Vacuum Cleaner Testing

F 922 Test Method for Motor Life Evaluation of an Electric Motorized Nozzle

F 1038 Test Method for Motor Life Evaluation of a Canister, Hand-held, Stick, and Utility Type Vacuum Cleaner Without a Driven Agitator

F 1334 Test Method for Determining A-Weighted Sound Power Level of Vacuum Cleaners

F 1409 Test Method for Straight Line Movement of Vacuum Cleaners While Cleaning Carpets

3. Terminology

3.1 *Definitions of Terms Specific to This Standard:*

3.1.1 *cleaning ability, n*—the potential of a vacuum cleaner to remove dirt from a surface (sometimes referred to in the industry as *cleanability, dry*).

3.1.2 *model, n*—the designation of a group of vacuum cleaners having identical, mechanical and electrical construction with only cosmetic or nonfunctional differences.

3.1.3 *population, n*—the total of all units of a particular model vacuum cleaner being tested.

3.1.4 *sample, n*—a group of vacuum cleaners taken from a large collection of vacuum cleaners of one particular model, which serves to provide information that may be used as a basis for making a decision concerning the larger collection.

3.1.5 *test run, n*—the definitive procedure that produces a singular measured result.

3.1.6 *test unit, n*—a single vacuum cleaner of the model being tested.

4. Significance and Use

4.1 This test method provides a laboratory test for determining the relative carpet dirt removal effectiveness of residential central vacuum cleaning systems when tested under standard conditions and on representative types of carpets.

4.2 This laboratory test method may not give a representation of carpet embedded dirt cleaning effectiveness in the home.

4.3 In order to provide a uniform basis for measuring performance as described in 1.1, standardized test carpets and a standardized test dirt are employed in this procedure.

¹ This test method is under the jurisdiction of ASTM Committee F11 on Vacuum Cleaners and is the direct responsibility of Subcommittee F11.21 on Cleanability.

Current edition approved March 1, 2004. Published March 2004. Originally approved in 1992. Last previous edition approved in 1999 as F 1284 – 99.

² For referenced ASTM standards, visit the ASTM website, www.astm.org, or contact ASTM Customer Service at service@astm.org. For *Annual Book of ASTM Standards* volume information, refer to the standard's Document Summary page on the ASTM website.

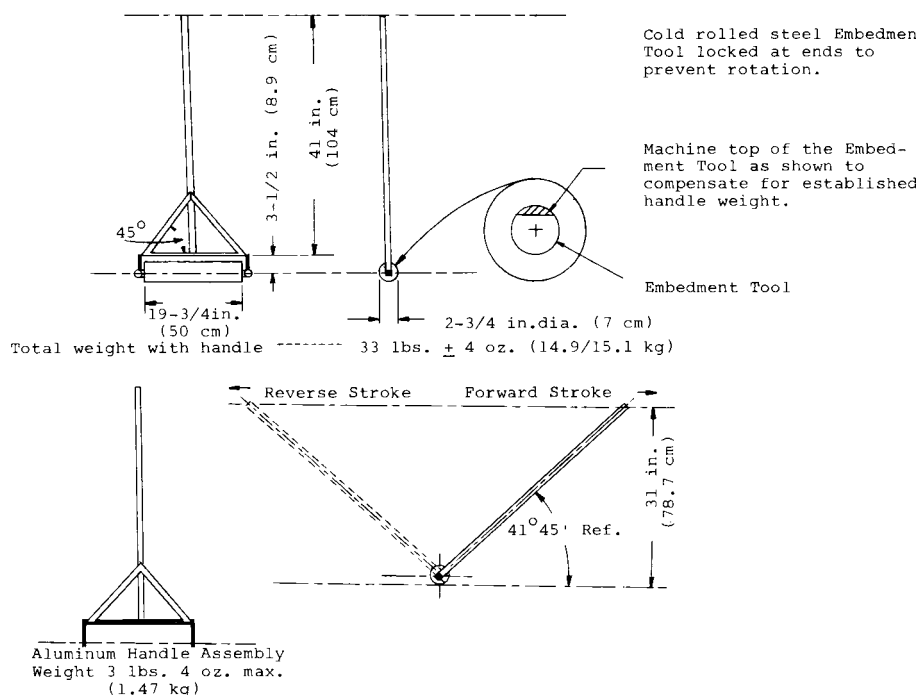

FIG. 1 Dirt Embedment Tool

4.4 The results reflect a non-loaded cleaning capability and may not be representative of cleaning capabilities under dirt loading conditions.

5. Apparatus

5.1 *Weighing Scale*³ (for weighing carpets; see 9.1.4 and 12.6)—The scale must be accurate to 0.035 oz (1 g) and have a weighing capacity of at least 15 lb (6.82 kg).

5.2 *Weighing Scale*⁴ (for weighing test dirt and non-disposable dirt receptacles; see 10.1.2 and 12.10)—The scale must be accurate to 0.0035 oz (0.10 g) and have a weighing capacity of at least 1.1 lb (500 g).

5.3 *Stopwatch* with a second hand, or other type of equipment capable of establishing the specified rate of movement and total cycle time.

5.4 *Voltmeter*, to measure input volts to the cleaning system to provide measurements accurate to within $\pm 1\%$.

5.5 *Voltage Regulator System*, to control the input voltage to the vacuum cleaner. The regulator shall be capable of maintaining the vacuum cleaner's rated voltage $\pm 1\%$ and rated frequency ± 1 Hz having a wave form that is essentially sinusoidal with 3 % max harmonic distortion for the duration of the test.

5.6 *Dirt Embedment Tool*, with the roller locked (see Fig. 1).

5.7 *Dirt Dispenser*—Dispensing system that provides the operator with a method to distribute the test dirt uniformly on the carpet test area.

5.8 *Carpet Conditioning Equipment*, to support the test carpet during new carpet conditioning and the removal of residual dirt from the test carpet before each test run (Fig. 2).

5.9 *Rotating Agitator Conditioning Vacuum Cleaner/Equipment*, for conditioning new test carpets and removing residual dirt from the test carpet before each test run. This cannot be the unit being tested.

NOTE 1—Automated methods for spreading the test dirt, embedding the test dirt, and cleaning and reconditioning the test carpets are acceptable if they do not change the results of this test method.

5.10 *Temperature and Humidity Indicators*, to provide temperature measurements accurate to within $\pm 1^\circ\text{F}$ ($\pm \frac{1}{2}^\circ\text{C}$) and humidity measurements accurate to within $\pm 2\%$ relative humidity.

5.11 *Supporting Surface*—A flat surface consisting of a piece of $\frac{3}{4}$ -in. (19-mm) thick exterior-grade plywood with the "A" surface upward to support the test carpet and pad. The test carpet and pad may be retained to the supporting surface, but only the four corners, by any acceptable means.

5.12 *Rotating Agitator Reference Vacuum Cleaner*, one, for calibrating test carpets (see 10.4).

5.13 *Straight-Air Canister Reference Vacuum Cleaner*, one, for calibrating test carpets (see 10.4).

5.14 *Orifice Adapter Tube*—See Fig. 3.

6. Materials

6.1 *Standard Carpets*, conforming to Specification F 655.

6.2 *Standard Carpet Padding*, conforming to Specification F 655.

6.3 *Test Dirt* (see Annex A1).

6.3.1 *Silica Sand*—(see Annex A1).

6.3.2 *Talc*—see (Annex A1).

³ The OHAUS Models GT-8000, LB30-CO and 1119D, all available from OHAUS, Inc. Florham Park, NJ, or the equivalent, have been found suitable for this purpose. It is recommended that the scale read directly in grams.

⁴ The Mettler-Toledo Model PM 2000, available from Mettler-Toledo, Inc., Box 71, Highstown, NJ, 08520. The OHAUS Model-GT-8000 available from OHAUS, Inc., Florham Park, NJ, or equivalent, have been found suitable for this purpose. It is recommended that the seal read directly in grams.

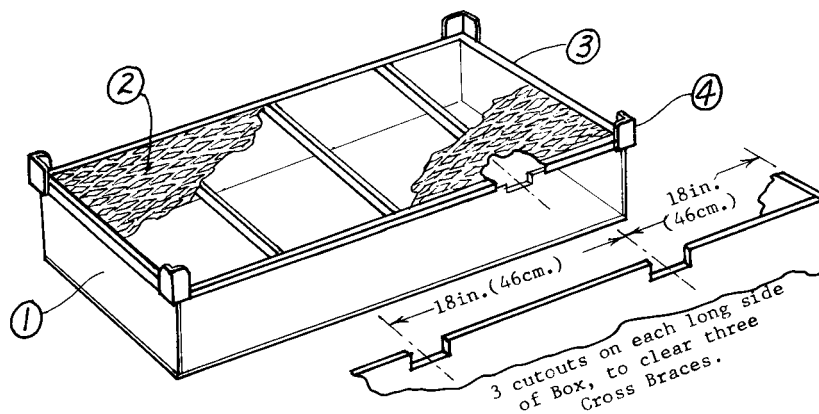

- ① -- Five Sided Box with open top.
 Outside Dimensions, Length -- 72 in. (183 cm.)
 Width -- 27 in. (69 cm.)
 Depth -- 12 in. (30.5 cm.)
 Material -- Plywood, 3/4 in. (1.9 cm.) thick.
 Optional -- Bottom of box may be sloped downward to center opening to simplify emptying of test dirt accumulation.
- ② -- Flattened Expanded Steel Top Panel, .070 in. (1.8 mm) thick, with "75% open" area, and with diamond shaped openings:--
 center-to-center, 2.1 in. (5.3 cm.) LWD
 center-to-center, 0.93 in. (2.4 cm.) SWD
 opening dimensions, 1.78 in. (4.5 cm.) LWD
 opening dimensions, 0.688 in. (1.7 cm.) SWD
 NOTE: Demcor Style "3/4 in.-#13" material has been found to be acceptable. (Designer's Metal Div'n. of Southern Electric, Inc.)

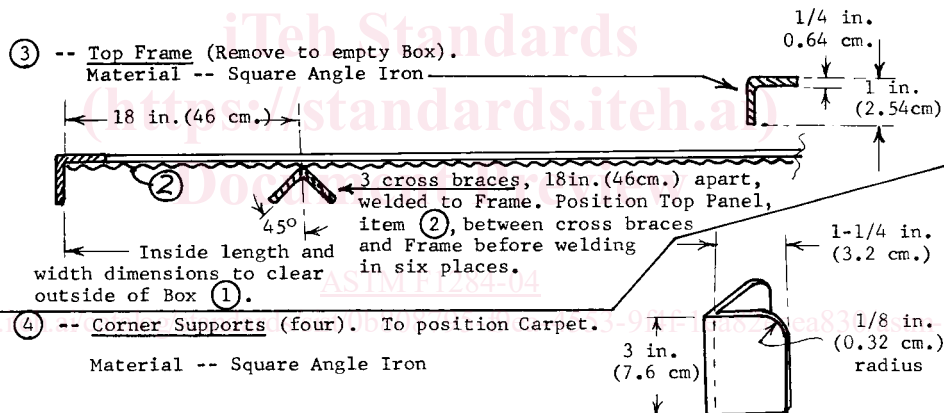

FIG. 2 Carpet Cleaning Rack

7. Sampling

7.1 A minimum of three units of the same model vacuum cleaner selected at random in accordance with good statistical practice shall constitute the population sample.

7.1.1 To determine the best estimate of the cleaning ability effectiveness for the population of the vacuum cleaner model being tested, the arithmetic mean of the cleaning ability rating of the sample from the population shall be established by testing it to a 90 % confidence level within ± 5 % of the mean value of the cleaning ability rating.

7.1.2 Annex A3 provides a procedural example for determining the 90 % confidence level and when the sample size shall be increased.

NOTE 2—See Annex A3 for method of determining 90 % confidence level.

8. Conditioning

8.1 Test Room—Maintain the test room in which all conditioning and vacuum cleaner testing is done at $70 \pm 5^\circ\text{F}$ ($21 \pm 3^\circ\text{C}$) and 45 to 55 % relative humidity.

8.2 All components involved in the test must remain and be exposed in the controlled environment for at least 16 h prior to the start of the test.

9. Test Carpets

9.1 New Test Carpets—New test carpets shall conform to Specification F 655.

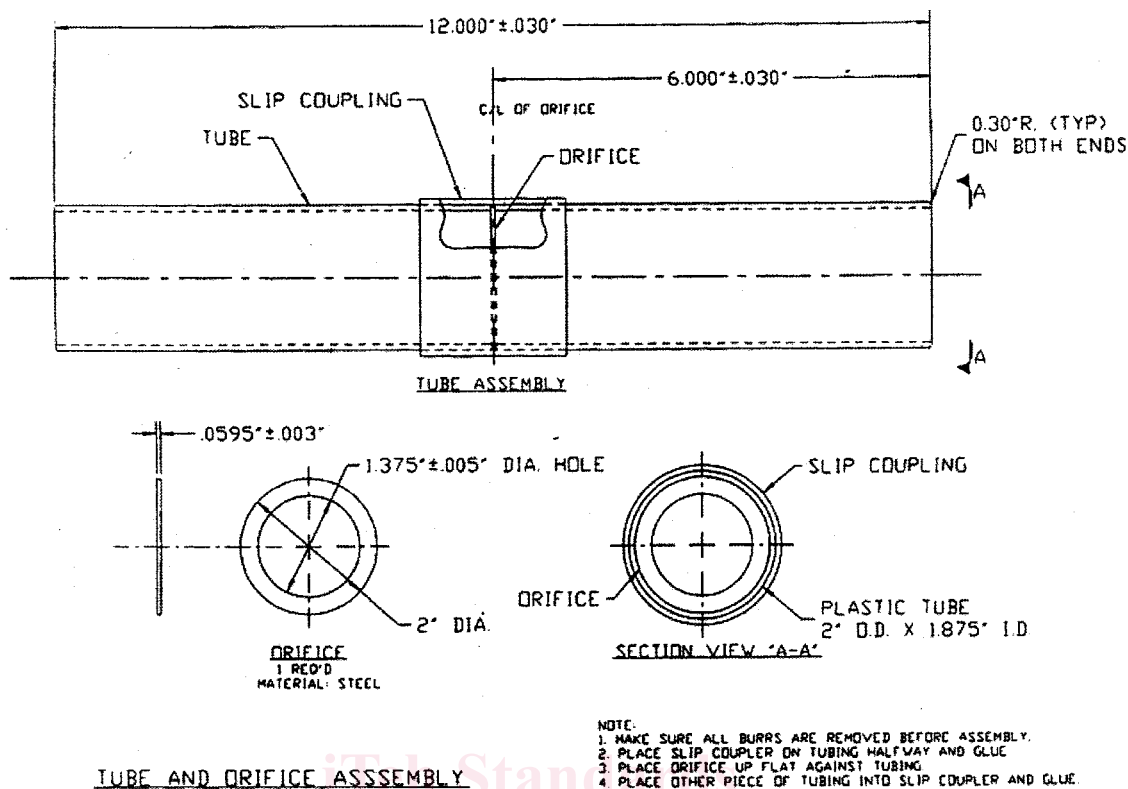

FIG. 3 Orifice Adapter Tube

9.1.1 Cut a sample of each test carpet to a size of 27 by 72 in. (690 by 1830 mm) minimum. If the warp direction or "lay" of the carpet fiber can be determined, it shall be in the 72-in. direction as indicated in Fig. 4. Carpets shall be bound on all sides.

9.1.2 Mark the test area on each carpet as indicated in Fig. 4.

9.1.3 Precondition new test carpet samples.

9.1.3.1 Precondition the entire area of the carpet by cleaning with the rotating agitator conditioning vacuum cleaner. Continue the operation until less than 2 g of carpet fiber is picked up in 5 min.

9.1.3.2 Run ten carpet-embedded dirt removal effectiveness test runs in accordance with Section 12 before conducting test calibrations as directed in Section 11.

9.1.4 Weigh and record the preconditioned weight of the carpet.

9.2 *Reconditioning Used Test Carpet Samples:*

9.2.1 To remove the residual dirt and stabilize the moisture content, clean the carpet with a rotating agitator conditioning vacuum cleaner until its weight does not exceed its previously measured, original preconditioned weight (9.1.4) by more than 2 g and less than 1 g is picked up by the conditioning vacuum cleaner after 4 minutes of cleaning.

9.2.2 *Procedure:*

9.2.2.1 Clean the test carpet with the rotating agitator conditioning vacuum cleaner at a rate of 1.8 ft/s (0.55 m/s) as follows:

9.2.2.2 Place the carpet on the carpet cleaning rack (Fig. 2) with pile side down. Run the rotating agitator conditioning vacuum cleaner over the carpet for 2 min. concentrating on the test area; then run the rotating agitator conditioning vacuum cleaner thoroughly over the entire area at least one time.

9.2.2.3 Then place the carpet (nap up) on the pad, on the plywood supporting surface and clean it with the rotating agitator conditioning vacuum cleaner for 2 minutes, concentrating on the test area; then run the rotating agitator vacuum cleaner thoroughly over the entire area at least one time.

9.2.2.4 Weigh the carpet.

9.2.2.5 Keep alternating 9.2.2.2 and 9.2.2.3, always ending with pile side up, until the carpet weight meets the requirements of 9.2.1.

9.2.2.6 A high-cleaning performance rotating agitator vacuum cleaner is recommended for reducing the time to recondition the test carpet.

9.2.2.7 Reconditioning equipment, which uses nondisposable filters should have the filter or filters cleaned after every four carpet reconditioning runs, or more often if desired.

9.2.2.8 Reconditioning equipment, which uses a primary disposable filter or primary filters should have the filter or filters replaced after every four carpet reconditioning runs, or more often, if required.

9.3 *Reconditioning Used Carpet Padding:*

9.3.1 Clean carpet padding by shaking after each day's testing, or more often if necessary, to remove any collected test dirt.

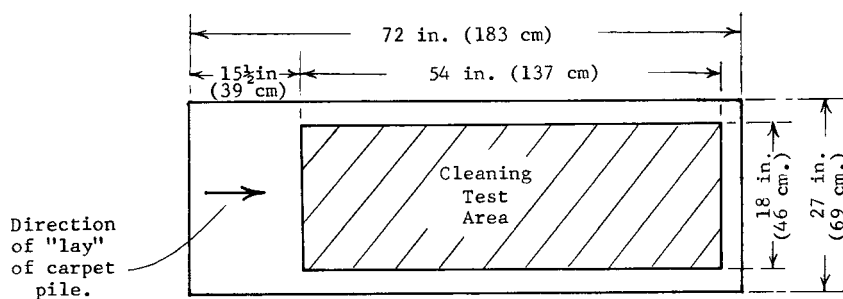

NOTE 1—Cleaning test area should be positioned as shown. First forward stroke of rotating agitator or carpet is in direction *with* lay of carpet.

FIG. 4 Test Carpet

9.3.2 Replace carpet padding when it has holes, tears, or other signs of wear.

10. Test Systems and Cleaning Tools

10.1 New Test Systems and Cleaning Tools:

10.1.1 *Preconditioning a New System*—Run the system in at rated voltage $\pm 1\%$ and rated frequency ± 1 Hz with filters in place for 1 h.

10.1.1.1 If a rotating agitator type cleaning tool is included with the system, operate it for 1 h with agitator bristles not engaged on any surface.

10.1.2 For systems with nondisposable filters, weigh and record the filter's original weight to the nearest 0.0035 oz (0.10 g). This may not be possible with some systems in which the nondisposable filter cannot be removed.

10.2 Used Test Systems and Cleaning Tools:

10.2.1 Recondition a *used* test system prior to each test run as follows:

10.2.1.1 Thoroughly remove excess dirt from the test system. Without using tools for disassembly, clean the entire outer surface, brushes, nozzle chamber, ductwork, inside of the chamber surrounding the primary filter, and inside hose and wands.

10.2.1.2 Clean the entire inner surface of the wands.

10.2.1.3 For systems using disposable filters, use a new primary filter for each test. Thoroughly clean the inside of the chamber surrounding the primary filter each time the filter is replaced.

10.2.1.4 For systems using cloth filter bags or other types of nondisposable dirt receptacles, empty according to manufacturer's instructions after each test run, and clean the cloth filter bag or nondisposable dirt receptacle until its weight is within 0.07 oz (2 g) of its original weight (see 10.1.2). Thoroughly clean the inside of the chamber surrounding the primary filter and reinstall the filter.

10.3 Test System and Tool Settings:

10.3.1 *Test System Settings*—If various settings are provided, set the motor speed setting, suction regulator, nozzle height, or combination thereof, using the manufacturer's specifications as provided in the instruction manual for each type of carpet. Contact the manufacturer if no instructions are given, or if the instructions are unclear or inadequate.

10.4 Reference Cleaners or Systems (Calibration):

10.4.1 Use the reference vacuum cleaners only for determining the reference rating of carpets and for the verification of carpet acceptability.

10.4.2 Maintain the performance of the reference vacuum cleaners throughout the carpet calibration period.

11. Test Carpet Calibration

11.1 The purpose of calibration is to determine when the carpet needs to be replaced by establishing a reference rating for each new preconditioned test carpet and to check this rating every 50 or fewer test runs.

11.2 The reference ratings are determined for each test carpet by the percent pickup using the reference rotating agitator vacuum cleaner or system and the reference straight air vacuum cleaner or system.

11.3 This percent pickup is determined by performing a cleaning effectiveness test (see Section 12).

11.4 Repeat the test carpet calibration procedure on the carpets every 50 or fewer test runs.

11.5 When the pickup for either reference vacuum cleaner or system varies by 4 g from the original reference rating for the carpet, replace the carpet.

12. Carpet-Embedded Dirt Removal Effectiveness Test

12.1 Set up the system as shown in Fig. 5. On the intake side, use an orifice tube adapter terminating with a wall inlet valve. Insert into the wall valve a flexible cleaning hose as provided with the system. The hose, wands, and nozzle should be those normally offered with the particular unit being tested. If more than one hose, wand, or nozzle type is offered with the unit, the manufacturer's part, catalog or model number of the ductwork, fittings, hose, wands, and nozzle used in the test must be recorded and presented as part of the cleaning effectiveness rating.

12.1.1 The hose should be laid out straight along the floor of the test area, except for the excess required to conveniently move the cleaning tool in the desired manner. This excess hose should be allowed to fall naturally at the tester's feet during actual stroking procedure. Allowance must be made for the foreshortening of the hose which might occur when suction is applied.

12.1.2 For those systems which include exhaust tubing and muffler, their use will be mandatory for testing.

NOTE 3—If necessary, the power unit may be positioned outside the test laboratory environment.

12.2 Prepare test carpets in accordance with 9.1 for new carpets or 9.2 for used carpets.

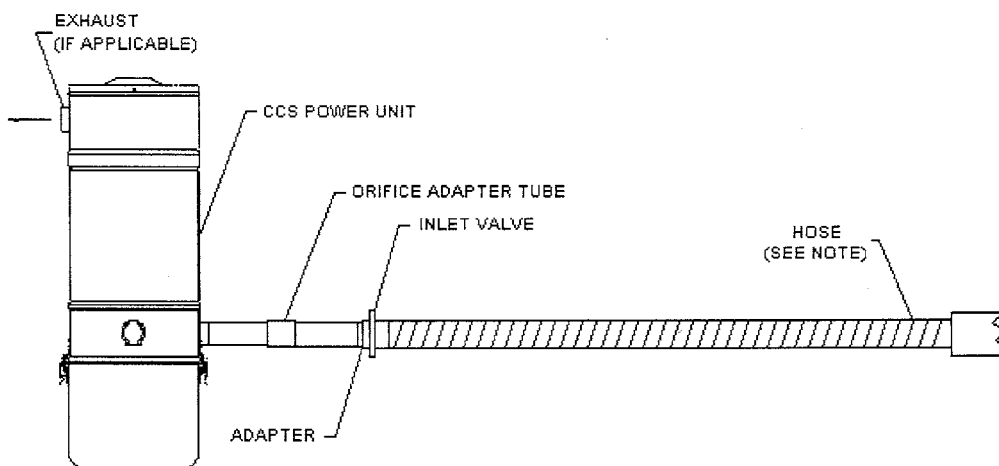

NOTE 1—Due to the height required for the tubing assembly, the assembly (in a plane) can be at any angle from vertical to parallel with the floor.
 NOTE 2— If flexible tubing is used for pipe sections, then flexible tubing must be supported in a straight line.
 NOTE 3—Hose is to be laid out in a straight line so as to minimize kinks or bends.

FIG. 5 Vacuum Cleaning System Test Set-Up

12.3 If preconditioning or reconditioning has been done more than 1 h before a test run, weigh the carpet. If the weight of the carpet exceeds the preconditioned or reconditioned weight by more than 2 g, clean the carpet with a rotating agitator conditioning vacuum cleaner until this criteria is met.

12.4 Perform the calibration test if required in accordance with Section 11.

12.5 Prepare test systems and dirt receptacles in accordance with Section 10.

12.5.1 For systems using paper filter bags, insert a new manufacturer's recommended bag.

12.5.2 Ensure the test system and cleaning tool settings have been made in accordance with Section 10.

12.6 Carefully weigh the test carpet immediately before placing it on the test platform. Record the weight to the nearest 0.035 oz (1.0 g).

12.7 Position the test carpet on the padding (with "scrim" side of the padding up) on the supporting surface (see 5.11).

12.8 Energize the vacuum cleaner for 2 min at nameplate rated voltage ($\pm 1\%$) and frequency (± 1 Hz) immediately preceding the test sequence of 12.13. For appliances with dual nameplate voltage ratings, conduct testing at the highest voltage.

12.8.1 For a rotating agitator-type cleaning tool, place it such that the bristles clear the supporting surface and no loose dirt is picked up.

12.8.2 For a straight air cleaning tool, operate with the rug tool unrestricted, positioned such that no loose dirt is picked up from the supporting surface.

12.9 *Test Dirt Preparation*—Weigh and mix 3.17 ± 0.0035 oz (90 ± 0.1 g) of silica sand and 0.35 ± 0.0035 oz (10 ± 0.1 g) of commercial grade talcum, both conforming to the specifications found in Annex A1.

12.9.1 Silica sand shall be sieved to assure conformance to the specification of Annex A1.2. Sieving shall be performed in accordance with Practice D 75.

12.9.2 Bulk mixing and storage of sieved constituents of silica sand is acceptable if assay analysis meets the specification of A1.2.

12.9.3 Bulk storage of test dirt mixture (sand plus talc) is not allowed.

12.10 Distribute 3.52 oz (100 g) of the test dirt *uniformly* on the cleaning test area (see Fig. 4), using any convenient spreading method.

12.11 Embed the test dirt into the carpet using the dirt embedment tool shown in Fig. 1. Perform the embedding process by using a dragging motion in both directions with the handle held at the angle shown. Drag the dirt embedment tool over the test area exactly 30 strokes, alternating directions forward and back. (A movement in one direction is one "stroke.") Use a uniform movement to provide a "stroke" time of 2.5 s (a rate of 1.8 ft/s (0.55 m/s)). The first forward stroke shall be in the direction of carpet lay.

12.11.1 An acceptable laboratory practice shall be used to ensure that (1) the dirt embedment tool shall not fall short of reaching the end boundaries of the test area, and (2) the tool shall cover both side boundaries of the test area at all times.

12.12 Clean embedment tool thoroughly.

12.13 Immediately following the 2-min "run-in" of 12.8, de-energize the vacuum cleaner, and place the vacuum cleaner nozzle on the test carpet so that the front edge of the vacuum cleaner nozzle lip coincides with the line defining the beginning of the test area and with the right side of the boundary of the 18-in. test width (see Fig. 5). The forward stroke of the nozzle shall be in the direction of the carpet lay (see Fig. 4).

12.13.1 Reasonable efforts shall be made to maintain the handle height at 31.5 in. during each test run for vacuum cleaner nozzles with a pivoting handle.

12.13.2 Reasonable efforts shall be made to maintain the vacuum cleaner's nozzle parallel to the test carpet surface during each test run for vacuum cleaners with nonpivoting handles.