

---

---

**Unplasticized poly(vinyl chloride)  
(PVC-U) pressure pipes — Determination  
of the fracture toughness properties**

*Tubes en poly(chlorure de vinyle) non plastifié (PVC-U) sous  
pression — Détermination de la ténacité*

**iTeh STANDARD PREVIEW**  
**(standards.iteh.ai)**

[ISO 11673:2005](https://standards.iteh.ai/catalog/standards/sist/782ce5dc-2b87-4629-94a5-a745e31973a4/iso-11673-2005)

[https://standards.iteh.ai/catalog/standards/sist/782ce5dc-2b87-4629-94a5-  
a745e31973a4/iso-11673-2005](https://standards.iteh.ai/catalog/standards/sist/782ce5dc-2b87-4629-94a5-a745e31973a4/iso-11673-2005)



**PDF disclaimer**

This PDF file may contain embedded typefaces. In accordance with Adobe's licensing policy, this file may be printed or viewed but shall not be edited unless the typefaces which are embedded are licensed to and installed on the computer performing the editing. In downloading this file, parties accept therein the responsibility of not infringing Adobe's licensing policy. The ISO Central Secretariat accepts no liability in this area.

Adobe is a trademark of Adobe Systems Incorporated.

Details of the software products used to create this PDF file can be found in the General Info relative to the file; the PDF-creation parameters were optimized for printing. Every care has been taken to ensure that the file is suitable for use by ISO member bodies. In the unlikely event that a problem relating to it is found, please inform the Central Secretariat at the address given below.

**iTeh STANDARD PREVIEW**  
**(standards.iteh.ai)**

[ISO 11673:2005](https://standards.iteh.ai/catalog/standards/sist/782ce5dc-2b87-4629-94a5-a745e31973a4/iso-11673-2005)

<https://standards.iteh.ai/catalog/standards/sist/782ce5dc-2b87-4629-94a5-a745e31973a4/iso-11673-2005>

© ISO 2005

All rights reserved. Unless otherwise specified, no part of this publication may be reproduced or utilized in any form or by any means, electronic or mechanical, including photocopying and microfilm, without permission in writing from either ISO at the address below or ISO's member body in the country of the requester.

ISO copyright office  
Case postale 56 • CH-1211 Geneva 20  
Tel. + 41 22 749 01 11  
Fax + 41 22 749 09 47  
E-mail [copyright@iso.org](mailto:copyright@iso.org)  
Web [www.iso.org](http://www.iso.org)

Published in Switzerland

# Contents

Page

Foreword .....	iv
Introduction .....	v
1 Scope .....	1
2 Normative references .....	1
3 Terms and definitions .....	1
4 Symbols .....	2
5 Principle .....	3
6 Preliminary test for response to immersion in dichloromethane .....	3
6.1 Reagents .....	3
6.2 Apparatus .....	3
6.3 Test specimen .....	3
6.4 Procedure .....	4
6.5 Assessment of results .....	4
7 Determination of fracture toughness .....	4
7.1 Apparatus .....	4
7.2 Preparation of test piece .....	6
7.3 Conditioning .....	7
7.4 Procedure .....	7
8 Expression of results .....	9
9 Test report .....	9
Annex A (normative) Mathematical calculations .....	10
Annex B (informative) Further guidance .....	12
Annex C (normative) Determination of yield strength .....	13
Bibliography .....	14

## Foreword

ISO (the International Organization for Standardization) is a worldwide federation of national standards bodies (ISO member bodies). The work of preparing International Standards is normally carried out through ISO technical committees. Each member body interested in a subject for which a technical committee has been established has the right to be represented on that committee. International organizations, governmental and non-governmental, in liaison with ISO, also take part in the work. ISO collaborates closely with the International Electrotechnical Commission (IEC) on all matters of electrotechnical standardization.

International Standards are drafted in accordance with the rules given in the ISO/IEC Directives, Part 2.

The main task of technical committees is to prepare International Standards. Draft International Standards adopted by the technical committees are circulated to the member bodies for voting. Publication as an International Standard requires approval by at least 75 % of the member bodies casting a vote.

Attention is drawn to the possibility that some of the elements of this document may be the subject of patent rights. ISO shall not be held responsible for identifying any or all such patent rights.

ISO 11673 was prepared by Technical Committee ISO/TC 138, *Plastics pipes, fittings and valves for the transport of fluids*, Subcommittee SC 5, *General properties of pipes, fittings and valves of plastics materials and their accessories — Test methods and basic specifications*.

ITEH STANDARD PREVIEW  
(standards.iteh.ai)

[ISO 11673:2005](https://standards.iteh.ai/catalog/standards/sist/782ce5dc-2b87-4629-94a5-a745e31973a4/iso-11673-2005)

<https://standards.iteh.ai/catalog/standards/sist/782ce5dc-2b87-4629-94a5-a745e31973a4/iso-11673-2005>

## Introduction

Studies have been undertaken at the international level to determine a method of measuring the characteristics of unplasticized poly(vinyl chloride) (PVC-U) which influence the ability of the pipe to withstand brittle failure emanating from minor flaws in the pipe matrix.

These studies have demonstrated that a test which measures fracture toughness characteristics of the material fulfils these requirements.

The method involves immersing a prepared test piece in dichloromethane to identify the point around the circumference of the pipe where the gelation is at a minimum level. The fracture toughness of the pipe is likely to be at its minimum value at this section.

The fracture toughness of the pipe is then obtained by subjecting a pre-notched C-ring test piece to a flexural stress across a notch, which has been introduced at the point where the fracture toughness value is likely to be at its lowest value (as determined by the dichloromethane immersion test).

It is intended that individual product standards will specify the requirement for the fracture toughness test.

NOTE Dichloromethane is now the accepted term for what was commonly referred to as methylene chloride.

**iTeh STANDARD PREVIEW**  
**(standards.iteh.ai)**

[ISO 11673:2005](https://standards.iteh.ai/catalog/standards/sist/782ce5dc-2b87-4629-94a5-a745e31973a4/iso-11673-2005)

<https://standards.iteh.ai/catalog/standards/sist/782ce5dc-2b87-4629-94a5-a745e31973a4/iso-11673-2005>

**iTeh STANDARD PREVIEW**  
**(standards.iteh.ai)**

ISO 11673:2005

<https://standards.iteh.ai/catalog/standards/sist/782ce5dc-2b87-4629-94a5-a745e31973a4/iso-11673-2005>

# Unplasticized poly(vinyl chloride) (PVC-U) pressure pipes — Determination of the fracture toughness properties

## 1 Scope

This International Standard specifies a method for determining the minimum fracture toughness, after a specified loading time, of unplasticized poly(vinyl chloride) (PVC-U) pressure pipes. It also makes provision for measuring alternative levels of fracture toughness.

## 2 Normative references

The following referenced documents are indispensable for the application of this document. For dated references, only the edition cited applies. For undated references, the latest edition of the referenced document (including any amendments) applies.

ISO 6259-2, *Thermoplastics pipes — Determination of tensile properties — Part 2: Pipes made of unplasticized poly(vinyl chloride) (PVC-U), chlorinated poly(vinyl chloride) (PVC-C) and high-impact poly(vinyl chloride) (PVC-HI)*

ISO 9852, *Unplasticized poly(vinyl chloride) (PVC-U) pipes — Dichloromethane resistance at specified temperature (DCMT) — Test method*

<https://standards.iteh.ai/catalog/standards/sist/782ce5dc-2b87-4629-94a5-a745e31973a4/iso-11673-2005>

## 3 Terms and definitions

For the purposes of this document, the following terms and definitions apply.

### 3.1

#### pipe wall thickness

$e$

value of the measurement of the wall thickness at any point around the circumference of the pipe, rounded up to the nearest 0,05 mm, expressed in millimetres

### 3.2

#### pipe wall thickness at the reference point

$e_{\text{ref}}$

value of the measurement of the wall thickness at the reference point on the pipe circumference where the notch is cut

### 3.3

#### C-ring

ring, as test piece, cut from the test specimen such that the cut surfaces are perpendicular to the longitudinal axis of the pipe

**3.4**  
**yield stress**

$\sigma$   
tensile stress at yield, expressed in megapascals<sup>1)</sup>

**3.5**  
**stress intensity factor**

$K$   
product of the yield stress,  $\sigma$ , perpendicular to the crack, a geometrical correction factor,  $y$ , and the square root of the notch depth,  $a$

NOTE 1 See Annex A.

NOTE 2 The term *factor* is used because it is common usage, even though the value has dimensions.

**3.6**  
**critical stress intensity factor**

$K_C$   
value of the stress intensity factor at the critical condition of crack propagation where  $K = K_C$

**3.7**  
**plain strain fracture toughness**

$K_{IC}$   
value of the stress intensity factor when the crack under load actually starts to enlarge under a plane-strain loading condition around the crack tip

NOTE If the specimen dimensions satisfy the validity criteria for plane-strain fracture toughness, then  $K_C = K_{IC}$ .  $K_{IC}$  is a material property.

iTeh STANDARD PREVIEW  
(standards.iteh.ai)

**3.8**  
**reference line**

line drawn along the axis of the pipe sample to mark the point at which the notch is to be cut

ISO 11673:2005

<https://standards.iteh.ai/catalog/standards/sist/782ce5dc-2b87-4629-94a5-a745e31973a4/iso-11673-2005>

NOTE This will be either the point of greatest attack following the dichloromethane test or, if attack is even all the way round, the point of the thinnest wall section.

**4 Symbols**

- $a$  crack length (notch depth) in millimetres;
- $d_m$  moment arm;
- $e$  pipe wall thickness in millimetres;
- $e_{ref}$  measured wall thickness, in millimetres, at the reference point on the pipe circumference where the notch is cut;
- $F_e$  wall thickness factor;
- $F_r$  ring geometric factor;
- $m$  test mass;
- $m_c$  C-ring mass;

---

1) 1 MPa = 1 N/mm<sup>2</sup>.



$m_L$	support clamp mass;
$\sigma_c$	fracture stress;
$\sigma_{pc}$	plastic collapse stress under plane stress conditions;
$\sigma_y$	uniaxial yield stress.

## 5 Principle

On the basis of the prior response of a test piece to immersion in dichloromethane, a C-ring section from a pipe is notched on its internal face at the region of maximum attack by dichloromethane. The notched sample is then subjected to a sustained flexural stress for a specified test period.

## 6 Preliminary test for response to immersion in dichloromethane

### 6.1 Reagents

#### 6.1.1 Dichloromethane, analytical grade

**WARNING** — The boiling temperature of dichloromethane is low (40 °C) and consequently has a high vapour pressure at ambient temperature. Furthermore, it can be toxic to skin and eyes. It is therefore necessary to take precautions when handling dichloromethane or test pieces, which have been immersed in it. The vapours are also toxic; the threshold limit value (TLV) comparable to the maximum admissible concentration (MAC) being 100 ml/m<sup>3</sup> (ppm). Ventilation of the room or the area in which the container is placed and where the test pieces are dried is, therefore, essential.

The consistency of colour and purity of the dichloromethane should be checked regularly, for example by measuring the refractive index. Whenever the refractive index differs by  $\pm 0,002$  from the original value, the dichloromethane should be changed. Any alternative checking procedure which gives the same result is acceptable.

**NOTE** Dichloromethane, technical grade, contains small quantities (1 % maximum each) of chloromethane (CHCl), of trichloromethane (CHCl<sub>3</sub>) and tetrachloromethane (CCl<sub>4</sub>). It has been noted that even if the level of these impurities were to attain 5 % in total, the results would not be significantly different.

### 6.2 Apparatus

**6.2.1 Cutting equipment**, capable of cutting an external chamfer on the test piece such that the chamfer penetrates at least 90 % of the wall thickness of the test piece with a minimum length of 10 mm when it is cut at an angle inclined to the longitudinal pipe axis.

**6.2.2 Covered tank**, resistant to dichloromethane, e.g. of glass, stainless steel.

**6.2.3 Thermostatic control equipment**, capable of maintaining the temperature of the dichloromethane at either (15  $\pm$  2) °C or (20  $\pm$  2) °C.

### 6.3 Test specimen

**6.3.1** The test specimen for both the dichloromethane test and fracture toughness test shall be a pipe of length not less than 200 mm.

**6.3.2** A reference line shall be drawn along the complete length of the test specimen, and marked with arrowheads to indicate the extrusion direction in such a way that the pipe is not scored. An arrowhead in the same direction shall be marked on the C-ring test piece (see 6.3.3 and 6.3.4).

**6.3.3** A ring of width  $(30 \pm 3)$  mm shall be cut from the test specimen in such a manner that the cut surfaces are perpendicular to the longitudinal axis of the pipe. This C-ring is retained for the fracture toughness test in accordance with Clause 7.

**6.3.4** The remainder of the test specimen is used for testing for the effect of dichloromethane. This shall be carried out in accordance with ISO 9852.

Where the tank is not big enough to take a large diameter pipe, it is permissible to cut the test piece longitudinally into sections, provided that the resultant sections can be related to the reference line.

## 6.4 Procedure

**6.4.1** Place the chamfered end(s) of the test piece in dichloromethane such that the chamfer is completely submerged at  $(15 \pm 2)$  °C for a period of  $(30 \pm 1)$  min or submerged at  $(20 \pm 2)$  °C for a period of  $(15 \pm 1)$  min.

**6.4.2** Remove the test piece to a well-ventilated area, e.g. a fume cupboard, until the dichloromethane has evaporated from its surface.

## 6.5 Assessment of results

**6.5.1** For the purpose of the dichloromethane test, the attack is classified by the extent of the lightening of the chamfered surfaces. There are three types of attack, classified as follows.

- Type 1: no apparent lightening of the surface under consideration.
- Type 2: overall uniform lightening of the surface under consideration.
- Type 3: non-uniform lightening of the surface under consideration. The area where the attack is greatest or the lightening is most dense shall be identified.

NOTE Lightening of the chamfer surfaces can be difficult to discern in pale coloured or white pipe specimens. In such cases, the observation of surface roughening can serve to indicate the extent of attack by dichloromethane.

**6.5.2** After carrying out an assessment as described in 6.5.1, inspect the chamfer surface and record the type of attack in relation to the reference line.

## 7 Determination of fracture toughness

### 7.1 Apparatus

**7.1.1 Broach or other cutting equipment**, capable of cutting a notch of uniform depth, of included angle  $45 \pm 2^\circ$ , such that the variation in wall thickness as measured from the outside surface to the notch tip does not exceed 0,1 mm. The tip of the notch shall have a radius not exceeding 0,025 mm. To ensure that this is so, the broach or cutting equipment shall be sharpened every 500 cuts.

**7.1.2 Loading device**, capable of applying the required force to the test piece such that the maximum initial change in the moment arm ( $d_m$ ) is not greater than  $d_m \pm 2\%$  (see Figure 1).

**7.1.3 Timing device**, accurate to  $\pm 1$  s over a period of 15 min.

**7.1.4 Rigid support clamps**, an example of which is shown in Figure 2. The support clamps shall have an inside radius equal to the outside radius of the pipe and shall be sufficiently rigid to maintain this radius under the load imposed by the test mass ( $m$ ).

NOTE The clamps maintain the geometry of the C-ring, which ensures that a controlled bending moment is transmitted to the notched section, and this has been accounted for in the method of calculation.

**7.1.5 Mounting device**, capable of mounting the assembly such that under load the rotation of the specimen is prevented.

NOTE Rotation of the specimen would shorten the moment arm ( $d_m$ ) (see Figure 2). A counter balance is one method of restricting the rotation.

**7.1.6 Balance**, capable of weighing to an accuracy of  $\pm 5$  g.

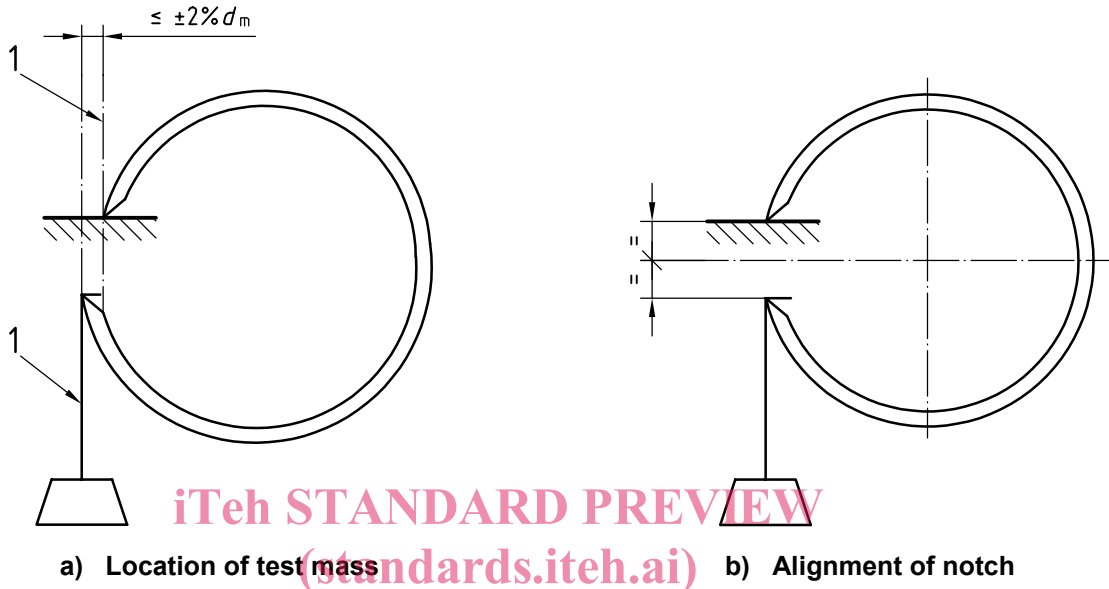

**Key**

1 centre line of support

ISO 11673:2005

<https://standards.iteh.ai/catalog/standards/sist/782ce5dc-2b87-4629-94a5-a745c51973a4/iso-11673-2005>

**Figure 1 — Tolerance on location of test mass and notch after test mass applied**