



SLOVENSKI STANDARD
SIST EN 13146-3:2012

01-julij-2012

Nadomešča:
SIST EN 13146-3:2004

Železniške naprave - Zgornji ustroj - Preskušanje pritrdilnih sistemov - 3. del:
Ugotavljanje popuščenja zaradi udarne obremenitve

Railway applications - Track - Test methods for fastening systems - Part 3:
Determination of attenuation of impact loads

Bahnanwendungen - Oberbau - Prüfverfahren für Schienenbefestigungssysteme - Teil 3:
Bestimmung der Dämpfung von Stosslasten

Applications ferroviaires - Voie - Méthodes d'essais pour les systèmes de fixation - Partie
3 : Détermination de l'atténuation des forces d'impact

Ta slovenski standard je istoveten z: EN 13146-3:2012

ICS:

93.100 Gradnja železnic Construction of railways

SIST EN 13146-3:2012 **en,de**

iTeh STANDARD PREVIEW
(standards.iteh.ai)

SIST EN 13146-3:2012

<https://standards.iteh.ai/catalog/standards/sist/83abc5e3-4d73-4c9f-8aed-e986e596f454/sist-en-13146-3-2012>

EUROPEAN STANDARD
NORME EUROPÉENNE
EUROPÄISCHE NORM

EN 13146-3

April 2012

ICS 93.100

Supersedes EN 13146-3:2002

English Version

Railway applications - Track - Test methods for fastening systems - Part 3: Determination of attenuation of impact loads

Applications ferroviaires - Voie - Méthodes d'essais pour les systèmes de fixation - Partie 3: Détermination de l'atténuation des forces d'impact

Bahnanwendungen - Oberbau - Prüfverfahren für Schienenbefestigungssysteme - Teil 3: Bestimmung der Dämpfung von Stoßlasten

This European Standard was approved by CEN on 26 November 2011.

CEN members are bound to comply with the CEN/CENELEC Internal Regulations which stipulate the conditions for giving this European Standard the status of a national standard without any alteration. Up-to-date lists and bibliographical references concerning such national standards may be obtained on application to the CEN-CENELEC Management Centre or to any CEN member.

This European Standard exists in three official versions (English, French, German). A version in any other language made by translation under the responsibility of a CEN member into its own language and notified to the CEN-CENELEC Management Centre has the same status as the official versions.

CEN members are the national standards bodies of Austria, Belgium, Bulgaria, Croatia, Cyprus, Czech Republic, Denmark, Estonia, Finland, France, Germany, Greece, Hungary, Iceland, Ireland, Italy, Latvia, Lithuania, Luxembourg, Malta, Netherlands, Norway, Poland, Portugal, Romania, Slovakia, Slovenia, Spain, Sweden, Switzerland, Turkey and United Kingdom.

[SIST EN 13146-3:2012](https://standards.iteh.ai/catalog/standards/sist/83abc5e3-4d73-4c9f-8aed-e986e596f454/sist-en-13146-3-2012)

<https://standards.iteh.ai/catalog/standards/sist/83abc5e3-4d73-4c9f-8aed-e986e596f454/sist-en-13146-3-2012>



EUROPEAN COMMITTEE FOR STANDARDIZATION
COMITÉ EUROPÉEN DE NORMALISATION
EUROPÄISCHES KOMITEE FÜR NORMUNG

Management Centre: Avenue Marnix 17, B-1000 Brussels

Contents	Page
Foreword	3
1 Scope.....	4
2 Normative references	4
3 Terms and definitions, symbols and abbreviations	4
3.1 Terms and definitions.....	4
3.2 Symbols and abbreviations	4
4 Principle	5
5 Apparatus	5
5.1 Concrete sleeper or bearer	5
5.2 Support.....	5
5.2.1 Reference method.....	5
5.2.2 Alternative method.....	6
5.3 Rail.....	6
5.4 Strain measuring and recording equipment	6
5.5 Drop mass.....	6
5.6 Preloading equipment	7
6 Test specimens	7
6.1 Concrete sleeper or bearer	7
6.2 Fastening	7
7 Procedure – Reference method.....	8
7.1 Preparation.....	8
7.2 Testing.....	8
7.3 Check on sleeper condition	8
7.4 Calculation	8
8 Procedure – Alternative method.....	9
8.1 Preparation	9
8.2 Testing and checking	9
8.3 Calculation	9
9 Test report	9
Annex A (informative) Sample calculation.....	11

Foreword

This document (EN 13146-3:2012) has been prepared by Technical Committee CEN/TC 256 "Railway applications", the secretariat of which is held by DIN.

This European Standard shall be given the status of a national standard, either by publication of an identical text or by endorsement, at the latest by October 2012, and conflicting national standards shall be withdrawn at the latest by October 2012.

Attention is drawn to the possibility that some of the elements of this document may be the subject of patent rights. CEN [and/or CENELEC] shall not be held responsible for identifying any or all such patent rights.

This document supersedes EN 13146-3:2002.

This document has been prepared under a mandate given to CEN by the European Commission and the European Free Trade Association.

Detailed changes only have been made in this revision of EN 13146-3:2002.

This European Standard is one of the series EN 13146 "Railway applications — Track — Test methods for fastening systems" which consists of the following parts:

- Part 1: Determination of longitudinal rail restraint;
- Part 2: Determination of torsional resistance;
- Part 3: Determination of attenuation of impact loads;
- Part 4: Effect of repeated loading;
- Part 5: Determination of electrical resistance;
- Part 6: Effect of severe environmental conditions;
- Part 7: Determination of clamping force;
- Part 8: In service testing;
- Part 9: Determination of stiffness.

These support the requirements in the series EN 13481 "Railway applications — Track — Performance requirements for fastening systems".

According to the CEN/CENELEC Internal Regulations, the national standards organizations of the following countries are bound to implement this European Standard: Austria, Belgium, Bulgaria, Croatia, Cyprus, Czech Republic, Denmark, Estonia, Finland, France, Germany, Greece, Hungary, Iceland, Ireland, Italy, Latvia, Lithuania, Luxembourg, Malta, Netherlands, Norway, Poland, Portugal, Romania, Slovakia, Slovenia, Spain, Sweden, Switzerland, Turkey and the United Kingdom.

EN 13146-3:2012 (E)**1 Scope**

This European Standard specifies laboratory test procedures for applying an impact to a rail fastened to a concrete sleeper or bearer which simulates the impact loading caused by traffic on railway tracks and measuring the strain induced in the sleeper. They are used for comparing the attenuation of impact loads on concrete sleepers or bearers by different rail pads. A reference procedure and alternative procedure are included.

This test is only applicable to ballasted track.

These test procedures apply to a complete fastening assembly.

2 Normative references

The following documents, in whole or in part, are normatively referenced in this document and are indispensable for its application. For dated references, only the edition cited applies. For undated references, the latest edition of the referenced document (including any amendments) applies.

EN 13146-9:2009, *Railway applications — Track — Test methods for fastening systems — Part 9: Determination of stiffness*

EN 13230-1, *Railway applications — Track — Concrete sleepers and bearers — Part 1: General requirements*

EN 13230-2, *Railway applications — Track — Concrete sleepers and bearers — Part 2: Prestressed monoblock sleepers*

EN 13230-3, *Railway applications — Track — Concrete sleepers and bearers — Part 3: Twin-block reinforced sleepers* <https://standards.iteh.ai/catalog/standards/sist/83abc5e3-4d73-4c9f-8aed-e986e596f454/sist-en-13146-3-2012>

EN 13481-1:2012, *Railway applications — Track — Performance requirements for fastening systems — Part 1: Definitions*

3 Terms and definitions, symbols and abbreviations**3.1 Terms and definitions**

For the purposes of this document, the terms and definitions given in EN 13481-1:2012 apply.

3.2 Symbols and abbreviations

For the purposes of this document, the following symbols apply.

a	attenuation expressed as per cent reduction in sleeper strain with test pad compared with reference pad;
a_t	attenuation at the top of the sleeper, in %;
a_b	attenuation at the bottom of the sleeper, in %;
d_a	thickness of aluminium plate used with rail pad, in mm;
d_t	thickness of rail pad for which assembly is designed, in mm;
M_{dr}	positive bending moment at the rail seat of the sleeper, in kNm;

δ	vertical deflection, in mm;
ε_{pct}	first peak strain in the top of the sleeper with test pad when subject to impact loading;
ε_{pcb}	first peak strain in the bottom of the sleeper with test pad;
$\varepsilon_{\text{pcrt}}$	mean first peak strain in the top of the sleeper with reference pad when subject to impact loading;
$\varepsilon_{\text{pcrb}}$	mean first peak strain in the bottom of the sleeper with reference pad;
ε_{st}	strain in the top of the sleeper due to static preload in alternative test procedure;
ε_{sb}	strain in the bottom of the sleeper due to static preload.

4 Principle

An impact load is applied by dropping a mass onto the head of a rail fastened to a concrete sleeper. The effect of the impact is measured as strain in the concrete sleeper. The impact attenuation of a fastening system is assessed by comparing the strains induced with a low attenuation reference rail pad in the fastening system and with the test pad in the fastening system.

With a reference pad in the system the strain induced by the impact load shall not exceed 80 % of the rail seat resistance moment of the sleeper (M_{dr} in accordance with EN 13230-1) at the gauge positions. The drop mass, drop height and resilience of the striking head are adjusted to ensure the limit on strain is not exceeded. Without subsequent change to the drop mass, drop height and striking head, the procedure is repeated with the test pad.

NOTE The test result is not very sensitive to the test load.

iTeh STANDARD PREVIEW
(standards.iteh.ai)

5 Apparatus

[SIST EN 13146-3:2012](#)

[https://standards.iteh.ai/catalog/standards/sist/83abc5e3-4d73-4c9f-8aed-](https://standards.iteh.ai/catalog/standards/sist/83abc5e3-4d73-4c9f-8aed-36e596f454/sist-en-13146-3-2012)

5.1 Concrete sleeper or bearer

An uncracked concrete sleeper or bearer, made without modification for this test, of the correct rail seat dimensions for the fastening assembly to be tested. The sleeper shall have two resistance strain gauges of (100 to 120) mm nominal gauge length bonded to the side of the sleeper symmetrically about a line through the centre of the rail seat normal to the base of the sleeper. The gauges shall be parallel to the base of the sleeper with one gauge as close as possible to the top of the sleeper rail seat, but avoiding any edge chamfer or radius, and the other gauge at least 10 mm but not more than 25 mm above the base of the sleeper as shown in Figure 1.

NOTE The sleeper designer or manufacturer should provide the calculated resistance moment at the gauge positions.

5.2 Support

5.2.1 Reference method

The support shall consist of a bed of crushed stone with nominal particle size in the range (5 to 15) mm contained in a tank. The bed shall be continuous for the full length of monoblock sleepers and bearers, and continuous under each block of two block sleepers. The support shall permit a vertical deflection of the sleeper of ($0,1 \leq \delta \leq 0,5$) mm when a sleeper supported on it is subject to an increase in static load from 50 kN to 60 kN at one rail seat

NOTE A suitable depth of crushed stone is 270 mm below the sleeper and a total depth of 370 mm.

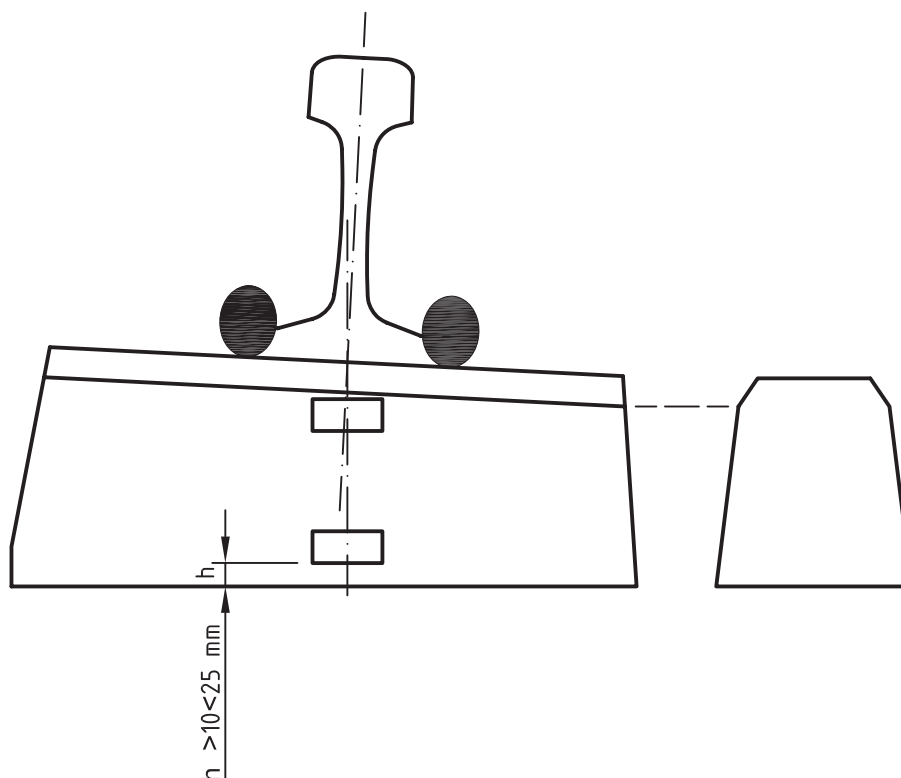
**Key**

h height of base of strain gauge above base of sleeper $10 \text{ mm} < h \leq 25 \text{ mm}$

Figure 1 — Position of strain gauges

5.2.2 Alternative method

For the alternative method, the support shall consist of a rubber mat on a firm base. The support shall permit a vertical deflection of $(0,1 \leq \delta \leq 0,5) \text{ mm}$ when a sleeper supported on it is subject to an increase in static load from 50 kN to 60 kN at one rail seat.

5.3 Rail

A piece of rail (0,3 to 1,0) m long of the section for which the fastening assembly is designed.

5.4 Strain measuring and recording equipment

Instruments which process the output from the strain gauges and provide a record of strain vs. time with a definition of not less than 0,1 ms. The output from the strain gauges shall be measured to $\pm 0,1 \text{ mV}$.

5.5 Drop mass

The combination of mass and drop height shall be such that the strain measured at each gauge position shall be less than 80 % of the calculated cracking strain of the sleeper and the time interval for the initial impulse of load shall be 1 ms to 5 ms.

A typical drop mass is shown in Figure 2.

NOTE The strain should be sufficient to be accurately measured.

5.6 Preloading equipment

A set of springs with a total effective stiffness of less than 2 MN/m capable of applying a vertical preload of 50 kN to the rail.

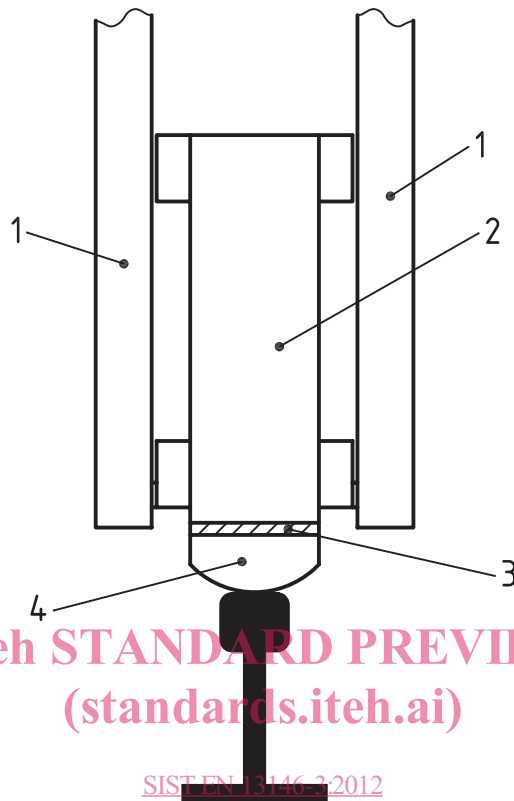

iTeh STANDARD PREVIEW
(standards.iteh.ai)

SIST EN 13146-3:2012

<https://standards.iteh.ai/catalog/standards/sist/83abc5e3-4d73-4c9f-8aed-e986e596f454/sist-en-13146-3-2012>

Key

- 1 guides
- 2 tup
- 3 rubber pad
- 4 tup head

Figure 2 — Typical drop mass

6 Test specimens

6.1 Concrete sleeper or bearer

As described in 5.1.

6.2 Fastening

The complete fastening assembly including all components and baseplate, where appropriate.