**Underground installation of flexible
glass-reinforced pipes based on
unsaturated polyester resin (GRP-UP) —**

**Part 1:
Installation procedures**

*Installation enterrée de canalisations flexibles renforcées de fibres de
verre à base de résine polyester insaturée (GRP-UP) —*

Partie 1: Modes opératoires d'installation

Document Preview

ISO/TS 10465-1:2007

<https://standards.iteh.ai/catalog/standards/iso/86c7f760-2cb2-4306-bcae-5884b6d0108b/iso-ts-10465-1-2007>



PDF disclaimer

This PDF file may contain embedded typefaces. In accordance with Adobe's licensing policy, this file may be printed or viewed but shall not be edited unless the typefaces which are embedded are licensed to and installed on the computer performing the editing. In downloading this file, parties accept therein the responsibility of not infringing Adobe's licensing policy. The ISO Central Secretariat accepts no liability in this area.

Adobe is a trademark of Adobe Systems Incorporated.

Details of the software products used to create this PDF file can be found in the General Info relative to the file; the PDF-creation parameters were optimized for printing. Every care has been taken to ensure that the file is suitable for use by ISO member bodies. In the unlikely event that a problem relating to it is found, please inform the Central Secretariat at the address given below.

iTeh Standards
(<https://standards.iteh.ai>)
Document Preview

[ISO/TS 10465-1:2007](https://standards.iteh.ai/catalog/standards/iso/86c7f760-2cb2-4306-bcae-5884b6d0108b/iso-ts-10465-1-2007)

<https://standards.iteh.ai/catalog/standards/iso/86c7f760-2cb2-4306-bcae-5884b6d0108b/iso-ts-10465-1-2007>



COPYRIGHT PROTECTED DOCUMENT

© ISO 2007

All rights reserved. Unless otherwise specified, no part of this publication may be reproduced or utilized in any form or by any means, electronic or mechanical, including photocopying and microfilm, without permission in writing from either ISO at the address below or ISO's member body in the country of the requester.

ISO copyright office
Case postale 56 • CH-1211 Geneva 20
Tel. + 41 22 749 01 11
Fax + 41 22 749 09 47
E-mail copyright@iso.org
Web www.iso.org

Published in Switzerland

Contents

Page

Foreword.....	v
Introduction	vi
1 Scope	1
2 Normative references	1
3 Terms and definitions.....	1
4 Installation — Design considerations.....	3
4.1 General.....	3
4.2 Site assessment.....	3
4.3 Flexible pipe — Technical concepts	4
4.4 Pipe selection	5
5 On-site inspection, transportation, handling and storage	6
5.1 Inspection	6
5.2 Transportation.....	7
5.3 Pipe handling	8
5.4 Storage.....	10
5.5 On-site inspection.....	11
6 Trench construction	12
6.1 Excavation	12
6.2 Minimum trench width.....	12
6.3 Trench-bottom.....	12
6.4 Water control.....	13
6.5 Support of trench walls	13
6.6 Trenching on slopes.....	14
6.7 Exposing pipes when making service-line connections	15
6.8 Trench bottom in weak soils	15
7 Foundation and bedding	15
7.1 General.....	15
7.2 Migration control of bedding materials	15
7.3 Trench foundation	16
7.4 Bedding.....	17
8 Pipe laying and jointing.....	17
8.1 Quality assurance	17
8.2 Pipe laying	18
8.3 Jointing pipes laid on steep gradients	18
9 Embedment and backfill	19
9.1 Pipe zone backfill configurations.....	19
9.2 Embedment materials.....	20
9.3 Placing and compacting embedment materials	21
9.4 Placement of trench backfill	22
9.5 Parallel or crossing piping systems	24
9.6 Special precautions	26
10 Thrust resistance and rigid connections	27
10.1 Support for control devices	27
10.2 Thrust restraint	28
10.3 Connections to rigid structures	29
10.4 Connections with rigid joints	31

11	Pipe joints	32
11.1	Joint characterization	32
11.2	Adhesive bonded joints	32
11.3	Butt and wrapped joints	32
11.4	Bolted flanged joints	32
11.5	Socket and spigot with elastomeric sealing elements	33
11.6	Flexible joints with elastomeric seal	33
11.7	Mechanical compression joints	33
11.8	Slip-on coupling	33
11.9	Mechanical band couplings	34
12	Special installations	34
12.1	Casings	34
12.2	Submarine pipelines	34
12.3	Embankment installations	37
13	Testing	38
13.1	Deflection testing	38
13.2	Pressure testing	38
13.3	Non-pressure pipelines	40
13.4	Pressure pipelines	41
14	Disinfection of water mains	42
14.1	Swabbing	42
14.2	Disinfection	42
Annex A (informative) Classification of soils and consolidation class terminology		43
Bibliography		45

iteh Standards
(<https://standards.iteh.ai>)
Document Preview

[ISO/TS 10465-1:2007](https://standards.iteh.ai/catalog/standards/iso/86c7f760-2cb2-4306-bcae-5884b6d0108b/iso-ts-10465-1-2007)

<https://standards.iteh.ai/catalog/standards/iso/86c7f760-2cb2-4306-bcae-5884b6d0108b/iso-ts-10465-1-2007>

Foreword

ISO (the International Organization for Standardization) is a worldwide federation of national standards bodies (ISO member bodies). The work of preparing International Standards is normally carried out through ISO technical committees. Each member body interested in a subject for which a technical committee has been established has the right to be represented on that committee. International organizations, governmental and non-governmental, in liaison with ISO, also take part in the work. ISO collaborates closely with the International Electrotechnical Commission (IEC) on all matters of electrotechnical standardization.

International Standards are drafted in accordance with the rules given in the ISO/IEC Directives, Part 2.

The main task of technical committees is to prepare International Standards. Draft International Standards adopted by the technical committees are circulated to the member bodies for voting. Publication as an International Standard requires approval by at least 75 % of the member bodies casting a vote.

In other circumstances, particularly when there is an urgent market requirement for such documents, a technical committee may decide to publish other types of normative document:

- an ISO Publicly Available Specification (ISO/PAS) represents an agreement between technical experts in an ISO working group and is accepted for publication if it is approved by more than 50 % of the members of the parent committee casting a vote;
- an ISO Technical Specification (ISO/TS) represents an agreement between the members of a technical committee and is accepted for publication if it is approved by 2/3 of the members of the committee casting a vote.

An ISO/PAS or ISO/TS is reviewed after three years in order to decide whether it will be confirmed for a further three years, revised to become an International Standard, or withdrawn. If the ISO/PAS or ISO/TS is confirmed, it is reviewed again after a further three years, at which time it must either be transformed into an International Standard or be withdrawn.

Attention is drawn to the possibility that some of the elements of this document may be the subject of patent rights. ISO shall not be held responsible for identifying any or all such patent rights.

ISO/TS 10465-1 was prepared by Technical Committee ISO/TC 138, *Plastics pipes, fittings and valves for the transport of fluids*, Subcommittee SC 6, *Reinforced plastics pipes and fittings for all applications*.

This first edition of ISO/TS 10465-1 cancels and replaces ISO/TR 10465-1:1993, of which it constitutes a technical revision.

ISO 10465 consists of the following parts, under the general title *Underground installation of flexible glass-reinforced pipes based on unsaturated polyester resin (GRP-UP)*:

- *Part 1: Installation procedures* [Technical Specification]
- *Part 2: Comparison of static calculation methods* [Technical Report]
- *Part 3: Installation parameters and application limits* [Technical Report]

Introduction

Work in ISO/TC 5/SC 6 (forerunner to ISO/TC 138/SC 6) on writing standards for the use of glass-reinforced plastics (GRP) pipe and fittings was approved at that subcommittee's meeting in Oslo in 1979. An *ad-hoc* group was established and the responsibility for drafting various standards later given to the Task Group that would become ISO/TC 138/SC 6.

At the ISO/TC 138/SC 6 meeting in London in 1980, Sweden proposed that a Working Group be formed to develop documents regarding a code of practice for GRP pipes. This was approved by the subcommittee and Working Group 4 (WG 4) formed for the purpose. Since 1982, many WG 4 meetings have been held and have considered the following matters:

- procedures for the underground installation of pipes;
- pipe/soil interaction with pipes having different stiffness values;
- minimum design parameters;
- an overview of various static calculation methods.

During this work it became evident that a unanimous agreement could not be reached within the Working Group on the specific methods to be employed. It was therefore agreed that the related documents would be published as either Technical Specifications — the case for this part of ISO 10465 — or Technical Reports.

This part of ISO 10465 describes procedures for the underground installation of GRP pipes. It concerns particular stiffness classes for which performance requirements have been specified in at least one product standard; but it can also be used as a guide for the installation of pipes of other stiffness classes.

ISO/TR 10465-2 presents a comparison of the two primary methods used internationally for static calculations on underground GRP pipe installations:

- a) the ATV method [1];
- b) the AWWA method [2].

ISO/TR 10465-3 gives additional information which is useful for static calculations primarily when using an ATV-A 127 type design system in accordance with ISO/TR 10465-2 of items such as

- parameters for deflection calculations,
- soil parameters, strain coefficients and shape factors for flexural-strain calculations,
- soil moduli and pipe stiffness for buckling calculations with regard to elastic behaviour,
- parameters for re-rounding and combined-loading calculations,
- the influence of traffic loads,
- the influence of sheeting,
- safety factors,
- allowable depth of cover for different pipe stiffnesses in different native soils,

- minimum pipe stiffness, depth of cover and compaction for GRP pipes installed under traffic surfaces,
- minimum pipe stiffness in relation to embedment conditions for GRP pipes which need to sustain negative pressures,
- re-rating of pressure pipes which are used under conditions, such as depth of cover, other than those for which the standard pipe has been designed, and
- the influence of sheeting on allowable depth of cover.

Since publication of the previous edition of this part of ISO 10465, both the AWWA and the ATV-DVWK design systems have been revised and now contain design features which reflect the increased knowledge and experience gained by the pipeline industry during the last decade. The revision of this and the other parts of ISO 10465 has been made to take account of those changes.

NOTE Although significant advances in trenchless construction have been made in recent years, this type of installation has not been considered.

iTeh Standards
(<https://standards.iteh.ai>)
Document Preview

[ISO/TS 10465-1:2007](https://standards.iteh.ai/catalog/standards/iso/86c7f760-2cb2-4306-bcae-5884b6d0108b/iso-ts-10465-1-2007)

<https://standards.iteh.ai/catalog/standards/iso/86c7f760-2cb2-4306-bcae-5884b6d0108b/iso-ts-10465-1-2007>

Underground installation of flexible glass-reinforced pipes based on unsaturated polyester resin (GRP-UP) —

Part 1: Installation procedures

1 Scope

This part of ISO 10465 describes the procedures for underground installation of flexible glass-reinforced thermosetting resin (GRP) pipes. It refers generally to GRP pipes as specified in the system standards ISO 10467 and ISO 10639, but it can also be used as a guide for the installation of other GRP pipes. It does not include jacking, relining or above-ground installations; nor does it cover health and safety or environmental conditions, these being addressed in national regulations at the place of installation.

NOTE The installation nomenclature, dimensions and soil moduli zones referred to in this part of ISO 10465 are shown in Figure 1.

2 Normative references

The following referenced documents are indispensable for the application of this document. For dated references, only the edition cited applies. For undated references, the latest edition of the referenced document (including any amendments) applies.

ISO 10467, *Plastics piping systems for pressure and non-pressure drainage and sewerage — Glass-reinforced thermosetting plastics (GRP) systems based on unsaturated polyester (UP) resin*

ISO 10639, *Plastics piping systems for pressure and non-pressure water supply — Glass-reinforced thermosetting plastics (GRP) systems based on unsaturated polyester (UP) resin*

3 Terms and definitions

For the purposes of this document, the following terms and definitions apply.

3.1

trench-stops

dams or weirs built around the pipe across the trench to prevent flow of water along the trench through the bedding and foundation materials

NOTE Trench-stops can be formed from clay which may be available on-site, or from bags of sand, or cement stabilized sand, packed around the pipe and across the trench extending to within 150 mm of the finished surface.

3.2

bulkhead

concrete wall poured around the pipe and spanning the trench

NOTE The bulkhead is keyed into the trench walls to form a pipe anchor and extends to within 150 mm of the finished surface level. Drainage holes are normally placed at the lower part of the embedment zone to eliminate long-term retention of water behind the bulkhead. See Figure 1.

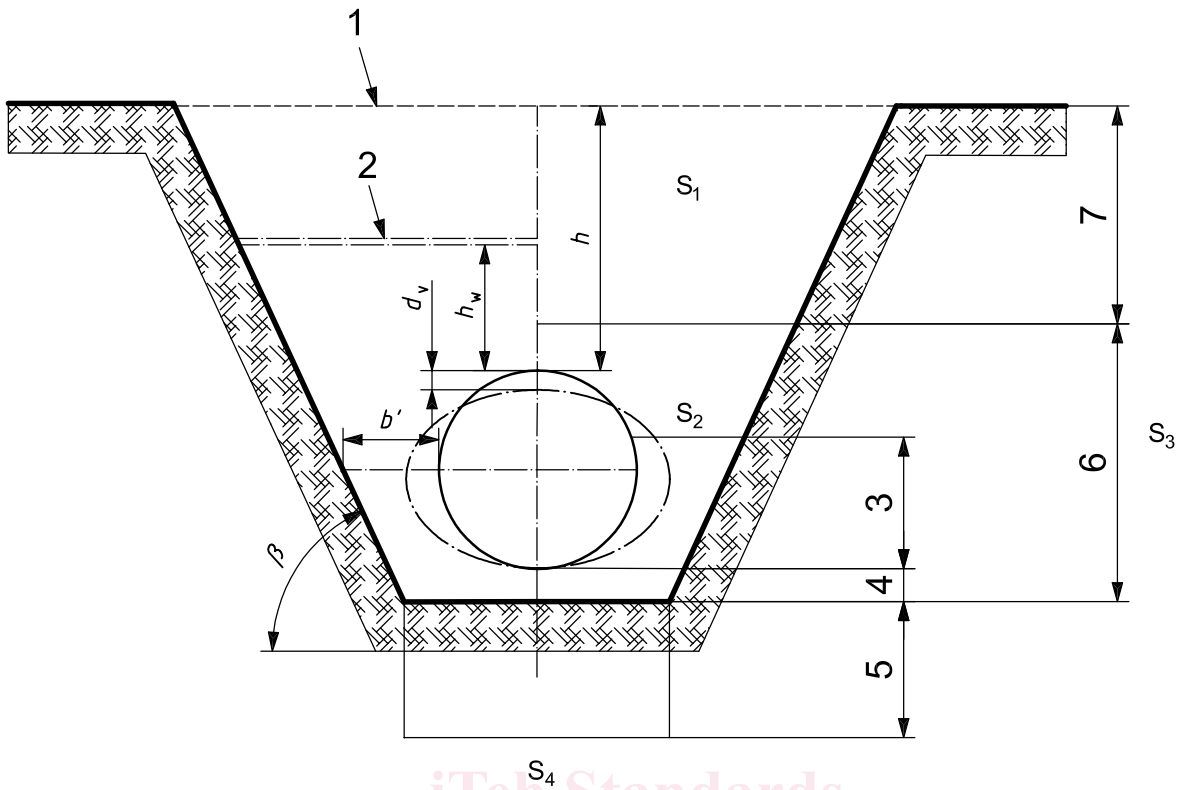

Key

- b' distance from trench wall to pipe
 - d_v vertical deflection
 - h depth of cover to top of pipe
 - h_w height of water surface above pipe
 - S_1 trench backfill above pipe embedment ^a
 - S_2 pipe embedment ^a
 - S_3 undisturbed native soil to side of trench ^a
 - S_4 undisturbed soil below trench ^a
 - β trench wall angle,
 - 1 ground-level
 - 2 water table level
 - 3 thickness of primary embedment
 - 4 thickness of bedding
 - 5 thickness of foundation (if required)
 - 6 pipe embedment
 - 7 thickness of backfill
- ^a Soil moduli zones.

Figure 1 — Trench installation nomenclature, dimensions and soil moduli zones

4 Installation — Design considerations

4.1 General

Glass-reinforced thermosetting resin (GRP) pipes are classed as flexible pipes which are designed to deflect under external load to an extent that does not cause structural damage to the pipe. The performance of GRP pipes is primarily controlled by the external and internal loads applied and the resistance provided by the embedment conditions. Allowable strain levels within the pipe wall vary, depending upon

- a) the type of raw materials used to manufacture the pipe,
- b) pipes wall formation, and
- c) manufacturing process.

Several installation design procedures exist which can be used to determine the deflection that can be expected in a particular installation. In ISO/TR 10465-2, the two most commonly used procedures — namely, the German ATV 127^[1] method and the American AWWA M 45^[2] method — are compared.

For a particular pipeline, the optimum pipe installation system employed will be governed both technically and economically by the site conditions. Nevertheless, due to the differences in geological formation that have occurred during the life of the earth, a diverse range of soils and geophysical conditions exists. For these reasons, Clause 7 and Clause 9 to Annex A contain only information that is relevant internationally. Any pipeline installation system shall be in accordance with the applicable national standards and regulations in force at the place of installation.

4.2 Site assessment

The topics in this subclause cover matters which should always be considered when surveying a site.

4.2.1 Water-table level

Water tables that are higher than the bottom of the trench can produce problems such as a reduction in passive resistance, erosion of trench sides, migration of fines within the embedment, instability of the trench, possibility of pipe floatation and inadequate foundation. Where a site has a high water table, consideration should be given to additional ground drainage and the use of suitable installation design methods to cope with the possibility of the buried pipe floating during and after installation. Additionally, the possibility of the water table changing over time should be surveyed using any existing shallow-drilled wells or springs, water levels in surface watercourses and reliable information from the local inhabitants.

4.2.2 Soil stability

During the site survey, locations which show signs of previous ground instability, i.e. slipping, faulting or uplifting/sinking should be investigated in detail. Fundamentally, the route of the pipeline should be selected to avoid such ground conditions. In cases where this is not possible, a detailed soil survey of the area should be conducted. This survey should be conducted with the assistance of an experienced geologist and/or soil mechanics engineer. Problems identified by the survey which have not been considered in the pipeline design should be discussed with pipeline designer/specifier.

4.2.3 Soil exploration

The actual ground conditions prevailing along the proposed route of the pipeline should be surveyed before beginning the design or installation. Geological features and the engineering properties of the soil are elements which will have an influence on the selection of the route, minimum pipe stiffness required, trench proportions and installation techniques to be employed.

The techniques to be employed during the survey will typically include at least one or more of the following: boring, sounding, physical survey, prospecting, water-table evaluation and determination of soil properties at

the site and in the laboratory. The degree of detail required from the survey will be specified by the responsible designer of the pipeline and will take into account the scale of pipeline, risk assessment and critical nature of the location.

4.2.4 Soil classifications

The ground conditions will vary at different locations along the intended route of a pipeline and it is important that an accurate description of the soil be given to the designers and contractors. To ensure an accurate assessment is made, the descriptors used in the report on the survey should be based on standards using the unified soil classification system (see Annex A) or be in accordance with the country's national design standard.

4.2.5 Location of existing pipeline utilities and structures

A preliminary site survey should be conducted along the route of the pipeline to ascertain whether other services such as water supply, sewerage, electricity or gas are present. Prior to commencing installation, precautions to prevent damage to existing services should be undertaken. The precautions should include minimum isolation distances to such services as may be prescribed by national regulations.

Furthermore, there is the possibility that historical or cultural assets could be encountered, and in such cases the regulations of the country or region shall be followed.

4.3 Flexible pipe — Technical concepts

Glass-reinforced thermosetting resin (GRP) pipes are classed as flexible pipes that may be expected to deflect under external load with no structural damage. The performance of GRP pipe is affected by the amount of strain induced in the pipe wall by external loads and/or internal pressure.

Allowable strain levels vary with the type of raw materials, wall structure and manufacturing process. It is necessary to control the deflection and distortion of the pipe to ensure that the manufacturer's allowable strain level is not exceeded.

In an underground installation, the soil and traffic loads above a buried flexible pipe cause a decrease in the vertical diameter and an increase in the horizontal diameter of the pipe. The horizontal movement of the pipe walls into the soil material at the sides of the pipe develops a passive resistance that helps the pipe support the external load. The resistance of the soil is affected by the type of soil, its density, depth of overburden and the presence of ground water. The higher the soil resistance, the less the pipe will deflect. Proper installation techniques are essential to develop the passive soil resistance required to prevent excessive pipe deflections and/or distortions.

The deflection of a buried flexible pipe depends on the soil and on the pipe. The amount of deflection is a function of the depth of burial, the stiffness of the pipe, the passive resistance of the soil at the sides of the pipe, the time-consolidation characteristics (time lag factor) of the soil and pipes, the applied live load and the degree of support given to the bottom of the pipe (bedding constant).

Several procedures exist that can be used to obtain the mathematical relationship of these parameters and the deflection that will occur in a particular installation.

NOTE In ISO/TR 10465-2, the two major design procedures ^[1], ^[2] are compared.

4.3.1 Behaviour of flexible pipes under load

The flexibility of GRP pipe combined with the natural structural behaviour of soils provides an ideal combination for transferring vertical load. Unlike rigid pipes, which may break under excessive vertical load, the GRP pipe's flexibility combined with its high strength allow it to bend and redistribute the load to the surrounding soil. The deflection of the pipe serves as an indicator of the stresses generated in the pipe and the quality of the installation.

The initial deflection is the deflection which is present following installation. The pipe continues slowly to have an increase in deflection but reaches a final value within a reasonable period of time. Almost all of the increase in deflection takes place during 1 to 2 years after installation and thereafter the deflection stabilizes. It is not unusual for the long-term deflection value to be 30 % to 50 % higher than the average initial deflection. The change in deflection after installation is caused mainly by settlement and consolidation of the surrounding soil. If the pipeline is pressurized, the pipes will start to re-round and a reduction in deflection will occur.

The use of the installation procedures detailed in this part of ISO 10465 will minimize the levels of both the initial and final deflections.

4.3.2 Limiting deflection

There are several methods of structural design (see ISO/TR 10465-2 and ISO/TR 10465-3) that may be used to estimate the deflection of a pipe under load but, although they are capable of being in reasonable agreement, they do not give exactly the same answers for a given condition. For any particular method, the values calculated are usually the expected average deflections.

The property requirements for GRP-UP pipes in accordance with ISO 10467 and ISO 10639 assume that the maximum permissible initial deflection is 3 % and the maximum long-term deflection is 6 %. If the recommendations for installation in this part of ISO 10465 are followed, it is expected that the deflections achieved will be less than these limiting values.

4.4 Pipe selection

The selection of the pressure class, stiffness class and joint type of a buried pipe system is based on the operational conditions of the pipeline (operating pressure, surge pressure and possible vacuum conditions) as well as on the external forces applied to the pipe from soil loading and superimposed live or traffic loading.

As the operating and burial conditions can vary over the length of a pipeline, the selected pressure and stiffness classes can differ at different locations along the pipeline. Depending on such factors as how pressure thrust is accommodated and the need to connect to fittings and other systems, joint selection can also differ along the course of a pipeline.

4.4.1 Pressure class selection

The selection of the appropriate pressure class for a pipe at any particular location in a pipeline system requires either knowledge of the static head pressure or of the pumping pressure or system operating pressure. Typically, a hydraulic analysis will determine the acceptable flow velocities and identify areas of high static or pumping heads. Surge pressure conditions also need to be determined. An unusually high surge pressure could require a higher pressure class pipe.

Depending on the application and operation requirements of the pipeline system, the system designer may incorporate such items as head breakers, pressure reduction valves, pressure relief valves, orifice plates and surge suppressors to control the flow and pressure in the pipeline.

4.4.2 Pipe stiffness class selection

Before the necessary stiffness can be determined, the following need to be considered.

4.4.2.1 Soil survey

If a soil survey is carried out prior to construction, the native soil and the backfill material should be classified in accordance with Annex A. The classification will help in the selection of a suitable nominal stiffness in accordance with 4.4.2.2

The classification will also indicate the areas of suitable materials for pipe zone backfill, so that importation of material may be minimized. Native materials conforming to the recommendations of this part of ISO 10465 or

soil groups 1, 2, 3 and 4 (see Annex A) are all suitable as backfill in the pipe zone. If backfill materials have to be imported it is recommended that group 1 or 2 materials be used.

4.4.2.2 Matters influencing selection of suitable pipe stiffness

The selection of an appropriate pipe stiffness class for a pipeline will depend on a number of factors, including

- burial depth,
- trench width,
- native soil,
- pipe zone backfill material and its degree of compaction,
- water table location,
- traffic (live) loading conditions,
- surface surcharge loads,
- vacuum conditions, and
- the limiting properties of the pipes.

Calculations to determine the predicted deflection level of installed pipes should be performed (see ISO/TR 10465-2 and ISO/TR 10465-3 for discussion and information on the most common calculation systems for GRP pipe systems). The predicted deflection must be within the allowable deflection limits of the selected pipe.

If consideration is being given to the use of pipes with a nominal stiffness less than SN 2 000, the possible effect of high compaction effort producing distortion should also be considered. It is recommended that a stability analysis be made which investigates the effects of the loading from soil overburden and, if applicable, internal vacuum.

4.4.2.3 Joint selection

The selection of the joint type will depend on several factors, of which the key considerations are

- operating pressure,
- method of thrust restraint,
- need for joining to ancillary fittings and/or other piping materials, and
- system layout.

In many piping projects it will be common to have several different joining methods, each addressing a specific need in the most economical manner.

5 On-site inspection, transportation, handling and storage

5.1 Inspection

It is recommended that at the commencement of the pipeline installation project an inspection and test plan be prepared. The testing and inspection should routinely confirm that the project specification is being met.