



Designation: D 1238 – 04

## Standard Test Method for Melt Flow Rates of Thermoplastics by Extrusion Plastometer<sup>1</sup>

This standard is issued under the fixed designation D 1238; the number immediately following the designation indicates the year of original adoption or, in the case of revision, the year of last revision. A number in parentheses indicates the year of last reapproval. A superscript epsilon ( $\epsilon$ ) indicates an editorial change since the last revision or reapproval.

### 1. Scope\*

1.1 This test method covers measurement of the rate of extrusion of molten resins through a die of a specified length and diameter under prescribed conditions of temperature, load, and piston position in the barrel as the timed measurement is being made.

1.2 Procedure A is a manual cutoff operation based on time used for materials having flow rates that fall generally between 0.15 and 50 g/10 min. Procedure B is an automatically timed flow rate measurement used for materials having flows from 0.50 to 900 g/10 min. By both procedures, the piston travel is generally the same during the timed measurement; the piston foot is about 46 and 20.6 mm above the die. Comparable flow rates have been obtained by these procedures in interlaboratory round-robin measurements of several materials described in 13.1. Provision is made for calculation of melt volume-flow rate as well as melt mass-flow rate.

NOTE 1—Round-robin testing indicates this test method may be suitable at flow rates up to 1500 g/10 min if the timing clock resolves the elapsed time to the nearest 0.01 s.

NOTE 2—This test method and ISO 1133-1991 are technically equivalent.

1.3 *This standard does not purport to address the safety concerns, if any, associated with its use. It is the responsibility of the user of this standard to establish appropriate safety and health practices and determine the applicability of regulatory limitations prior to use.* Specific precautionary statements are given in 5.7, 10.2.12, and 14.1.2.

### 2. Referenced Documents

#### 2.1 ASTM Standards:<sup>2</sup>

D 618 Practice for Conditioning Plastics for Testing

D 883 Terminology Relating to Plastics

E 691 Practice for Conducting an Interlaboratory Study to

Determine the Precision of a Test Method

#### 2.2 ANSI Standard:

B46.1 on Surface Texture<sup>3</sup>

#### 2.3 ISO Standard:

ISO 1133-1991 Determination of the Melt-Mass Flow Rate (MFR) and the Melt Volume-Flow Rate (MVR) of Thermoplastics<sup>3</sup>

### 3. Terminology

#### 3.1 General:

3.1.1 For definition of some of the technical terms used in this test method refer to Terminology D 883.

### 4. Significance and Use

4.1 This test method is particularly useful for quality control tests on thermoplastics.

NOTE 3—Polymers having flow rates less than 0.15 or greater than 900 g/10 min may be tested by the procedures in this test method; however, precision data have not been developed.

4.2 This test method serves to indicate the uniformity of the flow rate of the polymer as made by an individual process and, in this case, may be indicative of uniformity of other properties. However, uniformity of flow rate among various polymers as made by various processes does not, in the absence of other tests, indicate uniformity of other properties.

4.3 The flow rate obtained with the extrusion plastometer is not a fundamental polymer property. It is an empirically defined parameter critically influenced by the physical properties and molecular structure of the polymer and the conditions of measurement. The rheological characteristics of polymer melts depend on a number of variables. Since the values of these variables occurring in this test may differ substantially from those in large-scale processes, test results may not correlate directly with processing behavior.

4.4 The flow rate of a material may be measured under any of the conditions listed for it in 8.2. Additional characterization of a material can be obtained if more than one condition is used. In case two conditions are employed, a Flow Rate Ratio (FRR) may be obtained by dividing the flow rate at one condition by the flow rate at the other condition.

<sup>3</sup> Available from American National Standards Institute (ANSI), 25 W. 43rd St., 4th Floor, New York, NY 10036.

<sup>1</sup> This test method is under the jurisdiction of ASTM Committee D20 on Plastics and is the direct responsibility of Subcommittee D20.30 on Thermal Properties (Section D20.30.08).

Current edition approved March 1, 2004. Published April 2004. Originally approved in 1965. Last previous edition approved in 2001 as D 1238 - 01 $\epsilon$ <sup>1</sup>.

<sup>2</sup> For referenced ASTM standards, visit the ASTM website, www.astm.org, or contact ASTM Customer Service at service@astm.org. For *Annual Book of ASTM Standards* volume information, refer to the standard's Document Summary page on the ASTM website.

\*A Summary of Changes section appears at the end of this standard.

5. Apparatus

5.1 *Plastometer:*

5.1.1 The apparatus shall be a dead-weight piston plastometer consisting of a thermostatically controlled heated steel cylinder with a die at the lower end and a weighted piston operating within the cylinder. The essential features of the plastometer, illustrated in Figs. 1 and 2, are described in 5.2-5.8. All dimensional measurements shall be made when the article being measured is at  $23 \pm 5^\circ\text{C}$ .

5.1.2 Relatively minor changes in the design and arrangement of the component parts have been shown to cause differences in results among laboratories. It is important, therefore, for the best interlaboratory agreement that the design adhere closely to the description herein; otherwise, it should be determined that modifications do not influence the results.

5.2 *Cylinder*—The steel cylinder shall be 50.8 mm in diameter, 162 mm in length with a smooth, straight hole  $9.5504 \pm 0.0076$  mm in diameter, displaced 4.8 mm from the cylinder axis. Wells for a thermal sensor (thermoregulator, thermistor, etc.) and thermometer shall be provided as shown in Fig. 1. A 3.2-mm plate shall be attached to the bottom of the cylinder to retain the die. A hole in this plate, centered under the die and countersunk from below, allows free passage of the extrudate. The cylinder may be supported by at least two

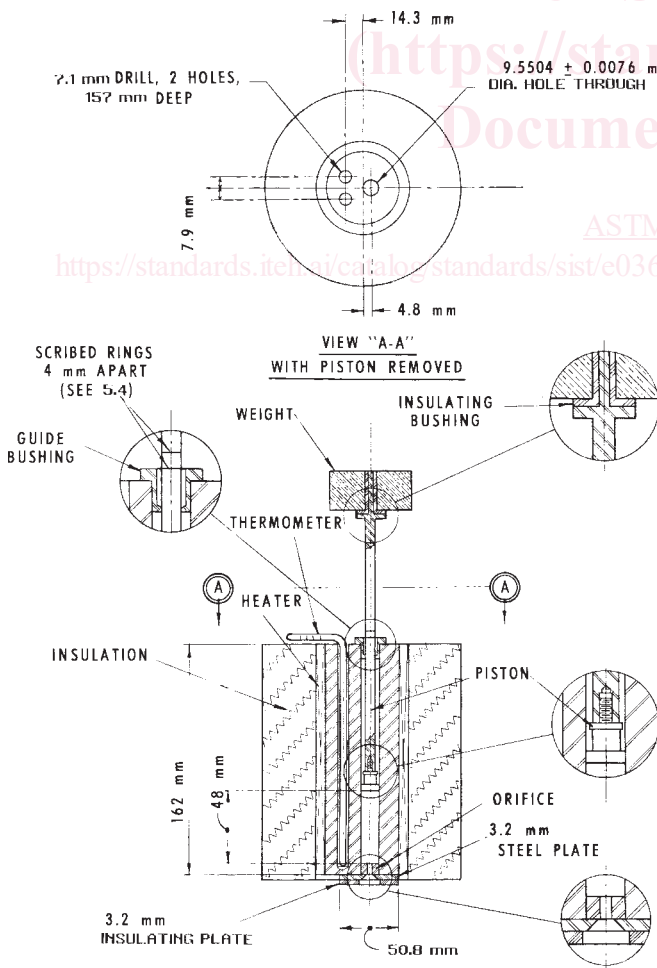

FIG. 1 General Arrangement of Extrusion Plastometer

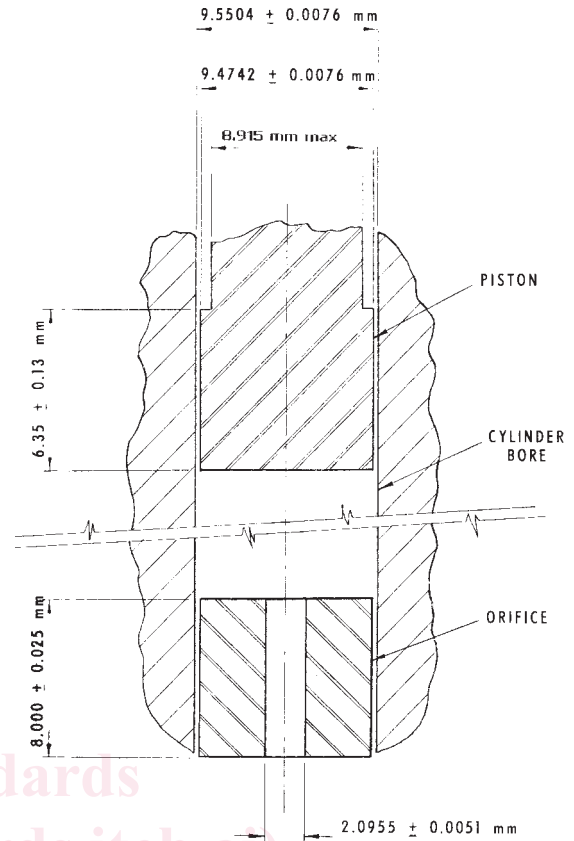

FIG. 2 Details of Extrusion Plastometer

6.4-mm high-strength screws at the top (radially positioned at right angles to the applied load) or by at least two 10-mm diameter rods screwed into the side of the cylinder for attaching to a vertical support. The essential dimensions of a satisfactory cylinder of this type are shown in Fig. 1 (Note 4). The cylinder bore should be finished by techniques known to produce approximately 12 rms or better in accordance with ANSI B46.1.

NOTE 4—Cylinders made of SAE 52100 or other equivalent steel heat-hardened to 60–65 Rockwell Hardness Scale C give good service when used at temperatures below  $200^\circ\text{C}$ . Cylinder liners of cobalt-chromium-tungsten alloy are also satisfactory to  $300^\circ\text{C}$ .

5.3 *Die*—The outside of the steel die shall be such diameter that it will fall freely to the bottom of the  $9.5504 \pm 0.0076$  mm diameter hole in the cylinder (Note 5). The die shall have a smooth straight bore  $2.0955 \pm 0.0051$  mm in diameter and shall be  $8.000 \pm 0.025$  mm in length. The bore and its finish are critical. It shall have no visible drill or other tool marks and no detectable eccentricity. The die bore shall be finished by techniques known to produce approximately 12 rms or better in accordance with ANSI B46.1.

NOTE 5—Recommended die material is tungsten carbide. Also satisfactory are steel, synthetic sapphire, and cobalt-chromium-tungsten alloy.

5.4 *Piston:*

5.4.1 The piston shall be made of steel with an insulating bushing at the top as a barrier to heat transfer from the piston to the weight. The land of the piston shall be  $9.4742 \pm 0.0076$  mm in diameter and  $6.35 \pm 0.13$  mm in length. The piston

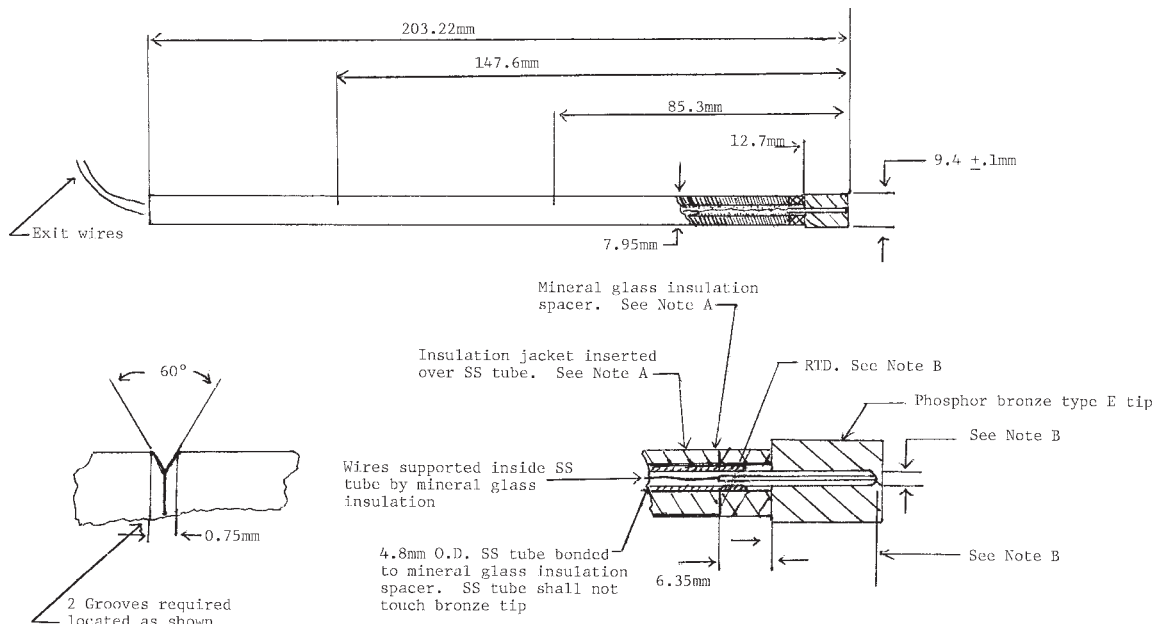

FIG. 3 Example of a Temperature Calibration Device

Note A—Mineral glass insulation or equivalent spacer shall be bonded to tip and SS tube. Bond material shall be low conductivity type, 400°C minimum rating. Insulation jacket material shall be low conductivity type (400°C minimum rating preferred, see Note 5).

Note B—The RTD shall be inserted into bronze tip and bonded using high conductivity, 400°C rated material. Tip of RTD element shall touch the bronze tip. Minimum insertion depth of 11.2 mm clearance between RTD and tip wall shall be minimized.

design may incorporate means for land replacement, for example, having threads and flats immediately above the land. Above the land, the piston shall be no larger than 8.915 mm in diameter (Note 6). The finish of the piston foot shall be 12 rms in accordance with ANSI B46.1. If wear or corrosion is a problem, the piston should be of stainless steel and equipped with a detachable foot for ease of replacement.

NOTE 6—To improve standardization it is preferable that the piston be guided with a loose-fitting metal sleeve at the top of the cylinder.

NOTE 7—Pistons of SAE 52100 steel with the bottom 25 mm, including the foot, hardened to a Rockwell hardness, C scale, of 55 to 59 have been found to give good service when used at temperatures below 200°C.

5.4.2 The piston shall be scribed with two reference marks 4 mm apart in such fashion that when the lower mark coincides with the top of the cylinder or other suitable reference point, the bottom of the piston is 48 mm above the top of the die (see Fig. 1).

5.4.3 The combined weight of piston and load shall be within a tolerance of ±0.5 % of the selected load.

5.5 Heater:

5.5.1 The equipment must have a heater capable of heating the apparatus so that the temperature at 10 mm above the die can be maintained within ±0.2°C of the desired temperature during the test. The temperature of the barrel, from 10 mm to 75 mm above the top of the die, must be maintained within ±1 % of the set temperature (°C).

NOTE 8—At temperatures higher than 200°C this degree of temperature control may be more difficult to obtain.

5.5.2 Calibrate the temperature-indicating device by means of a light-gage probe-type thermocouple or a platinum-

resistance temperature sensor having a short sensing length.<sup>4</sup> The thermocouple should be encased in a metallic sheath having a diameter of approximately 1.6 mm with its hot junction grounded to the end of the sheath. Insert the temperature sensor into the melt from the top of the cylinder so that it is 10 ± 1 mm above the upper face of the die. The temperature sensors shall be used with a potentiometer having a sensitivity of at least 0.005 mV, or a temperature readout having a sensitivity of at least 0.1°C. Calibration should also be verified at 75 mm above the upper face of the die. An alternate technique for calibration is to use a sheathed thermocouple or platinum-resistance temperature sensor with tip diameter of 9.4 ± 0.1 mm for insertion in the bore without material present. An example of this is shown in Fig. 3. Calibration of the temperature-indicating device shall be verified at each run temperature.

NOTE 9—The response of the temperature sensing device may be affected by immersion level. Take care to ensure adequate insulation of the device sensor and stabilization of the barrel temperature.

5.5.3 Heat shall be supplied by electric band heater(s) covering the entire length of the cylinder. The heater(s) may be single- or multi-element, depending upon the manufacturer's control means. The heater(s) plus control system must be capable of maintaining the temperature within the required ±0.2°C of the set point. The temperature sensor and readout equipment must be calibrated to a traceable national standard

<sup>4</sup> Round-robin data showing flow rate and corresponding temperature profile of the melt obtained using probe-type thermocouples and platinum resistance temperature sensors can be obtained from ASTM Headquarters. Request RR:D20-1094.

(that is, NIST) at least once per year. The cylinder with the heater(s) shall be lagged with 38 mm of foamed-glass insulation. An insulating plate 3.2 mm in thickness shall be attached to the bottom of the cylinder to minimize heat loss at this point.

5.6 *Temperature Controller*—The type of controller and sensor must be capable of meeting the required control tolerance specified in 5.5.1.

5.7 *Thermometer*—Thermometers having a range of 4°C graduated in 0.2°C divisions may be used to indicate temperature. The temperature at this point may not necessarily be the temperature of the material 10 mm above the die. The thermometer may be used to monitor indirectly the temperature of the material 10 mm above the die and may be calibrated by reference to a thermocouple or platinum resistance temperature sensor inserted in the material 10 mm above the die. See 5.5.2 for a description of a method for measuring temperature.

**Warning**—Caution should be observed with the use of a mercury-filled thermometer. Mercury vaporization occurs if the thermometer is broken. Mercury thermometers are not to be used at or above the boiling point of mercury, which is 357°C.

NOTE 10—Warning:

5.8 *Level*—Provision shall be made for vertical alignment of the bore of the extrusion plastometer. This is necessary to minimize subtractive loads resulting from rubbing or friction between the piston tip and sidewall. Means of alignment are discussed in Appendix X1.

5.9 *Accessory Equipment*—Necessary accessories include equipment for charging samples to the cylinder, a funnel, a die plug, a tool for cutting off the extruded sample, a timer or stop watch, cleaning equipment, go/no-go gages, a balance accurate to ±0.001 g, and, when required, a weight or weight-piston support.

NOTE 11—Satisfactory operation of the apparatus for polyethylenes can be ascertained by making measurements on NIST Standard Reference Materials (SRMs) certified for melt flow rate. The four SRMs certified under condition 190/2.16 are SRM 1473 with a flow rate of 1.29 g/min, SRM 1474 with a flow rate of 5.03 g/10 min, SRM 1496 with a flow rate of 0.26 g/10 min, and SRM 1497 with a flow rate of 0.19 g/10 min. SRM 1475a is certified under condition 190/3.25 with a flow rate of 2.20 g/10 min.<sup>5</sup>

## 6. Test Specimen

6.1 The test specimen may be in any form that can be introduced into the bore of the cylinder, for example, powder, granules, strips of film, or molded slugs. It may be desirable to preform or pelletize a powder.

## 7. Conditioning

7.1 Many thermoplastic materials do not require conditioning prior to testing. Materials which contain volatile components, are chemically reactive, or have other special characteristics most probably require appropriate conditioning procedures. Moisture not only affects reproducibility of flow rate measurement but, in some types of materials, degradation

is accelerated by moisture at the high temperatures used in testing. Check the applicable material specification for any conditioning requirements before using this test. See Practice D 618 for appropriate conditioning practices.

## 8. Procedural Conditions

8.1 Standard conditions of test are given in Table 1. Test conditions shall be shown as: Condition \_\_\_/\_\_\_, where the temperature in degrees Celsius is shown first, followed by the weight in kilograms. For example: Condition 190/2.16.

8.2 The following conditions have been found satisfactory for the material listed:

Material	Condition	
Acetals (copolymer and homopolymer)	190/2.16	190/1.05
Acrylics	230/1.2	230/3.8
Acrylonitrile-butadiene-styrene	200/5.0	230/3.8
	220/10	
Acrylonitrile/butadiene/styrene/polycarbonate blends	230/3.8	250/1.2
	265/3.8	265/5.0
Cellulose esters	190/0.325	190/2.16
	190/21.60	210/2.16
Ethylene-chlorotrifluoroethylene copolymer	271.5/2.16	
Ethylene-tetrafluoroethylene copolymer	297/5.0	
Nylon	275/0.325	235/1.0
	235/2.16	235/5.0
	275/5.0	
Perfluoro(ethylene-propylene) copolymer	372/2.16	
Perfluoroalkoxyalkane	372/5.0	
Polycaprolactone	125/2.16	80/2.16
Polychlorotrifluoroethylene	265/12.5	
Polyether sulfone (PES)	380/2.16	360/10
	343/2.16	
Polyethylene	125/0.325	125/2.16
	250/1.2	
	190/0.325	190/2.16
	190/21.60	190/10
	310/12.5	
Polycarbonate	300/1.2	
Polymonochlorotrifluoroethylene	265/21.6	
	265/31.6	
Polypropylene	230/2.16	
Polyphenyl sulfone (PPSU)	365/5.0	380/2.16
Polystyrene	200/5.0	230/1.2
	230/3.8	190/5.0
Polysulfone (PSU)	343/2.16	360/10
Polyterephthalate	250/2.16	210/2.16
	285/2.16	
Poly(vinyl acetal)	150/21.6	
Poly(vinylidene fluoride)	230/21.6	
	230/5.0	
Poly(phenylene sulfide)	315/5.0	
Styrene acrylonitrile	220/10	230/10
	230/3.8	
Styrenic Thermoplastic Elastomer	190/2.16	200/5.0
Thermoplastic Elastomer-Ether-Ester	190/2.16	220/2.16
	230/2.16	240/2.16
		250/2.16
Thermoplastic elastomers (TEO)	230/2.16	
Vinylidene fluoride copolymers	230/21.6	
	230/5.0	

for T<sub>m</sub> = 100° use 120/5.0 or 21.6

NOTE 12—Some materials may require special materials of construction or handling for performing this test. Please refer to the material specification for appropriate recommendations.

8.3 If more than one condition is used and the material is polyethylene, the determination of Flow Rate Ratio (FRR) has been found to be useful. The FRR is a dimensionless number derived by dividing the flow rate at Condition 190/10 by the flow rate at Condition 190/2.16.

NOTE 13—When determining such a ratio of flow rates for a material at

<sup>5</sup> These standard polyethylenes are available from the National Institute of Standards and Technology, Office of Standard Reference Materials, Washington, DC 20234.

**TABLE 1 Standard Test Conditions, Temperature, and Load**

Condition Standard Designation	Temperature, °C	Total Load Including Piston, kg	Approximate Pressure	
			kPa	psi
80/2.16	80	2.16		
125/0.325	125	0.325	44.8	6.5
125/2.16	125	2.16	298.2	43.25
150/2.16	150	2.16	298.2	43.25
190/0.325	190	0.325	44.8	6.5
190/2.16	190	2.16	298.2	43.25
190/21.60	190	21.60	2982.2	432.5
200/5.0	200	5.0	689.5	100.0
230/1.2	230	1.2	165.4	24.0
230/3.8	230	3.8	524.0	76.0
265/12.5	265	12.5	1723.7	250.0
275/0.325	275	0.325	44.8	6.5
230/2.16	230	2.16	298.2	43.25
190/1.05	190	1.05	144.7	21.0
190/10.0	190	10.0	1379.0	200.0
300/1.2	300	1.2	165.4	24.0
190/5.0	190	5.0	689.5	100.0
235/1.0	235	1.0	138.2	20.05
235/2.16	235	2.16	298.2	43.25
235/5.0	235	5.0	689.5	100.0
250/2.16	250	2.16	298.2	43.25
310/12.5	310	12.5	1723.7	250.0
210/2.16	210	2.16	298.2	43.25
285/2.16	285	2.16	298.2	43.25
315/5.0	315	5.0	689.5	100.0
372/2.16	372	2.16	298.2	43.25
372/5.0	372	5.0	689.5	100
297/5.0	297	5.0	689.5	100
230/21.6	230	21.6	2982.2	432.5
230/5.0	230	5.0	689.5	100
265/21.6	265	21.6	2982.2	432.5
265/31.6	265	31.6	4361.2	632.5
271.5/2.16	271.5	2.16	298.2	43.25
220/10	220	10.0	1379.0	200.0
250/1.2	250	1.2	165.4	24.0
265/3.8	265	3.8	524.0	76.0
265/5	265	5.0	689.5	100.0

the same temperature under different loads, it has been found that precision is maximized when one operator uses one Procedure (A or B), the same plastometer, and the same die for both measurements (the die need not be removed from the plastometer between the two determinations).

## 9. Procedure A—Manual Operation

9.1 Select conditions of temperature and load from Table 1 in accordance with material specifications such that flow rates will fall between 0.15 to 50 g/10 min.

9.2 Ensure that the bore of the extrusion plastometer is properly aligned in the vertical direction. (See Appendix X1.)

9.3 Inspect the apparatus and die for cleanliness. If it is not clean, see 9.11.

NOTE 14—The degree of cleanliness can significantly influence the flow rate results, therefore a thorough method of cleaning must be established. It has been found that three swabs of the barrel is satisfactory for most materials and that the die, barrel, and piston are more easily cleaned while hot.

9.4 Check the die bore diameter with appropriately sized no-go/go gages prior to testing. Make frequent checks to determine whether the die diameter (tested with die at  $23 \pm 5^\circ\text{C}$ ) is within the tolerances given in 5.3.

NOTE 15—Cleaning and usage can result in a die diameter that is out of specifications. Data has shown that erroneous results will be obtained if the die diameter is not within the appropriate tolerances.

9.5 Verify that the temperature is stable and within  $\pm 0.2^\circ\text{C}$  of the appropriate test temperature as specified in 5.5.1.4.

9.6 Insert the die and the piston. The temperature of the cylinder with the piston and die in place must be stable at the appropriate test temperature 15 min before testing is begun. When equipment is used repetitiously, it should not be necessary to heat the piston and die for 15 min.

NOTE 16—The reduction in heating time when the unit is being used repetitiously is only allowed when runs of the same or similar material are being measured over a continuous time frame. If the piston and die are removed and cleaned, they should be considered “cold” and the full 15 minutes heating stabilization time required.

9.7 Remove the piston and place it on an insulated surface. Charge the cylinder within 1 min with a weighed portion of the sample in accordance with the expected flow rate, as given in Table 2. Reinsert the piston and add the appropriate weight.

NOTE 17—Experience has shown that for the best reproducibility the piston should operate within the same part of the cylinder for each measurement. The piston is scribed so the starting point for each extrusion is roughly the same. Some excess of material over the minimum required for the actual flow measurement portion of the test is provided by the charging weights shown in Table 2. This is necessary to achieve a void-free extrudate and flow equilibrium before start of rate measurements.

NOTE 18—It is frequently helpful to take interim cuts of the extrudate at uniform time intervals during the specified extrusion time. Weights of

**TABLE 2 Standard Test Conditions, Sample Mass,<sup>A</sup> and Testing Time<sup>B</sup>**

Flow Range, g/10 min	Suggested Mass of Sample in Cylinder, g	Time Interval, min	Factor for Obtaining Flow Rate in g/10 min
0.15 to 1.0	2.5 to 3.0	6.00	1.67
>1.0 to 3.5	3.0 to 5.0	3.00	3.33
>3.5 to 10	4.0 to 8.0	1.00	10.00
>10 to 25	4.0 to 8.0	0.50	20.00
>25	4.0 to 8.0	0.25	40.00

<sup>A</sup> This is a suggested mass for materials with melt densities of about 0.7 g/cm<sup>3</sup>. Correspondingly, greater quantities are suggested for materials of greater melt densities. Density of the molten resin (without filler) may be obtained using the procedure described by Terry, B. W., and Yang, K., "A New Method for Determining Melt Density as a Function of Pressure and Temperature," *SPE Journal*, SPEJA, Vol. 20, No. 6, June 1964, p. 540 or the procedure described by Zoller, Paul, "The Pressure-Volume-Temperature Properties of Polyolefins," *Journal of Applied Polymer Science*, Vol 23, 1979, p. 1051. It may also be obtained from the weight of an extruded known volume of resin at the desired temperature. For example, 25.4 mm (1 in.) of piston movement extrudes 1.804 cm<sup>3</sup> of resin. An estimate of the density of the material can be calculated from the following equation:

$$\text{resin density at test temperature} = M/1.804$$

where:

$M$  = mass of extruded resin.

<sup>B</sup> See 9.14.

these individual cuts give an indication of the presence of bubbles which may be masked due to their size or to opacity of the sample. This technique is particularly helpful in the case of highly pigmented materials. Forcing out some of the resin manually during the preheat period often eliminates bubbles in the test extrudate.

9.8 Allow time for the material to soften and begin to melt, and then purge some material to a position such that subsequent travel of the piston will position the lower scribe mark at the reference start position  $7.0 \pm 0.5$  min from the completion of the charge. Purge must be completed at least 2 min prior to start of the test for materials having melt flow rates less than 10 g/10 min.

NOTE 19—It has been found that purging within 60 s of the start time will result in higher variability in the data.

NOTE 20—There may be cases where the  $7.0 \pm 0.5$  min is too much or not enough preheat time. For those materials, provisions must be in the material documents. It is necessary to refer to the appropriate material document before beginning any test.

NOTE 21—Additional care may be necessary to prevent thermal degradation in the extrusion plastometer. This is sometimes done by the addition of an appropriate antioxidant. For highly unstable materials, it may be necessary to use alternative techniques as an indication of flow characteristics.

9.9 For materials with flow rates greater than 10 g/10 min, a weight (and if needed, a piston) support must be used after the initial purge. The support shall be removed at such a time as to allow the test to begin within  $7 \pm 0.5$  min of the completion of the charge. The piston/weight support should be of such a length that the lower scribe mark of the supported piston/weight will be 25 mm above the top of the guide bushing or other suitable reference mark.

NOTE 22—It has been found that the effect of choosing plugging, weight support, or both, is significant to the flow rate results. The choice of piston support was made to cover all conditions and flow rates 10 to 50 g/10 min.

9.10 For all tests, start collecting a timed extrudate when requirements for the piston position are met, provided this is

within  $7.0 \pm 0.5$  min from the end of charging; otherwise, discard the charge and repeat the test with readjusted piston position after the initial purge, or change weights. Requirements are that the top scribed mark on the piston be visible above the cylinder or index and that the lower scribe mark be in the cylinder or below the index. As the lower scribed mark approaches the top of the cylinder or index, reset the timer to zero, then simultaneously start the timer and make the initial cut-off when the position requirements are met. Make the final cut-off exactly when the time interval given in Table 2 is reached. Collect the timed extrudate. If the extrudate contains visible bubbles, discard the complete charge and begin the test again.

NOTE 23—The charge weight should only be increased if no material is being purged and there is still not enough material to complete the test.

9.11 Discharge the remainder of the specimen and push the die out through the top of the cylinder. Swab out the cylinder with cloth patches after the manner of cleaning a pistol barrel. The die may be cleaned by dissolving the residue in a solvent. A better method is pyrolytic decomposition of the residue in a nitrogen atmosphere. Place the die in a tubular combustion furnace or other device for heating to  $550 \pm 10^\circ\text{C}$  and clean with a small nitrogen purge through the die. This method is preferable to flame or solvent cleaning, being faster than solvent cleaning and less detrimental to the die than an open flame. In certain cases where materials of a given class having similar flow characteristics are being tested consecutively, interim die cleaning may be unnecessary. In such cases, however, the effect of cleaning upon flow rate determination must be shown to be negligible if this step is avoided.

9.12 Once the extrudate is cool, weigh to the nearest 1 mg.

9.13 Multiply the weight of the extrudate by the appropriate factor shown in Table 2 to obtain the flow rate in grams per 10 min.

NOTE 24—Frequently, errors in test technique, apparatus geometry, or test conditions, which defy all but the most careful scrutiny exist, causing discrepancy in flow rate determinations. The existence of such errors is readily determined by periodically measuring a reference sample of known flow rate. The flow rate value and range to be tolerated can be determined using a statistically correct test program composed of multiple determinations with various instruments. Standard samples of polyethylene, linear or branched, are available from the National Institute of Standards and Technology.

9.14 In case a specimen has a flow rate at the borderline of the ranges in Table 2 and slightly different values are obtained at different time intervals, the referee value shall be obtained at the longer time interval.

## 10. Procedure B—Automatically Timed Flow Rate Measurement

### 10.1 Apparatus:

10.1.1 Extrusion plastometer and auxiliary equipment are detailed in Section 4 and below.

10.1.2 A timing device shall electrically, optically, or mechanically time piston movement within the specified travel range. The requirements of the system are as follows:

10.1.2.1 Sense and indicate the piston travel time within  $\pm 0.01$  s (see Note 1).