



## Standard Test Method for Behavior of Materials in a Vertical Tube Furnace at 750°C<sup>1</sup>

This standard is issued under the fixed designation E 136; the number immediately following the designation indicates the year of original adoption or, in the case of revision, the year of last revision. A number in parentheses indicates the year of last reapproval. A superscript epsilon (ε) indicates an editorial change since the last revision or reapproval.

*This standard has been approved for use by agencies of the Department of Defense.*

### 1. Scope

1.1 This fire-test-response test method covers the determination under specified laboratory conditions of combustion characteristics of building materials. It is not intended to apply to laminated or coated materials.

1.2 This test method references notes and footnotes that provide explanatory information. These notes and footnotes, excluding those in tables and figures, shall not be considered as requirements of this test method.

1.3 The values stated in SI units are to be regarded as standard. The values given in brackets are for information only.

1.4 *This standard is used to measure and describe the response of materials, products, or assemblies to heat and flame under controlled conditions, but does not by itself incorporate all factors required for fire-hazard or fire-risk assessment of the materials, products, or assemblies under actual fire conditions.*

1.5 *This standard does not purport to address all of the safety concerns, if any, associated with its use. It is the responsibility of the user of this standard to establish appropriate safety and health practices and determine the applicability of regulatory limitations prior to use.*

### 2. Referenced Documents

#### 2.1 ASTM Standards:<sup>2</sup>

- D 1929 Test Method for Ignition Properties of Plastics
- D 3174 Test Method for Ash in the Analysis Sample of Coal and Coke from Coal
- E 84 Test Method for Surface Burning Characteristics of Building Materials
- E 176 Terminology of Fire Standards

#### 2.2 ISO Standard:

ISO 1182 Noncombustibility Test for Building Materials<sup>3</sup>

#### 2.3 Other Standard:

BS 476 Combustibility Test of Materials<sup>3</sup>

### 3. Terminology

3.1 Definitions—For definitions of terms found in this test method, refer to Terminology E 176.

### 4. Significance and Use

4.1 While actual building fire exposure conditions are not duplicated, this test method will assist in indicating those materials which do not act to aid combustion or add appreciable heat to an ambient fire.

4.2 Materials passing the test are permitted limited flaming and other indications of combustion.

### 5. Apparatus

5.1 The apparatus, as shown in Fig. 1, shall consist primarily of the following:

5.1.1 *Refractory Tubes*—Two concentric, refractory tubes, 76 and 102 mm [3 and 4 in.] in inside diameter and 210 to 250 mm [8½ to 10 in.] in length, with axes vertical, and with heat applied by electric heating coils outside of the larger tube. A controlled flow of air is admitted tangentially near the top of the annular space between the tubes and passes to the bottom of the inner tube. The outer tube rests on a refractory bottom and the inner tube rests on three spacer blocks so as to afford a total opening under the inner tube equal to or greater than that of the annular space. The refractory bottom plate has a removable plug for cleaning.

5.1.2 *Transparent Cover*—A transparent cover of heat-resistant glass or other transparent material shall be provided over the top of the inner tubes. The cover shall have a circular opening  $28.7 \pm 0.8$  mm [ $1\frac{1}{8} \pm \frac{1}{32}$  in.] centered over the axis of the tubes. This opening has an area of 645 mm<sup>2</sup>[1.0 in.<sup>2</sup>]. The cover shall be in two equally-sized, movable parts.

5.1.3 *Thermocouples* and an automatically recording device shall be provided. The thermocouples shall be located as follows:

<sup>3</sup> Available from American National Standards Institute (ANSI), 25 W. 43rd St., 4th Floor, New York, NY 10036.

<sup>1</sup> This test method is under the jurisdiction of ASTM Committee E05 on Fire Standards and is the direct responsibility of Subcommittee E05.23 on Combustibility.

Current edition approved February 1, 2004. Published March 2004. Originally approved in 1958. Last previous edition approved in 1999 as E 136 – 99<sup>ε1</sup>.

<sup>2</sup> For referenced ASTM standards, visit the ASTM website, www.astm.org, or contact ASTM Customer Service at service@astm.org. For *Annual Book of ASTM Standards* volume information, refer to the standard's Document Summary page on the ASTM website.

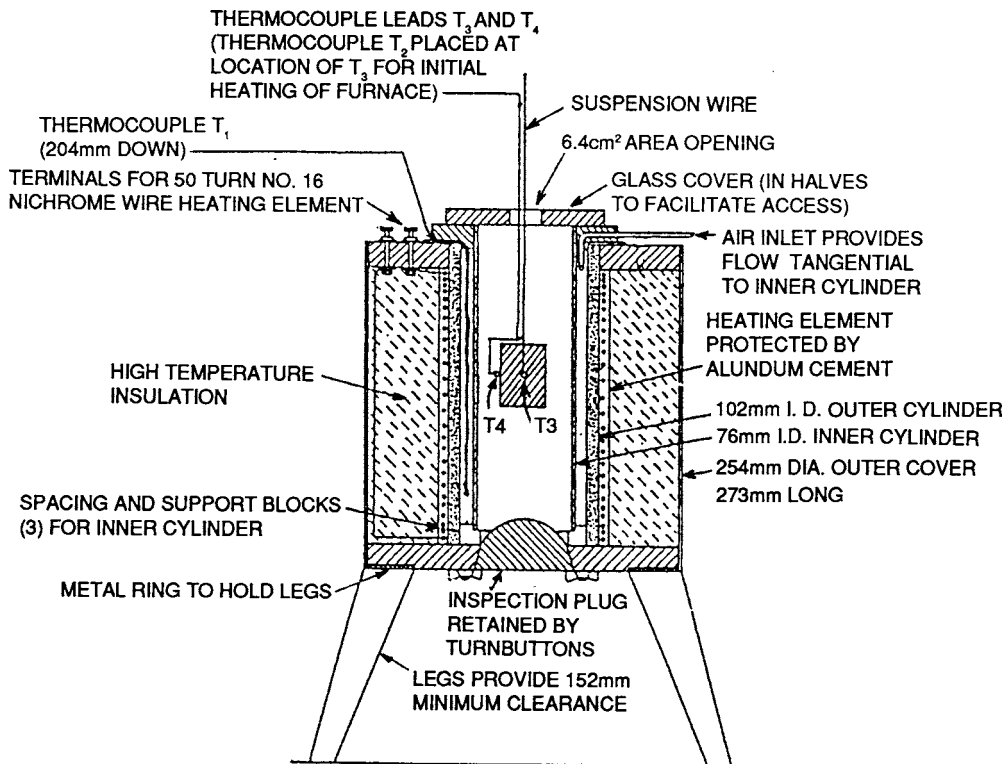

NOTE—Inch-Pound Equivalents

in.	3	4	6	10	10 $\frac{3}{4}$	1 in. <sup>2</sup>	No. 16 Awg
mm	76	102	152	254	273	6.4 cm <sup>2</sup>	1.29

FIG. 1 Cross Section of Furnace Assembly

ASTM E136-04

5.1.3.1 Thermocouple  $T_1$  is located in the center of the air space between the two concentric, refractory tubes; approximately 204 mm [8 in.] down from the top of the 102-mm [4-in.] diameter tube (Note 1).

5.1.3.2 Thermocouple  $T_3$  is located at the approximate geometric center of the specimen.

5.1.3.3 Thermocouple  $T_4$  is located on the surface, in contact with the specimen; in the same horizontal plane as  $T_3$ .

5.1.3.4 Thermocouples  $T_1$ ,  $T_3$  and  $T_4$  shall have a time constant (time to reach 63.2 % of the furnace air temperature of 750°C [1382°F]) of 5 to 10 s (Note 2).

NOTE 1—Thermocouple  $T_1$  is used for better regulation of the temperature of the air in the furnace space.

NOTE 2—Ungrounded, metallic-sheathed thermocouples of 1-mm diameter have been found to meet the time constant requirements.

5.2 Specimen Holder—The specimen holder for solid specimens shall be as shown in Fig. 2.

5.2.1 Specimens in granular or powder form shall be contained in thin-wall, open-top vessels of inert materials whose outside dimensions conform to the specimen shape and maximum size specified in 6.1. These vessels shall have walls of either solid or mesh construction.

5.3 Specimen Location—During the test, the geometric center of the specimen shall be located at the geometric center  $\pm 3$  mm [ $\pm \frac{1}{8}$  in.] of the 76-mm [3-in.] diameter tube.

## 6. Test Specimens

6.1 All test specimens shall be 38 by 38 by 51  $\pm$  2.5 mm [1.5 by 1.5 by 2.0  $\pm$  0.1 in.]. The specimens shall be dried at 60  $\pm$  3°C [140  $\pm$  5°F] for not less than 24 h but no more than 48 h. Specimens shall then be placed in a desiccator to cool at least 1 h before testing.

6.2 Not less than four identical specimens shall be tested.

## 7. Procedure

### 7.1 Furnace Preparation:

7.1.1 Conduct the test at room conditions of 21  $\pm$  3°C [70  $\pm$  5°F].

7.1.2 Air Flow—Provide an external air source to supply clean air through a metal tube located near the furnace top, tangentially between the annular spaced ceramic tubes. The air shall be supplied at a steady and controllable rate of 0.0027 m<sup>3</sup>/min [0.10 ft<sup>3</sup>/min]  $\pm$  20 %, which will give an air flow of 3 m [10 ft]/min past a loaded specimen in the furnace at 750°C

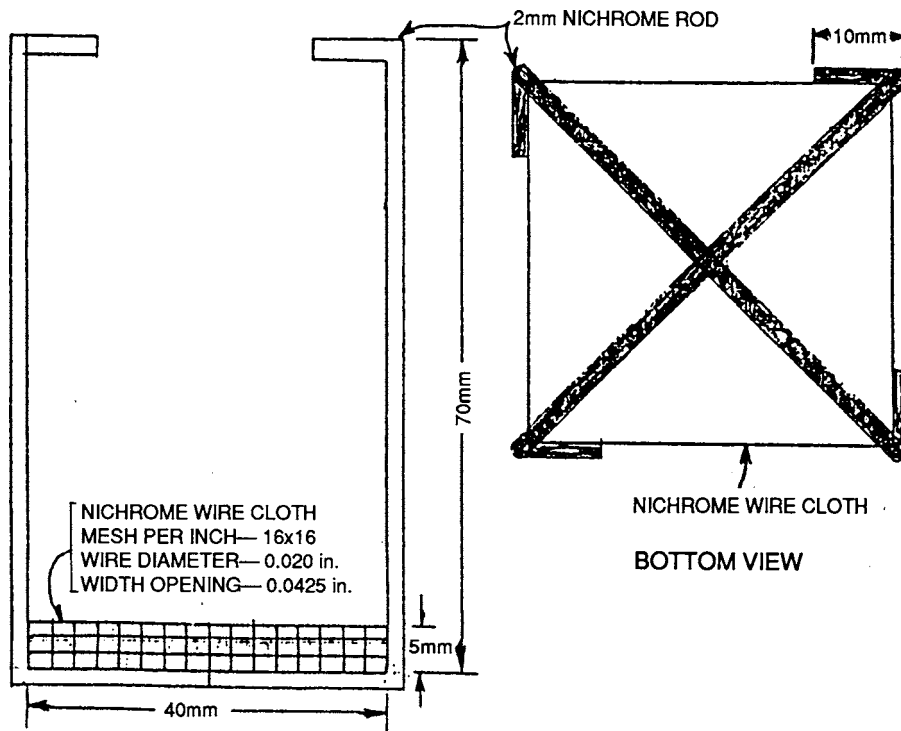

**FIG. 2 Specimen Holder for Solid Specimens**

[1382°F]. Measure the air at room temperature, as specified in 7.1.1 and meter by a rotameter or other metering device in line with the metal tube.

7.1.3 Prepare the furnace by bringing the temperature of thermocouple  $T_2$  (Note 3), located in the furnace at the position to be occupied by the geometric center of the specimen, to a temperature of  $750 \pm 5.5^\circ\text{C}$  [ $1382 \pm 10^\circ\text{F}$ ]. Maintain the temperature in the unloaded furnace for at least 15 min to assure stability.

NOTE 3—The temperature  $T_2$  is measured by means of a thermocouple inserted from the top during the initial heating period. Once the operating temperature has been established by thermocouple  $T_2$ , note the temperature on thermocouple  $T_1$  and control the test chamber during the test to the observed  $T_1$  temperature reading.  $T_3$  may be used as  $T_2$ .

7.2 As rapidly as possible, insert the test specimen into the furnace with thermocouple  $T_3$  inserted from the top of the specimen to its approximate geometric center and thermocouple  $T_4$  attached to the side surface of the specimen. Close the top cover to the  $6.4\text{-cm}^2$  [ $1\text{-in.}^2$ ] opening immediately after insertion of the specimen. Readings for thermocouples  $T_3$  and  $T_4$  shall be made at intervals (Note 4) not to exceed 10 s during the first 5 min, and as often as necessary afterwards to produce a smooth curve. Do not change the regulation of the current through the heating coils and the air flow during the test.

NOTE 4—A continuous read-out recording is preferred since it is possible for the maximum temperature to occur between the 10-s intervals.

7.3 Continue the test until the temperatures at thermocouples  $T_3$  and  $T_4$  have reached maxima, or until it is clearly evident that the specimen does not pass this test.

7.3.1 After 30 minutes of testing have elapsed, or at any time subsequent to that, testing shall be discontinued if, over the previous 10 minutes, the temperature measured at the center thermocouple  $T_3$  has risen by no more than  $1^\circ\text{C}$  in any one minute. The final temperature reading shall be recorded as the maximum temperature.

7.4 Throughout the test make and record visual observations on the specimens, noting quality, quantity, or intensity and duration of flaming or smoking, or both, and change of state.

7.5 Weigh each specimen before and after testing and record the weight loss to the nearest 1 %.

## 8. Report

8.1 Report the material as passing the test if at least three of the four specimens tested meet the individual specimen criteria detailed in 8.2 or 8.3. The three specimens do not need to meet the same condition.

8.2 When the weight loss of the specimen is 50 % or less:

8.2.1 The recorded temperatures of the surface and interior thermocouples do not at anytime during the test rise more than  $30^\circ\text{C}$  [ $54^\circ\text{F}$ ] above the stabilized temperature measured at  $T_2$  prior to the test.

8.2.2 There is no flaming from the specimen after the first 30 s.

8.3 When the weight loss of the specimen exceeds 50%:

8.3.1 The recorded temperature of the surface and interior thermocouples do not at anytime during the test rise above the stabilized temperature measured at  $T_2$  prior to the test.

8.3.2 There is no flaming from the specimen at any time during the test.

## 9. Precision and Bias

9.1 No information is presented about the precision and bias of this test method for measuring combustion characteristics since the test results are nonquantitative. (See X1.7.)

## 10. Keywords

10.1 building materials; combustion; heated tube; limited combustion; Setchkin furnace; vertical tube furnace

## APPENDIX

### (Nonmandatory Information)

#### X1. COMMENTARY

##### X1.1 Introduction

X1.1.1 The difference in fire risk between a combustible building material and a noncombustible (or incombustible) one is generally obvious. However, some materials may contain only a limited amount of combustible content and may not contribute appreciably to an ambient fire. The term noncombustible, while in recognized use as indicating a material that will not ignite or burn, is indefinite in its application unless referenced to a well defined testing procedure.

##### X1.2 Definition

X1.2.1 Most dictionaries have defined noncombustible in simple terms, such as that used in the 1920 edition of the National Building Code promulgated by the National Board of Fire Underwriters (NBFU): Incombustible materials or construction are those that “will not ignite or burn when subjected to fire.” In 1943 the same code redefined incombustible construction as “assemblies which do not involve materials of such kind or quantity or so contained as to burn during exposure in a test fire or continue flaming or ignite after the furnace is shut off.”

X1.2.2 About this same time Committee C05 (now E05) and the New York City Building Code suggested adding a reference of 649°C [1200°F] as the fire exposure temperature. By 1949 the term incombustible was changed to noncombustible in the National Building Code without definition. The first edition of the BOCA Basic Building Code (1950) defined a noncombustible material as “any material which will neither ignite or actively support combustion in air at a temperature of 649°C [1200°F] during an exposure of five minutes in a vented tube or vented crucible furnace.”

X1.2.3 The 1955 edition of the NBFU National Building Code established a definition for noncombustible material (1)<sup>4</sup> that was subsequently adopted by other model codes, the Life Safety Code (2), and most local codes. The adopted definition was as follows:

Noncombustible as applied to a building construction material means a material that, in the form in which it is used, falls in one of the following groups (a) through (c). It does not apply to surface finish materials nor to the determination of whether a material is noncombustible from the standpoint of clearances to heating appliances, flues or other sources of high tempera-

ture. No material shall be classed as noncombustible which is subject to increase in combustibility or flame spread rating beyond the limits herein established, through the effects of age, moisture or other atmospheric condition. Flame spread rating as used herein refers to ratings obtained in accordance with Test Method E 84.

a) Materials no part of which will ignite and burn when subjected to fire. Any material that liberates flammable gas when heated to a temperature of 750°C [1382°F], for 5 min shall not be considered noncombustible within the meaning of this paragraph.

b) Materials having a structural base of noncombustible material, as defined in (a), with a surfacing not over 1/8-in. thick that has a flame spread rating not higher than 50.

c) Materials, other than as described in (a) or (b), having a surface flame spread rating not higher than 25 without evidence of continued progressive combustion and of such composition that surfaces that would be exposed by cutting through the material in any way would not have a flame spread rating higher than 25 without evidence of continued progressive combustion.

X1.2.4 In adopting this definition, NBFU stated that it was based on a determination of which materials “could be properly classed as noncombustible and then fixing the qualifying conditions in the definition to include these materials.” The definition was considered to apply to materials used for the walls, roofs, or other structural parts of buildings, but not to surface finish materials and not to the determination of whether a material is noncombustible from the standpoint of clearances to heating appliances, flues, or other sources of high temperature.

X1.2.5 After Test Method E 136 was promulgated, (initially as a tentative in 1958, then as a full standard in 1965), many building codes replaced either part (a) of the NBFU definition or the entire definition with the specification that materials shall have been successfully tested in accordance with Test Method E 136. In 1973, the American Insurance Association (successor to NBFU) introduced a definition of a limited-combustible material and redefined a noncombustible material as one that, in the form in which it is used and under the conditions anticipated, will not ignite, burn, support combustion, or release flammable vapors, when subjected to fire or heat.

X1.2.6 To avoid misinterpretation in the use of the term noncombustible, Committee E05 has decided to limit the use of this term, and it was eliminated from the title and text of Test

<sup>4</sup> The boldface numbers in parentheses refer to the list of references appended to this method.

Method E 136 in 1979. The current title provides a more specific description of the restricted nature of the test method.

### X1.3 Origin and Early History of Test Method E 136

X1.3.1 In 1912 R. E. Prince developed a furnace apparatus to study the ignitability of various wood species and investigate the effect of fire-retardant chemical treatments on their ignition characteristics (3, 4). This apparatus as shown in Fig. X1.1 consisted essentially of a quartz cylinder 76 mm [3 in.] in diameter and 254 mm [10 in.] long, which was wound with a high electrical resistance nichrome ribbon. The cylinder was heavily insulated with asbestos. A lower chamber of about 89 mm [3.5 in.] in diameter and 203 mm [8 in.] deep formed a continuation of the upper chamber. A natural draft was used. No attempt was made to control the temperature or humidity of the air passing through the apparatus. The test temperature was 200°C [392°F]. The 32 by 32 by 102-mm [1¼ by 1¼ by 4-in.] specimen was first weighted and then lowered in the hot quartz cylinder where it remained until it ignited or for 40 min. Ignition time, if it occurred, was recorded and the specimen was then moved into the lower cooler chamber and allowed to burn for not more than 3 min. Loss of weight was then determined. Intensity of burning was also recorded.

X1.3.2 An apparatus quite similar to the Prince-FPL apparatus was later adopted as part of the British Standard 476-1932. In a revision of BS 476 in 1953, the test was renamed, and the furnace was preheated and maintained at 750°C [1382°F] prior to introduction of the specimen. This test specified that a material shall be considered combustible if,

during the 15-min test period, any one of six specimens was observed to flame, to produce vapors that were ignited by a pilot flame, or to cause the temperature of the furnace to increase 50°C or more above 750°C [1382°F]. In a report dated April 11, 1945, Dr. S. H. Ingberg suggested to Committee C05 (now E05) a method of test quite similar to the British test. The apparatus is shown in Fig. X1.2. A paper describing the test was published in the ASTM proceedings (5, 6). The method differed from the British test by having the insulation enclosure round instead of square and employed a constant temperature of 750°C [1382°F] instead of a graduated temperature. Specimen size was 50 by 38 mm [2 by 1½ in.] by  $T$  where  $T$  equals the normal thickness or a maximum of 38 mm [1½ in.].

X1.3.3 A variation of the 1945 proposed apparatus and a method for determining the ignition temperature of plastics under well controlled conditions was reported by N. P. Setchkin in December 1949 (7). This apparatus is shown in Fig. X1.3. This test was subsequently adopted by Committee D20 as Test Method D 1929.<sup>5</sup> Major changes included elimination of the lower chamber, the provision of two concentric refractory cylinders and a controlled air flow directed between the cylinders, and the location of thermocouples.

X1.3.4 At the request of Subcommittee V (Nomenclature and Definitions) of Committee E05, tests on 47 specimens of solid materials were made in 1952 at the National Bureau of Standards (NBS), the National Research Council of Canada,

<sup>5</sup> Published as Test Method D 1929 - 62 T, that is, a tentative standard.

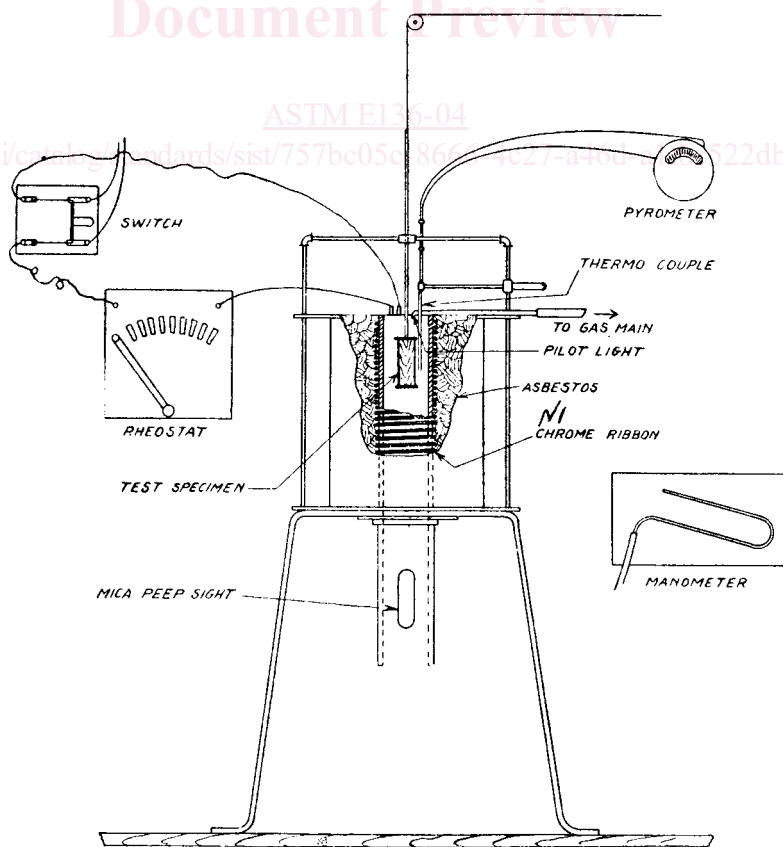

FIG. X1.1 Inflammability Apparatus No. 1

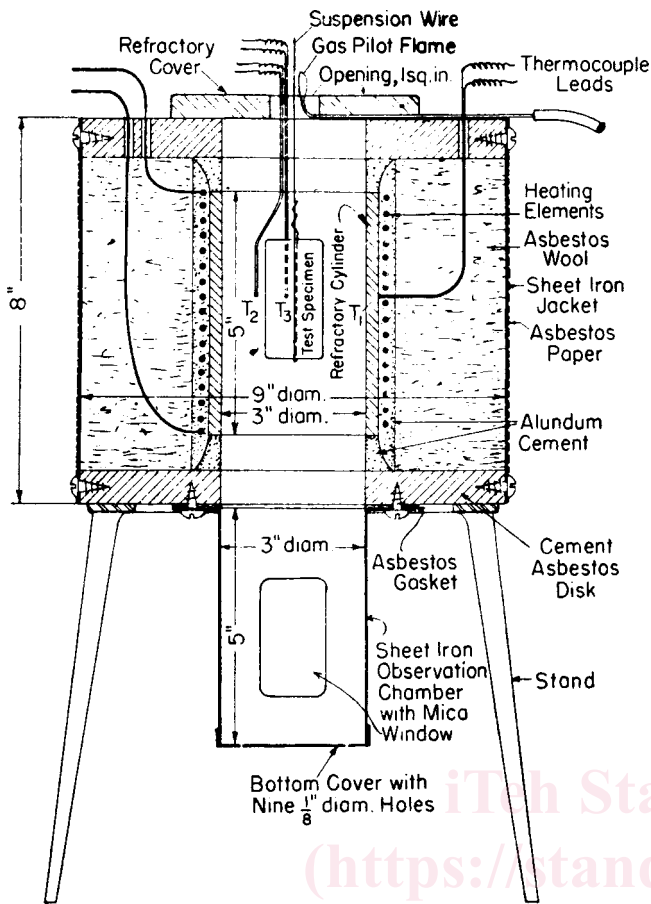
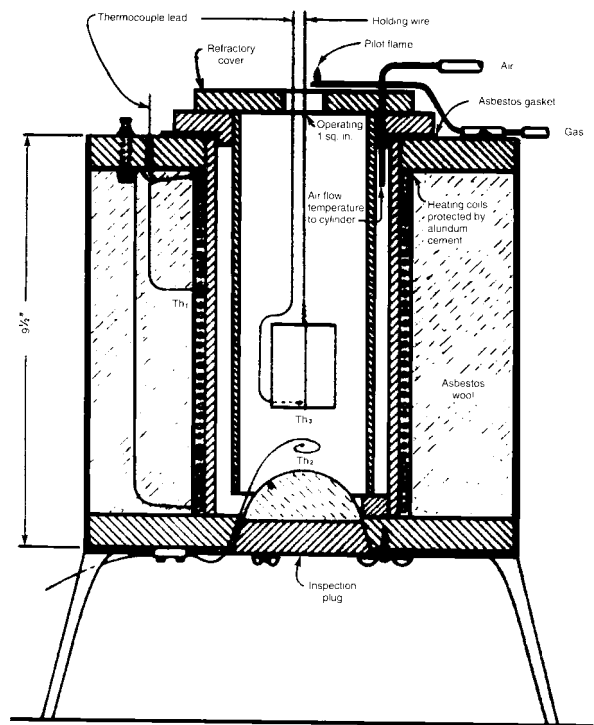

FIG. X1.2 Apparatus for Incombustibility Tests



NOTE—  
Legend:  
Th<sub>1</sub>—Thermocouple on outer wall  
Th<sub>2</sub>—Thermocouple in air stream  
Th<sub>3</sub>—Thermocouple in or on the specimen

FIG. X1.3 Ignition Apparatus for Solids

The Ohio State University, Southwest Research Institute, and Owens-Corning Laboratories for the purpose of evaluating a technique for determining the combustibility classifications of solid materials (8, 9). Professor Shank, at The Ohio State University, continued work on the test method. Through his efforts publication of a revised draft of the proposed test in the *ASTM Bulletin* was authorized at the February 8, 1957, meeting of Committee E05. Publication was for information purposes and comment (10).

X1.3.5 It was reported at the February 12, 1958, meeting of Committee E05 that no comments or criticisms had been received on the test method; a motion to publish it as a tentative test method was carried (11). The apparatus described in Tentative Standard Method of Test for Defining Noncombustibility of Building Materials<sup>6</sup> was as shown in Fig. X1.4. Committee E05 voted for retention of the standard following its October 1963 meeting and at the same meeting voted to advance Test Method E 136 to full standard that was published in 1965.<sup>7</sup> Additional changes, described in X1.5 through X1.8, were incorporated in the 1973 and 1979 revisions of the test method.

<sup>6</sup> This test method was approved June 22, 1958, and published as E 136 - 58 T, that is, a tentative standard.

<sup>7</sup> Method of Test E 136 - 65, Determining Noncombustibility of Elementary Materials.

### X1.4 Other Test Methods

X1.4.1 At the request of the U.S. Coast Guard (June 3, 1970), a test program at the NBS was coordinated by a task subgroup of Subcommittee E05.05 to evaluate two principal tests used to determine combustibility: Test Method E 136 and ISO R 1182 (12). A modification of ISO 1182 was adopted in 1973 by the Intergovernmental Maritime Consultative Organization (IMCO), an agency of the United Nations, for qualifying marine materials as noncombustible. This test is designated Resolution A270 (VIII) and incorporates changes in equipment details plus requirements for approval as noncombustible materials; in this test method, the average duration of flaming is limited to 10 s. This test method was adopted in 1976 as the U.S. Coast Guard test for approval of noncombustible materials for merchant vessels. ISO R 1182-1970 was superseded by ISO 1182-1979 using the apparatus shown in Fig. X1.5. The current version contains improved test method and equipment details and recognition of mass loss for low density polymeric materials. Furthermore, materials are no longer classified as noncombustible; instead, the following (average) test results are reported: (1) maximum readings of the furnace, surface, and center thermocouples; (2) duration of sustained flaming; and (3) mass loss. The annex in ISO R 1182 provides "suggested criteria for evaluation: not more than 50°C rise; not more than 20 s flaming; and not more than 50 % mass loss."