



**SLOVENSKI STANDARD**  
**oSIST prEN 1793-1:2010**  
**01-september-2010**

---

**Protihrupne ovire za cestni promet - Preskusna metoda za ugotavljanje akustičnih lastnosti - 1. del: Karakteristike, značilne za absorpcijo zvoka**

Road traffic noise reducing devices - Test method for determining the acoustic performance - Part 1: Intrinsic characteristics of sound absorption

Lärmschutzeinrichtungen an Straßen - Prüfverfahren zur Bestimmung der akustischen Eigenschaften - Teil 1: Produktspezifische Merkmale der Schallabsorption

Dispositifs de réduction du bruit du trafic routier - Méthode d'essai pour la détermination de la performance acoustique - Partie 1: Caractéristiques intrinsèques de l'absorption acoustique

**Ta slovenski standard je istoveten z: prEN 1793-1**

---

**ICS:**

|           |                                     |                                     |
|-----------|-------------------------------------|-------------------------------------|
| 17.140.30 | Emisija hrupa transportnih sredstev | Noise emitted by means of transport |
| 93.080.30 | Cestna oprema in pomožne naprave    | Road equipment and installations    |

**oSIST prEN 1793-1:2010**

**en,fr,de**



EUROPEAN STANDARD  
NORME EUROPÉENNE  
EUROPÄISCHE NORM

**DRAFT**  
**prEN 1793-1**

June 2010

ICS 17.140.30; 93.080.30

Will supersede EN 1793-1:1997

English Version

## Road traffic noise reducing devices - Test method for determining the acoustic performance - Part 1: Intrinsic characteristics of sound absorption

Dispositifs de réduction du bruit du trafic routier - Méthode d'essai pour la détermination de la performance acoustique  
- Partie 1: Caractéristiques intrinsèques de l'absorption acoustique

Lärmschutzeinrichtungen an Straßen - Prüfverfahren zur Bestimmung der akustischen Eigenschaften - Teil 1: Produktspezifische Merkmale der Schallabsorption

This draft European Standard is submitted to CEN members for enquiry. It has been drawn up by the Technical Committee CEN/TC 226.

If this draft becomes a European Standard, CEN members are bound to comply with the CEN/CENELEC Internal Regulations which stipulate the conditions for giving this European Standard the status of a national standard without any alteration.

This draft European Standard was established by CEN in three official versions (English, French, German). A version in any other language made by translation under the responsibility of a CEN member into its own language and notified to the CEN Management Centre has the same status as the official versions.

CEN members are the national standards bodies of Austria, Belgium, Bulgaria, Croatia, Cyprus, Czech Republic, Denmark, Estonia, Finland, France, Germany, Greece, Hungary, Iceland, Ireland, Italy, Latvia, Lithuania, Luxembourg, Malta, Netherlands, Norway, Poland, Portugal, Romania, Slovakia, Slovenia, Spain, Sweden, Switzerland and United Kingdom.

Recipients of this draft are invited to submit, with their comments, notification of any relevant patent rights of which they are aware and to provide supporting documentation.

**Warning** : This document is not a European Standard. It is distributed for review and comments. It is subject to change without notice and shall not be referred to as a European Standard.



EUROPEAN COMMITTEE FOR STANDARDIZATION  
COMITÉ EUROPÉEN DE NORMALISATION  
EUROPÄISCHES KOMITEE FÜR NORMUNG

**Management Centre: Avenue Marnix 17, B-1000 Brussels**

## Contents

|   | Page |
|---|------|
| Foreword .....  | 3    |
| Introduction .....  | 4    |
| 1 Scope .....   | 5    |
| 2 Normative references .....  | 5    |
| 3 Symbols .....   | 5    |
| 4 Test arrangement.....   | 6    |
| 5 Test procedure and evaluation .....   | 7    |
| 6 Test report .....   | 8    |
| Annex A (normative) Categorization of single-number rating .....                    | 9    |
| Annex B (informative) Guidance note on use of the number rating $DL_{\alpha}$ ..... | 10   |

iTeh STANDARD PREVIEW  
(standards.iteh.ai)

SIST EN 1793-1:2013

<https://standards.iteh.ai/catalog/standards/sist/9a1499d0-bdf0-4926-bd29-a5b9a6c7dd76/sist-en-1793-1-2013>

## Foreword

This document (prEN 1793-1:2010) has been prepared by Technical Committee CEN/TC 226 "Road equipment", the secretariat of which is held by AFNOR.

This document is currently submitted to the CEN Enquiry.

This document will supersede EN 1793-1:1997.

It should be read in conjunction with:

*prEN 1793-2 Rev, Road traffic noise reducing devices - Test method for determining the acoustic performance - Part 2 : Intrinsic characteristics of airborne sound insulation for diffuse sound fields*

*EN 1793-3:1998, Road traffic noise reducing devices - Test method for determining the acoustic performance – Part 3: Normalized traffic noise spectrum*

*CEN/TS 1793-4, Road traffic noise reducing devices - Test method for determining the acoustic performance – Part 4: Intrinsic characteristics – In situ values of sound diffraction*

*CEN/TS 1793-5, Road traffic noise reducing devices - Test method for determining the acoustic performance – Part 5: Intrinsic characteristics – In situ values of sound reflection under direct sound field conditions*

*prEN 1793-6, Road traffic noise reducing devices - Test method for determining the acoustic performance – Part 6: Intrinsic characteristics – In situ values of airborne sound insulation under direct sound field conditions*

## Introduction

Where a sound reflecting surface is installed along a road it may be effective to use sound absorbing devices on its traffic side to reduce additional noise nuisance caused by reflected sound. This treatment may be needed in the presence of the following:

- noise barriers, rocks or retaining walls that can reflect sound waves toward unprotected areas,
- vertical cuttings or reflective surfaces that face each other,
- tunnels and their approaches,
- traffic passing close to a barrier where reflections between the vehicles and the barrier may reduce effectiveness.

This European Standard specifies a test method for qualifying the sound absorption performance of noise reducing devices designed for roads (a measure of intrinsic performance). It is not concerned with determining *in-situ* performance (extrinsic performance) which additionally depends on factors which are not related to the product itself, e.g. the dimensions of the barrier and quality of installation work and site factors such as ground impedance, site geometry etc. The test is designed to allow the intrinsic sound absorption performance of the device to be measured and the resulting rating should aid the selection of devices for particular roadside applications.

NOTE This method may be used to qualify noise reducing devices for other applications, e.g. found along railways or near industrial sites. In these cases the single-number ratings should be calculated using an appropriate spectrum.

[SIST EN 1793-1:2013](https://standards.iteh.ai/catalog/standards/sist/9a1499d0-bdf0-4926-bd29-a5b9a6c7dd76/sist-en-1793-1-2013)

<https://standards.iteh.ai/catalog/standards/sist/9a1499d0-bdf0-4926-bd29-a5b9a6c7dd76/sist-en-1793-1-2013>

## 1 Scope

This European Standard specifies the laboratory method for measuring the sound absorption of flat noise barriers or flat cladding for retaining walls or tunnels. It covers the assessment of the intrinsic sound absorption performance of roadside noise reducing devices which can reasonably be assembled inside the testing facility described in EN ISO 354.

The test method in EN ISO 354, referred to in this standard, is strictly valid only for plane absorbers and in particular excludes devices which act as weakly damped resonators. Some devices will depart significantly from these requirements and in these cases care is needed in interpreting the results.

NOTE 1 The test method in EN ISO 354 is based on measurements in a reverberation room where diffuse sound field conditions prevail. As a uniformly applicable method for the determination of the sound absorptive performance of noise reducing devices under free field conditions is still under development, the measurement results according to this European Standard are temporarily considered relevant for application on noise reducing devices in reverberant as well as in free field conditions.

When the method for free field conditions will be available, it will then replace the method described in the present European standard for products to be installed in free field conditions (target schedule as from today: 2013).

NOTE 2 In the previous version of this European Standard dated September 1997 the basic test method was derived from EN 20354: 1985. In the current version of this European Standard the basic test method is derived from EN ISO 354: 2003. In the current version of the basic test method an essential change was introduced compared to the previous version, viz. the application of a correction method for changes in sound attenuation in air caused by changes in air temperature and humidity during the test. Because this correction was not applied in the previous version of the test method the results from the current version may deviate considerably from the results obtained with the previous version of the method. Specifically for test samples with a high absorption coefficient these changes may amount to 1 or 2 dB for the single number rating  $DL_{\alpha}$ , either in a positive or a negative sense. The effect of the application of the correction will be most noticeable in the higher frequency bands. To avoid possible confusion between the old and the new measurement results the continued use of measurement results obtained with the previous version of this European Standard (dated September 1997) is not recommended.

## 2 Normative references

The following referenced documents are indispensable for the application of this document. For dated references, only the edition cited applies. For undated references, the latest edition of the referenced document (including any amendments) applies.

EN 1793-3, 1997, Road traffic noise reducing devices - Test method for determining the acoustic performance - Part 3 : Normalized traffic noise spectrum

EN ISO 354, Acoustics - Measurement of sound absorption in a reverberation room (ISO 354:2003)

## 3 Symbols

For the purposes of this standard, the following symbols apply:

|               |   |
|---------------|---|
| $\alpha_{si}$ | Sound absorption coefficient in the $i^{\text{th}}$ one-third octave band   |
| $L_i$         | Normalized A-weighted sound pressure level, in decibels, of traffic noise in the $i^{\text{th}}$ one-third octave band defined in EN 1793-3 |

## prEN 1793-1:2010 (E)

|               |   |
|---------------|---|
| $DL_{\alpha}$ | Single-number rating of sound absorption performance expressed as a difference of A-weighted sound pressure levels, in decibels |
|---------------|---|

#### 4 Test arrangement

The test arrangement shall be as described in EN ISO 354 with the following modifications:

- The test specimen shall be assembled in the test chamber in the same manner as the manufactured device, with the same connections and seals between component parts;
- All the reflecting parts exposed on the traffic side of the material (posts, brackets and other parts) shall be present on the specimen as in practice;
- Where posts are employed in construction, at least one post shall be included in the specimen with panels attached on both sides. The length of the panels on one side of the post shall be  $\geq 2$  m (see Figure 1). The side that would face the traffic shall face the inner part of the room;
- For testing barriers, the specimen shall be placed directly against one of the surfaces (floor, wall or ceiling) of the chamber, without air gaps. If the use of posts according to the instruction given above would introduce an air gap between the back of the noise barrier elements and the surface of the room, modifications shall be made to the posts to ensure that the back of the noise barrier elements is placed directly against the room surface;
- For testing absorptive cladding for use on retained cuttings, tunnel walls and other reflective surfaces the specimen shall be mounted against one of the surfaces of the chamber leaving the same air gap as proposed for the actual construction. In these conditions, the distance between the back of the sample and the surface of the chamber shall be clearly reported.

SIST EN 1793-1:2013

<https://standards.iteh.ai/catalog/standards/sist/9a1499d0-bdf0-4926-bd29-a5b9a6c7dd76/sist-en-1793-1-2013>

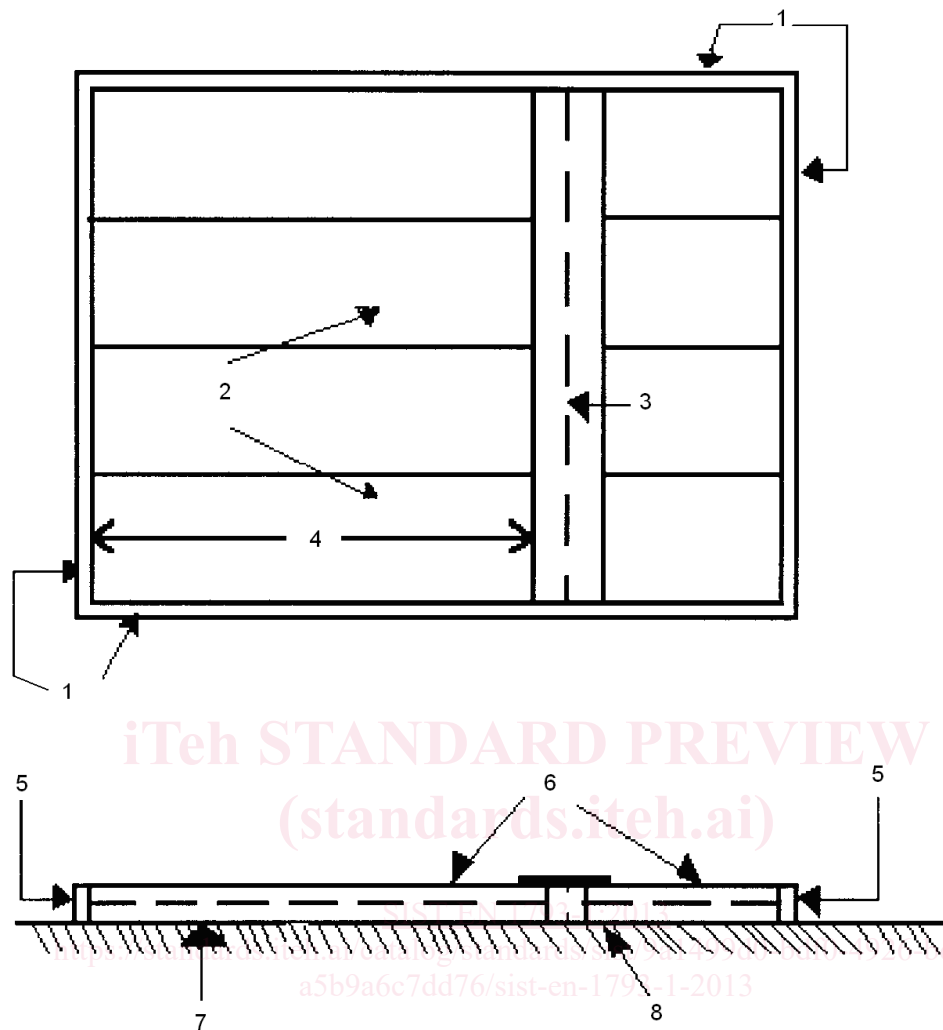

**Key:**

|   |                                |   |  |
|---|--------------------------------|---|--|
| 1 | Reflective frame               | 5 | Reflective frame sealed against sample |
| 2 | Panels (sealed as in practice) | 6 | Panels                                 |
| 3 | Post                           | 7 | Chamber surface (floor)                |
| 4 | $L \geq 2 \text{ m}$           | 8 | Post (sealed as in practice)           |

**Figure 1 - Illustration of post arrangement****5 Test procedure and evaluation****5.1 Test method**

The sound absorption coefficients  $\alpha_{Sj}$  in each one-third octave band in the range 100 Hz to 5 kHz shall be determined using the method described in EN ISO 354.

## prEN 1793-1:2010 (E)

**5.2 Single-number rating of sound absorption  $DL_\alpha$** 

A single-number rating shall be derived to indicate the performance of the product. The individual sound absorption coefficients shall be weighted according to the normalized traffic noise spectrum defined in EN 1793-3.

The single-number rating of sound absorption  $DL_\alpha$ , in decibels, is given by:

$$DL_\alpha = -10 \lg \left| 1 - \frac{\sum_{i=1}^{18} \alpha_{si} 10^{0.1 L_i}}{\sum_{i=1}^{18} 10^{0.1 L_i}} \right|$$

In some cases the ratio of the summations term in the expression of  $DL_\alpha$  can exceed 1 which precludes the calculation of  $DL_\alpha$ . For this reason the maximum value of this ratio shall be limited to 0,99.

NOTE Annex B provides guidance on the use of the single-number rating.

**6 Test report****6.1 Expression of results**

The one-third octave band values of the sound absorption coefficients  $\alpha_{Si}$  shall be given at all frequencies of measurement in tabular form and in the form of a graph. The coefficients shall be rounded to the nearest second decimal place.

The single-number rating of sound absorption  $DL_\alpha$  shall be reported after being rounded to the nearest integer.

If the absorption performance is to be categorized then this shall be in accordance with annex A.

**6.2 Further information**

The test report shall include the information listed below:

- a) reference to this European Standard;
- b) name and address of testing organisation;
- c) date of the test;
- d) a description of test conditions including mounting position (floor, wall or ceiling), procedures and equipment used in accordance with EN ISO 354 ;
- e) a full description of the test specimen including manufacturer's name and product identifier with sectional drawings and photographs showing mounting conditions ; masses, densities, dimensions and specifications of panels, posts and seals, including any internal components, shall be given ;
- f) the name and address of the organization which performed the measurements.
- g) signature of the person responsible for the measurements.