



Designation: F363 – 99 (Reapproved 2004)

Standard Test Method for Corrosion Testing of Gaskets¹

This standard is issued under the fixed designation F363; the number immediately following the designation indicates the year of original adoption or, in the case of revision, the year of last revision. A number in parentheses indicates the year of last reapproval. A superscript epsilon (ϵ) indicates an editorial change since the last revision or reapproval.

1. Scope

1.1 This test method covers the evaluation of gaskets under corrosive conditions at varying temperature and pressure levels. The test unit may be glass lined if the flanges are sufficiently plane (industry accepted), thus providing resistance to all chemicals, except hydrofluoric acid, from cryogenic temperatures to 260°C (500°F) at pressures from full vacuum to the allowable pressure rating of the unit, or made of other suitable material. The test unit described (Fig. 1) has an internal design pressure rating of 1034 kPa (150 psi) at 260°C (500°F).

1.2 The values stated in SI units are to be regarded as the standard.

1.3 *This standard does not purport to address all of the safety concerns, if any, associated with its use. It is the responsibility of the user of this standard to establish appropriate safety and health practices and determine the applicability of regulatory limitations prior to use.* For specific hazards statements, see Section 5.

2. Referenced Documents

2.1 *ASTM Standards:*²

F112 Test Method for Sealability of Enveloped Gaskets

2.2 *ASME Standards:*³

B16.21 Nonmetallic Gaskets for Pipe Flanges

2.3 *ASTM Adjuncts:*⁴

Leakage Test Unit

3. Significance and Use

3.1 This test method is designed to compare all types of gaskets under simulated field operating conditions. Performance of a gasket can thus be measured prior to the start-up of

¹ This test method is under the jurisdiction of ASTM Committee F03 on Gaskets and is the direct responsibility of Subcommittee F03.40 on Chemical Test Methods.

Current edition approved April 1, 2004. Published April 2004. Originally approved in 1973. Last previous edition approved in 1999 as F363 – 99. DOI: 10.1520/F0363-99R04.

² For referenced ASTM standards, visit the ASTM website, www.astm.org, or contact ASTM Customer Service at service@astm.org. For *Annual Book of ASTM Standards* volume information, refer to the standard's Document Summary page on the ASTM website.

³ Available from American Society of Mechanical Engineers (ASME), ASME International Headquarters, Three Park Ave., New York, NY 10016-5990.

⁴ Available from ASTM International Headquarters. Order Adjunct No. ADJF0363.

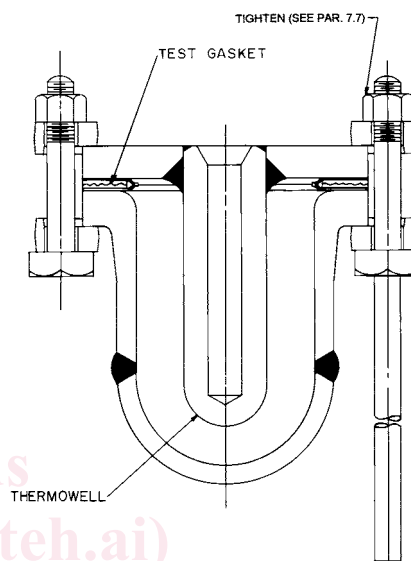

FIG. 1 Test Unit

chemical processes.⁵ The design of the test unit provides maximum range of corrosion resistance so that meaningful results are possible. This test method may be used as a routine test when agreed upon between the purchaser and the seller.

4. Apparatus

4.1 *Corrosion Test Unit*—The unit⁶ shall contain a suitable thermowell, strategically placed near the center so that correct temperature readings may be made. The gasket seating size shall be such as to accommodate a standard 102-mm (4-in.) size gasket.

4.2 *Heat Source*—A 3-A (660-W, 220-V) electric heater has been found to be satisfactory to heat the unit in the vertical position to 232°C (450°F). If the unit is to be tested horizontally, the fixture should be in a suitable environmental chamber or oven capable of attaining the desired temperatures.

⁵ Supporting data have been filed at ASTM International Headquarters and may be obtained by requesting Research Report F03-1002.

⁶ The sole source of supply of the apparatus known to the committee at this time is The Pfadler Co., P.O. Box 23600, Rochester, NY 14692. If you are aware of alternative suppliers, please provide this information to ASTM International Headquarters. Your comments will receive careful consideration at a meeting of the responsible technical committee¹, which you may attend.