



Designation: A 703/A 703M – 04

## Standard Specification for Steel Castings, General Requirements, for Pressure- Containing Parts<sup>1</sup>

This standard is issued under the fixed designation A 703/A 703M; the number immediately following the designation indicates the year of original adoption or, in the case of revision, the year of last revision. A number in parentheses indicates the year of last reapproval. A superscript epsilon (ε) indicates an editorial change since the last revision or reapproval.

### 1. Scope\*

1.1 This specification<sup>2</sup> covers a group of common requirements that, unless otherwise specified in an individual specification, shall apply to steel castings for pressure-containing parts under each of the following ASTM specifications:

Title of Specification	ASTM Designation
Steel Castings, Carbon, Suitable for Fusion Welding for High-Temperature Service	A 216/A 216M
Steel Castings, Martensitic Stainless and Alloy, for Pressure-Containing Parts Suitable for High-Temperature Service	A 217/A 217M
Steel Castings, Austenitic, for High-Temperature Service	A 351/A 351M
Steel Castings, Ferritic and Martensitic, for Pressure-Containing Parts Suitable for Low-Temperature Service	A 352/A 352M
Steel Castings, Alloy, Specially Heat-Treated, for Pressure-Containing Parts, Suitable for High-Temperature Service	A 389/A 389M
Steel Castings Suitable for Pressure Service	A 487/A 487M

1.2 This specification also covers a group of supplementary requirements which may be applied to the above specifications as indicated therein. These are provided for use when additional testing or inspection is desired and apply only when specified individually by the purchaser in the order.

1.3 In case of conflict between the requirements of the individual specification and this general specification, the former shall prevail.

1.4 The values stated in either inch-pound units or SI units are to be regarded separately as standard. Within the text, the SI units are shown in brackets. The values stated in each system are not exact equivalents; therefore, each system must be used independently of the other. Combining values from the two systems may result in nonconformance with the specification. Inch-pound units are applicable for material ordered to Specification A 703 and SI units for material ordered to Specification A 703M.

<sup>1</sup> This specification is under the jurisdiction of ASTM Committee A01 on Steel, Stainless Steel and Related Alloys and is the direct responsibility of Subcommittee A01.18 on Castings.

Current edition approved April 1, 2004. Published May 2004. Originally approved in 1974. Last previous edition approved in 2003 as A 703/A 703M – 03.

<sup>2</sup> For ASME Boiler and Pressure Vessel Code applications see related Specification SA-703/SA-703M in Section II of that Code.

### 2. Referenced Documents

#### 2.1 ASTM Standards:<sup>3</sup>

- A 216/A 216M Specification for Steel Castings, Carbon, Suitable for Fusion Welding, for High-Temperature Service
- A 217/A 217M Specification for Steel Castings, Martensitic Stainless and Alloy, for Pressure-Containing Parts Suitable for High-Temperature Service
- A 351/A 351M Specification for Castings, Austenitic, Austenitic-Ferritic (Duplex), for Pressure-Containing Parts
- A 352/A 352M Specification for Steel Castings, Ferritic and Martensitic, for Pressure-Containing Parts, Suitable for Low-Temperature Service
- A 370 Test Methods and Definitions for Mechanical Testing of Steel Products
- A 380 Practice for Cleaning, Descaling, and Passivation of Stainless Steel Parts, Equipment, and Systems
- A 389/A 389M Specification for Steel Castings, Alloy, Specially Heat-Treated, for Pressure-Containing Parts, Suitable for High-Temperature Service
- A 487/A 487M Specification for Steel Castings Suitable for Pressure Service
- A 488/A 488M Practice for Steel Castings, Welding, Qualifications of Procedures and Personnel
- A 609/A 609M Practice for Castings, Carbon, Low-Alloy, and Martensitic Stainless Steel, Ultrasonic Examination Thereof
- A 751 Test Methods, Practices, and Terminology for Chemical Analysis of Steel Products
- A 800/A 800M Practice for Steel Casting, Austenitic Alloy, Estimating Ferrite Content Thereof
- A 802/A 802M Practice for Steel Castings, Surface Acceptance Standards, Visual Examination
- A 903/A 903M Specification for Steel Castings, Surface Acceptance Standards, Magnetic Particle and Liquid Penetrant Inspection

<sup>3</sup> For referenced ASTM standards, visit the ASTM website, www.astm.org, or contact ASTM Customer Service at service@astm.org. For *Annual Book of ASTM Standards* volume information, refer to the standard's Document Summary page on the ASTM website.

\*A Summary of Changes section appears at the end of this standard.

- A 941 Terminology Relating to Steel, Stainless Steel, Related Alloys, and Ferroalloys
- A 967 Specification for Chemical Passivation Treatments for Stainless Steel Parts
- A 991/A 991M Test Method for Conducting Temperature Uniformity Surveys of Furnaces Used to Heat Treat Steel Products
- E 29 Practice for Using Significant Digits in Test Data to Determine Conformance With Specifications
- E 94 Guide for Radiographic Examination
- E 125 Reference Photographs for Magnetic Particle Indications on Ferrous Castings
- E 165 Test Method for Liquid Penetrant Examination
- E 186 Reference Radiographs for Heavy-Walled (2 to 4½-in. (51 to 114-mm)) Steel Castings
- E 208 Test Method for Conducting Drop-Weight Test to Determine Nil-Ductility Transition Temperature of Ferritic Steels
- E 280 Reference Radiographs for Heavy-Walled (4½ to 12-in. (114 to 305-mm)) Steel Castings
- E 340 Test Method for Macroetching Metals and Alloys
- E 446 Reference Radiographs for Steel Castings up to 2 in. (51 mm) in Thickness
- E 709 Guide for Magnetic Particle Examination

### 2.2 ANSI Standard:

B16.5 Steel Pipe Flanges and Flanged Fittings<sup>4</sup>

### 2.3 Standards of the Manufacturer's Standardization Society of the Valve and Fitting Industry:

MSS SP 53 Quality Standard for Steel Castings for Valves, Flanges and Fittings, and Other Piping Components (Dry Powder Magnetic Particle Inspection Method)<sup>5</sup>

MSS SP 54 Quality Standard for Steel Castings for Valves, Flanges and Fittings, and Other Piping Components (Radiographic Inspection Method)<sup>5</sup>

## 3. Terminology

### 3.1 Definitions:

3.1.1 The definitions in Test Methods and Definitions A 370 and Terminology A 941 are applicable to this specification and those listed in 1.1.

3.1.2 *chaplet, n*—a chaplet is a metallic support placed in a mold cavity to maintain the spacing between a core and the mold.

3.1.3 *electronic data interchange (EDI), n*—the computer-to-computer exchange of business information in a standard format such as ANSI ASC X12.

3.1.4 *heat, n*—all the molten metal poured from a single furnace or all the molten metal from two or more furnaces poured into a single ladle or casting prior to the replenishing of the furnace(s).

3.1.5 *internal chill, n*—an internal chill is a metallic device placed in a mold cavity to increase the rate of heat removal at that location.

## 4. Materials and Manufacture

4.1 *Melting Process*—The steel shall be made by open-hearth or electric-furnace process, with or without separate refining such as argon-oxygen-decarburization (AOD), unless otherwise designated by the individual specification.

### 4.2 Heat Treatment:

4.2.1 Ferritic and martensitic steel shall be cooled after pouring to provide substantially complete transformation of austenite prior to heat treatment to enhance mechanical properties.

4.2.2 Castings shall be heat treated in the working zone of a furnace that has been surveyed in accordance with Test Method A 991/A 991M.

4.2.2.1 When castings are heat treated at temperatures above 2000°F [1100°C], then the working zone shall have been established by a survey performed at not more than 25°F [15°C] below nor more than 200°F [110°C] above the minimum heat treatment temperature specified for the grade. If a minimum heat treatment temperature is not specified for the grade, then the survey temperature shall be not more than 50°F [30°C] below nor more than 175°F [100°C] above the furnace set point used.

4.2.2.2 The maximum variation in measured temperature as determined by the difference between the highest temperature and the lowest temperature shall be as agreed between the purchaser and producer except that during production heat treatment no portion of the furnace shall be below the minimum specified temperature nor above the maximum specified temperature for the grade being processed.

## 5. Chemical Composition

5.1 *Chemical Analysis*—Chemical analysis of materials covered by this specification shall be in accordance with Test Methods A 751.

5.2 *Heat Analysis*—An analysis of each heat shall be made by the manufacturer to determine the percentages of the elements specified. The analysis shall be made from a test sample preferably taken during the pouring of the heat. When drillings are used, they shall be taken not less than ¼ in. [6.4 mm] beneath the surface. The chemical composition thus determined shall be reported to the purchaser, or his representative, and shall conform to the requirements in the individual specification for the grade being poured.

5.3 *Product Analysis*—A product analysis may be made by the purchaser from material representing each heat, lot, or casting. The analysis shall be made on representative material. Due to the possibility of decarburization, carbon and alloy steel samples for carbon analysis shall be taken no closer than ¼ in. [6.4 mm] to a cast surface except that castings too thin for this shall be analyzed on representative material. The chemical composition thus determined shall meet the requirements specified in the applicable specification for the grade involved, or shall be subject to rejection by the purchaser, except that the chemical composition determined for carbon and low-alloy steel castings may vary from the specified limits by the amounts shown in Table 1. The product analysis tolerances of Table 1 are not applicable as acceptance criteria for heat analysis by the casting manufacturer.

<sup>4</sup> Available from American National Standards Institute, 25 W. 43rd St., 4th Floor, New York, NY 10036.

<sup>5</sup> Available from the Manufacturers' Standardization Society of the Valve and Fittings Industry, 127 Park St., NE, Vienna, VA 22180.

**TABLE 1 Product Analysis Tolerances for Carbon and Low-Alloy Steels**

Element	Range <sup>A</sup>	Tolerances <sup>B,C</sup> over max or under min, Limit, %
Carbon (C)	up to 0.65 % above 0.65 %	$0.03 \times \% C_L + 0.02$ 0.04 %
Manganese (Mn)	up to 1 % above 1 %	$0.08 \times \% Mn_L + 0.01$ 0.09
Silicon (Si)	up to 0.60 % above 0.60 %	$0.22 \times \% Si_L - 0.01$ 0.15 %
Phosphorus (P)	all	$0.13 \times \% P_L + 0.005$
Sulfur (S)	all	$0.36 \times \% S_L + 0.001$
Nickel (Ni)	up to 2 % above 2 %	$0.10 \times \% Ni_L + 0.03$ 0.25 %
Chromium (Cr)	up to 2 % above 2 %	$0.07 \times \% Cr_L + 0.04$ 0.18 %
Molybdenum (Mo)	up to 0.6 % above 0.6 %	$0.04 \times \% Mo_L + 0.03$ 0.06 %
Vanadium (V)	up to 0.25 % above 0.25 %	$0.23 \times \% V_L + 0.004$ 0.06 %
Tungsten (W)	up to 0.10 % above 0.10 %	$0.08 \times \% W_L + 0.02$ 0.02 %
Copper (Cu)	up to 0.15 % above 0.15 %	$0.18 \times \% Cu_L + 0.02$ 0.05 %
Aluminum (Al)	up to 0.03 % 0.03 to 0.10 %, incl. above 0.10 %	0.01 % $0.08 \times \% Al + 0.02$ 0.03 %

<sup>A</sup> The range denotes the composition limits up to which the tolerances are computed by the equation, and above which the tolerances are given by a constant.

<sup>B</sup> The subscript  $L$  for the elements in each equation indicates that the limits of the element specified by the applicable specification are to be inserted into the equation to calculate the tolerance for the upper limit and the lower limit, if applicable, respectively. Examples of computing tolerances are presented in the footnote C.

<sup>C</sup> To compute the tolerances, consider the manganese limits 0.50 – 80 % of Grade WC4 of Specification A 217/A 217M. According to Table 1, the maximum permissible deviation of a product analysis below the lower limit 0.50 is  $0.05 \% = (0.08 \times 0.50 + 0.01)$ . The lowest acceptable product analysis of Grade WC4, therefore, is 0.45 %. Similarly, the maximum permissible deviation above the upper limit of 0.80 % is  $0.074 \% = (0.08 \times 0.80 + 0.01)$ . The highest acceptable product analysis of Grade WC4, therefore, is 0.874. For Grade WCC of Specification A 216/A 216M, the maximum manganese content is 1.20 % if the carbon content is 0.20 %. In this case, the highest acceptable product analysis is  $1.29 = (1.20 + 0.09)$ .

5.4 *Unspecified Elements*—When chemical analysis for elements not specified for the grade ordered is desired, Supplementary Requirement S1 may be specified.

5.4.1 Grade substitution for stainless and nickel base alloy castings is not permitted. Grade substitution occurs when the material supplied: (1) contains an element, other the nitrogen, that is not specified in the ordered grade, and (2) the amount of that element equals or exceeds the minimum requirement for the element in another grade for which it is specified. For this requirement, a grade is defined as an alloy described individually in a table of chemical requirements within any specification listed within the scope of this section.

5.5 The substitution of a grade or composition different from that specified by the purchaser is prohibited.

5.6 Where more than one ladle is poured into a single casting, the molten metal in each ladle must conform to the specified chemical requirements.

## 6. Mechanical Test Methods

6.1 All mechanical tests shall be conducted in accordance with Test Methods and Definitions A 370.

## 7. Tensile Requirements

7.1 One tension test shall be made from each heat, and shall conform to the tensile requirements specified. Test bars shall be poured in special blocks from the same heat as the castings represented, except that for investment castings the test specimens shall be cast in the same type of mold as the castings.<sup>6</sup>

7.2 The bar from which the test specimen is taken shall be heat treated in production furnaces to the same procedure as the castings it represents.

7.3 Test specimens may be cut from heat treated castings, at the producer's option, instead of from test bars.

7.4 *Investment Castings*—For investment castings, the specimens may be cast to shape or machined from blocks to dimensions in accordance with Test Methods and Definitions 370 or the ICI bar shown in Fig. 1.

7.5 *Other Castings*—Unless otherwise specified by the purchaser, test coupons may be cast integrally with the castings or as separate blocks in accordance with Fig. 2 and Table 2, with Fig. 3, or with Fig. 4, except when Supplementary Requirement S26 is specified. The test coupon in Fig. 4 shall be employed only for austenitic alloy castings with cross sections less than  $2\frac{1}{2}$  in. [63.5 mm]. Tension test coupons shall be machined or ground to the form and dimension shown in Fig. 6 of Test Methods and Definitions A 370.

7.6 If any specimen shows defective machining or develops flaws, it may be discarded and another substituted from the same heat.

7.7 To determine conformance with the tension test requirements, an observed value or calculated value shall be rounded off in accordance with Practice E 29 to the nearest 500 psi [5 MPa] for yield and tensile strength and to the nearest 1 % for elongation and reduction of area.

## 8. Repair by Welding

8.1 Repair by welding shall be in accordance with the requirements of individual specification using procedures and welders qualified in accordance with Practice A 488/A 488M.

## 9. Flanges

9.1 When a flange from a flanged casting is removed to make a weld end casting, discontinuities may be observed that would not have been detrimental in a flanged casting. The disposition of the casting shall be subject to agreement between the purchaser and manufacturer.

## 10. Quality

10.1 The surface of the casting shall be free of adhering sand, scale, cracks, and hot tears as determined by visual examination. Other surface discontinuities shall meet the visual acceptance standards specified in the order. Practice A 802/A 802M or other visual standards may be used to define acceptable surface discontinuities and finish. Unacceptable

<sup>6</sup> Information on the relationship of mechanical properties determined on test coupons obtained as specified in 7.1 and 7.4 with those obtained from the casting may be found in "The Steel Castings Handbook," Fifth Edition, Steel Founders' Society of America, 1980, pp. 15–35 through 15–43.

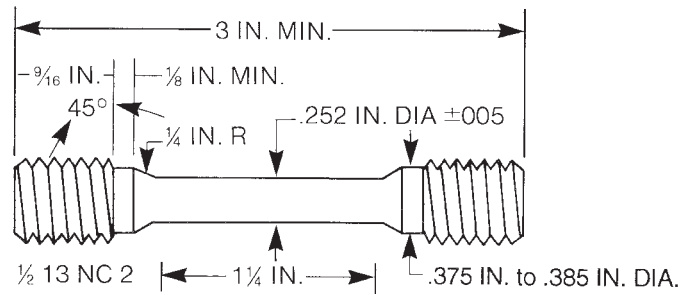

Metric Equivalents

in.	0.005	1/8	0.252	0.375	0.385	1/16	1 1/4	3
[mm]	[0.15]	[3]	[6.40]	[9.50]	[9.75]	[15]	[30]	[75]

FIG. 1 Design and Dimensions of the ICI Test Bar

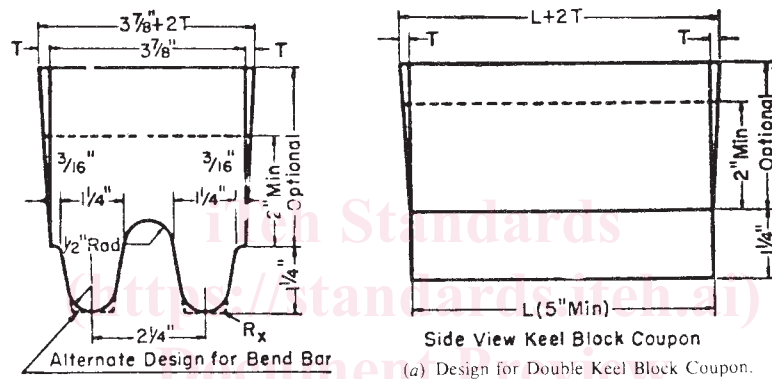

(a) Design for Double Keel Block Coupon.

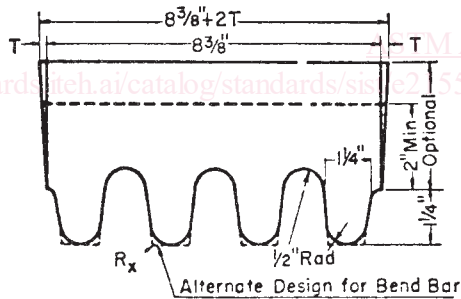

(b) Design for Multiple Keel Block Coupon (4 Legs).

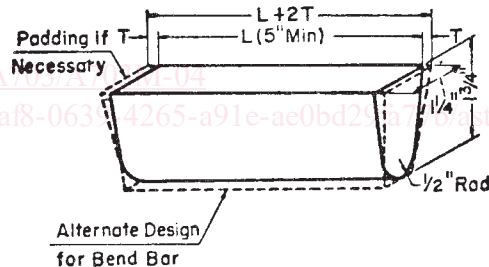

(c) Design for "Attached" Coupon.

Metric Equivalents

in.	3/16	1/2	1 1/4	1 3/4	2	2 1/4	3 7/8	5	8 1/8
mm	4.8	13	32	45	51	57	98	127	213

FIG. 2 Test Coupons for Castings (see Table 2 for Details of Design)

visual surface discontinuities shall be removed and their removal verified by visual examination of the resultant cavities.

10.2 The castings shall not be peened, plugged, or impregnated to stop leaks.

10.3 Internal chills and chaplets may be used in the manufacture of castings. However, the chills, chaplets, and affected cast material must be completely removed.

11. Hydrostatic Tests

11.1 Each casting shall be tested after machining to the hydrostatic shell test pressures prescribed in ANSI B16.5 for the applicable steel rating for which the casting is designed. Casting shall show no leaks. Castings ordered for working pressures other than those in the standard ANSI ratings, or those listed for which test pressures are not specified by ANSI

**TABLE 2 Details of Test Coupon Design for Casting (See Fig. 2)**

NOTE 1—*Test Coupons for Large and Heavy Steel Castings:* The test coupons in Fig. 2 are to be used for large and heavy steel castings. However, at the option of the foundry the cross-sectional area and length of the standard coupon may be increased as desired.

NOTE 2—*Bend Bar:* If a bend bar is required, an alternate design (as shown by dotted lines in Fig. 2) is indicated.

	Leg Design [125 mm]		Riser Design
1. <i>L</i> (length)	A 5 in. [125 mm] minimum length will be used. This length may be increased at the option of the foundry to accommodate additional test bars (see Note 1).	1. <i>L</i> (length)	The length of the riser at the base will be the same as the top length of the leg. The length of the riser at the top therefore depends on the amount of taper added to the riser.
2. End taper	Use of and size of end taper is at the option of the foundry.	2. Width	The width of the riser at the base of a multiple-leg coupon shall be $n, 2\frac{1}{4}$ [57 mm] – $\frac{5}{8}$ [16 mm] where <i>n</i> equals the number of legs attached to the coupon. The width of the riser at the top is therefore dependent on the amount of taper added to the riser.
3. Height	$1\frac{1}{4}$ in. [32 mm]	3. <i>T</i> (riser taper)	Use of and size is at the option of the foundry.
4. Width (at top)	$1\frac{1}{4}$ in. [32 mm] (see Note 1).	Height	The minimum height of the riser shall be 2 in. [51 mm]. The maximum height is at the option of the foundry for the following reasons: (a) Many risers are cast open, (b) different compositions may require variation in risering for soundness, (c) different pouring temperatures may require variation in risering for soundness.
5. Radius (at bottom)	$\frac{1}{2}$ in. [13 mm], max		
6. Spacing between legs	A $\frac{1}{2}$ -in. [13-mm] radius will be used between the legs.		
7. Location of test bars	The tensile, bend, and impact bars will be taken from the lower portion of the leg (see Note 2).		
8. Number of legs	The number of legs attached to the coupon is at the option of the foundry providing they are equispaced according to Item 6.		
9. <i>R<sub>s</sub></i>	Radius from 0 to approximately $\frac{1}{16}$ in. [2 mm].		

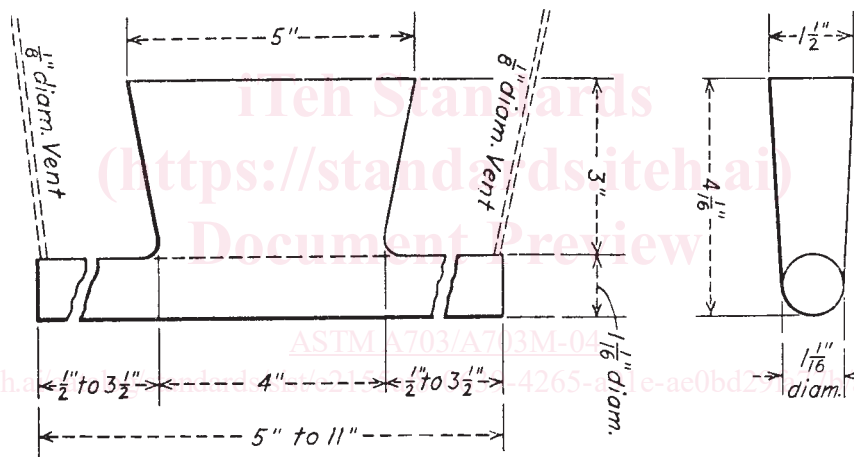

**Metric Equivalents**

in.	mm	in.	mm
1/8	3.2	3/2	88.9
1/2	12.7	4	101.6
1 1/16	27.0	4 1/16	103.2
1 1/2	38.1	5	127.0
3	76.2	11	279.4

NOTE—Pour through head; cover molten head with powdered charcoal, coke dust, etc., immediately after pouring, in order to keep head fluid as long as possible.

**FIG. 3 Test Block for Tension Test Specimen**

B16.5, shall be tested at a pressure agreed upon between manufacturer and the purchaser.

11.2 It is realized that the foundry may be unable to perform the hydrostatic test prior to shipment, or that the purchaser may wish to defer testing until additional work or machining has been performed on the casting. Castings ordered in the rough state for final machining by the purchaser may be tested hydrostatically prior to shipment by the manufacturer at

pressures to be agreed upon with the purchaser. However, the foundry is responsible for the satisfactory performance of the castings under the final test required in 10.1.

## 12. Workmanship, Finish, and Appearance

12.1 All castings shall be made in a workmanlike manner and shall conform to the dimensions on drawings furnished by the purchaser. When the pattern is supplied by the purchaser,

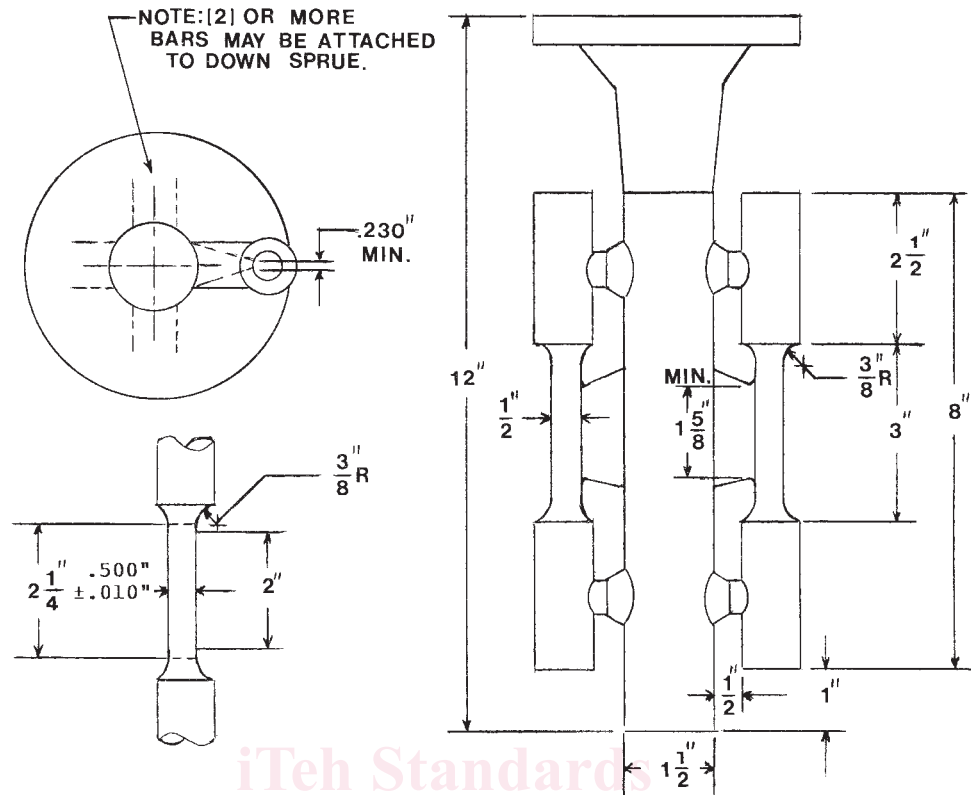

**Metric Equivalents**

in.	mm	in.	mm
0.010	0.254	1/8	41.275
0.230	5.842	2 1/4	57.15
3/8	9.525	2 1/2	63.5
1/2	12.7	3	76.2
1	25.4	8	203.2
1 1/2	38.1	12	304.8

NOTE—Coupons produced in this manner are suitable for austenitic alloys only. The mold may be preheated for pouring to produce a sound coupon.

**FIG. 4 Cast-To-Shape Test Coupon for Tension Test Specimen**

the dimensions of the casting shall be as predicated by the pattern unless otherwise agreed upon.

12.2 Machined welding ends shall be suitably protected against damage during shipping.

**13. Retests**

13.1 If the results of the mechanical tests for any heat, lot, or casting do not conform to the requirements specified, retests are permitted as outlined in Test Methods and Definitions A 370. At the manufacturer's option, castings may be reheat-treated and retested. When castings are reheat-treated, they may not be reaustenitized more than three times without the approval of the purchaser. Testing after reheat treatment shall consist of the full number of specimens taken from locations complying with the specification or order.

**14. Inspection**

14.1 The manufacturer shall afford the purchaser's inspector all reasonable facilities necessary to satisfy that the material is

being produced and furnished in accordance with the applicable specification. Foundry inspection by the purchaser shall not interfere unnecessarily with the manufacturer's operations. All tests and inspections, with the exception of product analysis (5.2), shall be made at the place of manufacture unless otherwise agreed.

**15. Rejection and Rehearing**

15.1 Any rejection based on test reports shall be reported to the manufacturer within 30 days from the receipt of the test reports by the purchaser.

15.2 Material that shows unacceptable discontinuities as determined by the acceptance standards specified in the order subsequent to its acceptance at the manufacturer's works will be rejected, and the manufacturer shall be notified within 30 days after discovery of the rejectable condition.