



# SLOVENSKI STANDARD

## SIST EN 861:2008+A1:2009

01-oktober-2009

---

### Varnost lesnoobdelovalnih strojev - Kombinirani in debelinski skobeljniki

Safety of woodworking machines - Surface planing and thicknessing machines

Sicherheit von Holzbearbeitungsmaschinen - Kombinierte Abricht- und Dickenhobelmaschinen

Sécurité des machines pour le travail du bois - Machines combinées à raboter et à dégauchir

**iTeh STANDARD PREVIEW**  
**(standards.iteh.ai)**

Ta slovenski standard je istoveten z: **EN 861:2007+A1:2009**

SIST EN 861:2008+A1:2009  
<https://standards.iteh.ai/catalog/standards/sist/c2b458af-5b15-4402-8cc3-08913b6e39ba/sist-en-861-2008a1-2009>

---

#### **ICS:**

25.080.25      Stroji za ploščinsko obdelavo      Planing machines

79.120.10      Lesnoobdelovalni stroji      Woodworking machines

**SIST EN 861:2008+A1:2009**

**en**

**iTeh STANDARD PREVIEW**  
**(standards.iteh.ai)**

SIST EN 861:2008+A1:2009

<https://standards.iteh.ai/catalog/standards/sist/c2b438af-3bf3-4402-8cc3-08913b6e39ba/sist-en-861-2008a1-2009>

EUROPEAN STANDARD  
NORME EUROPÉENNE  
EUROPÄISCHE NORM

**EN 861:2007+A1**

August 2009

ICS 79.120.10

Supersedes EN 861:2007

English Version

## Safety of woodworking machines - Surface planing and thicknessing machines

Sécurité des machines pour le travail du bois - Machines  
combinées à raboter et à dégauchir

Sicherheit von Holzbearbeitungsmaschinen - Kombinierte  
Abricht- und Dickenhobelmaschinen

This European Standard was approved by CEN on 10 May 2007 and includes Corrigendum 1 issued by CEN on 29 October 2008 and Amendment 1 approved by CEN on 16 July 2009.

CEN members are bound to comply with the CEN/CENELEC Internal Regulations which stipulate the conditions for giving this European Standard the status of a national standard without any alteration. Up-to-date lists and bibliographical references concerning such national standards may be obtained on application to the CEN Management Centre or to any CEN member.

This European Standard exists in three official versions (English, French, German). A version in any other language made by translation under the responsibility of a CEN member into its own language and notified to the CEN Management Centre has the same status as the official versions.

CEN members are the national standards bodies of Austria, Belgium, Bulgaria, Cyprus, Czech Republic, Denmark, Estonia, Finland, France, Germany, Greece, Hungary, Iceland, Ireland, Italy, Latvia, Lithuania, Luxembourg, Malta, Netherlands, Norway, Poland, Portugal, Romania, Slovakia, Slovenia, Spain, Sweden, Switzerland and United Kingdom.

[SIST EN 861:2008+A1:2009](https://standards.iteh.ai/catalog/standards/sist/c2b438af-3bf3-4402-8cc3-08913b6e39ba/sist-en-861-2008a1-2009)

<https://standards.iteh.ai/catalog/standards/sist/c2b438af-3bf3-4402-8cc3-08913b6e39ba/sist-en-861-2008a1-2009>



EUROPEAN COMMITTEE FOR STANDARDIZATION  
COMITÉ EUROPÉEN DE NORMALISATION  
EUROPÄISCHES KOMITEE FÜR NORMUNG

Management Centre: Avenue Marnix 17, B-1000 Brussels

## Contents

Page

Foreword.....	4
Introduction .....	5
1 Scope .....	6
2 Normative references .....	6
3 Terms and definitions .....	8
3.1 General.....	8
3.2 Definitions .....	8
3.3 Terms .....	10
4 List of significant hazards .....	12
5 Safety requirements and/or measures .....	16
5.1 General.....	16
5.2 Controls .....	16
5.2.1 Safety and reliability of control systems.....	16
5.2.2 Position of controls .....	17
5.2.3 Starting .....	17
5.2.4 Normal stopping .....	18
5.2.5 Emergency stop .....	19
5.2.6 Failure of the power supply .....	20
5.2.7 Failure of the control circuit .....	20
5.3 Protection against mechanical hazards .....	20
5.3.1 Stability .....	20
5.3.2 Hazard of break up during operation.....	21
5.3.3 Tool holder and tool design.....	21
5.3.4 Braking.....	21
5.3.5 Devices to minimise the possibility or the effect of ejection .....	22
5.3.6 Work-piece supports and guides .....	23
5.3.7 Prevention of access to moving parts.....	27
5.3.8 Guarding of drives .....	31
5.3.9 Characteristics of tool guards.....	32
5.3.10 Safety appliances.....	32
5.3.11 Demountable power feed .....	33
5.4 Protection against non-mechanical hazards .....	33
5.4.1 Fire .....	33
5.4.2 Noise .....	33
5.4.3 Emission of chips and dust.....	34
5.4.4 Electricity.....	35
5.4.5 Ergonomics and handling.....	35
5.4.6 Pneumatics.....	36
5.4.7 Hydraulics.....	36
5.4.8 Electromagnetic compatibility.....	36
5.4.9 Supply disconnection (isolation) .....	37
5.4.10 Static electricity .....	37
5.4.11 Maintenance .....	37
6 Information for use .....	38
6.1 General.....	38
6.2 Marking .....	38
6.3 Instruction handbook .....	39
Annex A (normative) Tests for bridge type guards for planing machines.....	42

A.1	Compression test .....	42
A.2	Shock test.....	42
A.3	Strength test for bridge type guard .....	42
<b>Annex B</b>	<b>(normative) Table lip resistance test.....</b>	<b>44</b>
B.1	General .....	44
B.2	Work-piece .....	44
B.3	Measurements .....	46
B.4	Test .....	47
B.5	Result.....	47
<b>Annex C</b>	<b>(normative) Kickback test .....</b>	<b>49</b>
<b>Annex D</b>	<b>(normative) Stability test for displaceable machines .....</b>	<b>50</b>
D.1	Stability test in the surfacing mode.....	50
D.2	Stability test in the thickening mode.....	50
<b>Annex E</b>	<b>(normative) Impact test method for guards .....</b>	<b>52</b>
E.1	General .....	52
E.2	Test method .....	52
E.2.1	Preliminary remarks .....	52
E.2.2	Testing equipment.....	52
E.2.3	Projectile for guards.....	52
E.2.4	Sampling.....	52
E.2.5	Test procedure.....	52
E.3	Results.....	53
E.4	Assessment .....	53
E.5	Test report.....	53
E.6	Test equipment for impact test.....	53
<b>Annex F</b>	<b>(informative) Use of well- tried components .....</b>	<b>55</b>
<b>Annex G</b>	<b>(normative) Use of electronic components .....</b>	<b>56</b>
G.1	General .....	56
G.2	SRECS design.....	56
G.2.1	Components, hardware.....	56
G.2.2	Safety related software .....	57
<b>Annex H</b>	<b>(normative) Braking tests .....</b>	<b>59</b>
H.1	Conditions for all tests.....	59
H.2	Unbraked run-down time .....	59
H.3	Braked run-down time.....	59
<b>Annex ZA</b>	<b>(informative) Relationship between this European Standard and the Essential Requirements of EU Directive 98/37/EC.....</b>	<b>60</b>
<b>Annex ZB</b>	<b>(informative) <math>\overline{A_1}</math> Relationship between this European Standard and the Essential Requirements of EU Directive 2006/42/EC <math>\overline{A_1}</math> .....</b>	<b>63</b>
<b>Bibliography</b>	<b>.....</b>	<b>67</b>

**EN 861:2007+A1:2009 (E)****Foreword**

This document (EN 861:2007+A1:2009) has been prepared by Technical Committee CEN/TC 142 "Woodworking machines - Safety", the secretariat of which is held by UNI.

This European Standard shall be given the status of a national standard, either by publication of an identical text or by endorsement, at the latest by February 2010, and conflicting national standards shall be withdrawn at the latest by February 2010.

Attention is drawn to the possibility that some of the elements of this document may be the subject of patent rights. CEN [and/or CENELEC] shall not be held responsible for identifying any or all such patent rights.

This document includes Amendment 1, approved by CEN on 2009-07-16 and Corrigendum 1, issued by CEN on 2008-10-29.

This document supersedes A1 EN 861:2007 A1.

The start and finish of text introduced or altered by amendment is indicated in the text by tags A1 A1.

The modifications of the related CEN Corrigendum have been implemented at the appropriate places in the text and are indicated by the tags AC AC.

This document has been prepared under a mandate given to CEN by the European Commission and the European Free Trade Association, and supports essential requirements of the Machinery Directive.

A1 For relationship with EU Directive(s), see informative Annexes ZA and ZB, which are integral parts of this document. A1

Organisation contributing to the preparation of the European Standard include the European Association of Manufacturer of Woodworking Machines "EUMABOIS".

The European Standards produced by CEN/TC 142 are particular to woodworking machines and complement the relevant A and B standards on the subject of general safety (see introduction of EN ISO 12100-1:2003 for a description of A, B and C standards).

According to the CEN/CENELEC Internal Regulations, the national standards organizations of the following countries are bound to implement this European Standard: Austria, Belgium, Bulgaria, Cyprus, Czech Republic, Denmark, Estonia, Finland, France, Germany, Greece, Hungary, Iceland, Ireland, Italy, Latvia, Lithuania, Luxembourg, Malta, Netherlands, Norway, Poland, Portugal, Romania, Slovakia, Slovenia, Spain, Sweden, Switzerland and United Kingdom.

## Introduction

This document has been prepared to be a harmonised standard to provide one means of conforming to the essential safety requirements of the Machinery Directive, and associated EFTA regulations.

This document is a type “C” standard as stated in EN ISO 12100-1:2003.

The machinery concerned and the extent to which hazards, hazardous situations and events are covered are indicated in the scope of this document.

When provisions of this type C standard are different from those which are stated in type A or B standards, the provisions of this type C standard take precedence over the provisions of other standards, for machines that have been designed and built according to the provisions of this type C standard.

The requirements of this document are directed to manufacturers and their authorised representatives of surface planing and thicknessing machines. They are also useful for designers and importers.

This document also includes provision and examples of information to be provided by the manufacturer to the user.

Common requirements for tooling are given in EN 847-1:2005.

**ITIH STANDARD PREVIEW**  
**(standards.iteh.ai)**

SIST EN 861:2008+A1:2009

<https://standards.iteh.ai/catalog/standards/sist/c2b438af-3bf3-4402-8cc3-08913b6e39ba/sist-en-861-2008a1-2009>

**EN 861:2007+A1:2009 (E)****1 Scope**

This document <sup>[A1]</sup> specifies all significant <sup>[A1]</sup> hazards, hazardous situation and events as listed in Clause 4 relevant to stationary and displaceable surface planing and thicknessing machines with an integrated feed in thicknessing mode, (with or without demountable power feed unit in planing mode) and with manual loading and unloading of the work-piece, hereinafter referred to as "machines". The cutterblock is fixed in position and for thicknessing an integrated feed is provided. The machines are designed to cut solid wood, chipboard, fibreboard and plywood when they are used as intended and under the conditions foreseen by the manufacturer.

This document does not deal with any hazards which result from the attachment of an optional mortising unit. These hazards are covered by prEN 940:2007.

This document does not apply to:

- a) machines set up on a bench or a table similar to a bench, which are intended to carry out work in a stationary position, capable of being lifted by one person by hand;

NOTE 1 Transportable motor-operated electric tools are covered by the requirements of EN 61029-1:2000 together with prEN 61029-2-3:2004.

- b) surface planing and thicknessing machines where the cutterblock is adjustable for depth of cut setting in thicknessing mode;

- c) machines where the conversion from planing to thicknessing mode or vice versa is achieved by mounting or demounting parts/units;

- d) machines where surfacing and thicknessing can be performed at the same time.

This document is not applicable to surface planing and thicknessing machines which are manufactured before the date of its publication as EN.

NOTE 2 Machines covered by this document are listed under A.5 of Annex IV of the Machinery Directive.

**2 Normative references**

The following referenced documents are indispensable for the application of this document. For dated references, only the edition cited applies. For undated references, the latest edition of the referenced document (including any amendments) applies.

<sup>[A1]</sup> *deleted text* <sup>[A1]</sup>

EN 847-1:2005, *Tools for woodworking — Safety requirements — Part 1: Milling tools, circular saw blades*

EN 982:1996, *Safety of machinery — Safety requirements for fluid power systems and their components — Hydraulics*

EN 983:1996, *Safety of machinery — Safety requirements for fluid power systems and their components — Pneumatics*

EN 1005-2:2003, *Safety of machinery — Human physical performance — Part 2: Manual handling of machinery and component parts of machinery*

EN 1005-4:2005, *Safety of machinery — Human physical performance — Part 4: Evaluation of working postures and movements in relation to machinery*



- EN 1037:1995, *Safety of machinery — Prevention of unexpected start-up*
- EN 1088:1995, *Safety of machinery — Interlocking devices associated with guards — Principles for design and selection*
- EN 50178:1997, *Electronic equipment for use in power installations*
- EN 50370-1:2005, *Electromagnetic compatibility (EMC) — Product family standard for machine tools — Part 1: Emission*
- EN 50370-2:2003, *Electromagnetic compatibility (EMC) — Product family standard for machine tools — Part 2: Immunity*
- EN 60204-1:2006, *Safety of machinery — Electrical equipment of machines — Part 1: General requirements (IEC 60204-1:2005, modified)*
- EN 60439-1:1999, *Low-voltage switchgear and controlgear assemblies — Part 1: Type-tested and partially type-tested assemblies (IEC 60439-1:1999)*
- EN 60529:1991, *Degree of protection provided by enclosures (IP code) (IEC 60529:1989)*
- EN 61496-1:2004, *Safety of machinery — Electro-sensitive protective equipment — Part 1: General requirements and tests (IEC 61496-1:2004, modified)*
- EN 61508-3:2001, *Functional safety of electrical/electronic/programmable electronic safety-related systems — Part 3: Software requirements (IEC 61508-3:1998 + Corrigendum 1999)*
- EN 62061:2005, *Safety of machinery — Functional safety of safety-related electrical, electronic and programmable electronic control systems (IEC 62061:2005)*
- EN ISO 3743-1:1995, *Acoustics — Determination of sound power levels of noise sources — Engineering methods for small, movable sources in reverberant fields — Part 1: Comparison method for hard-walled test rooms (ISO 3743-1:1994)*
- EN ISO 3743-2:1996, *Acoustics — Determination of sound power levels of noise sources using sound pressure — Engineering methods for small, movable sources in reverberant fields — Part 2: Methods for special reverberant test rooms (ISO 3743-2:1994)*
- EN ISO 3744:1995, *Acoustics — Determination of sound power levels of noise sources using sound pressure — Engineering method in an essentially free field over a reflecting plane (ISO 3744:1994)*
- EN ISO 3745:2003, *Acoustics — Determination of sound power levels of noise sources using sound pressure — Precision methods for anechoic and semi-anechoic rooms (ISO 3745:2003)*
- EN ISO 3746:1995, *Acoustics — Determination of sound power levels of noise sources using sound pressure — Survey method using an enveloping measurement surface over a reflecting plane (ISO 3746:1995)*
- EN ISO 4871:1996, *Acoustics — Declaration and verification of noise emission values of machinery and equipment (ISO 4871:1996)*
- EN ISO 9614-1:1995, *Acoustics — Determination of sound power levels of noise sources using sound intensity — Part 1: Measurement at discrete points (ISO 9614-1:1993)*
- EN ISO 11202:1995, *Acoustics — Noise emitted by machinery and equipment — Measurement of emission sound pressure levels at a work station and at other specified positions — Survey method in situ (ISO 11202:1995)*

**EN 861:2007+A1:2009 (E)**

EN ISO 11204:1995, *Acoustics — Noise emitted by machinery and equipment — Measurement of emission sound pressure levels at a work station and at other specified positions — Method requiring environmental corrections (ISO 11204:1995)*

EN ISO 11688-1:1998, *Acoustics — Recommended practice for the design of low-noise machinery and equipment — Part 1: Planning (ISO/TR 11688-1:1995)*

EN ISO 12100-1:2003, *Safety of machinery — Basic concepts, general principles for design — Part 1: Basic terminology, methodology (ISO 12100-1:2003)*

EN ISO 12100-2:2003, *Safety of machinery — Basic concepts, general principles for design — Part 2: Technical principles (ISO 12100-2:2003)*

☐<sub>A1</sub> EN ISO 13849-1:2008 ☐<sub>A1</sub><sup>1)</sup>, *Safety of machinery — Safety-related parts of control systems — Part 1: General principles for design (ISO 13849-1:2006)*

☐<sub>A1</sub> EN ISO 13849-2:2008 ☐<sub>A1</sub>, *Safety of machinery — Safety-related parts of control systems — Part 2: Validation (ISO 13849-2:2003)*

☐<sub>A1</sub> EN ISO 13857:2008, *Safety of machinery — Safety distances to prevent hazard zones being reached by upper and lower limbs (ISO 13857:2008) ☐<sub>A1</sub>*

ISO 7568:1986, *Woodworking machines — Thickness planing machines with rotary cutterblock for one-side dressing — Nomenclature and acceptance conditions*

ISO 7960:1995, *Airborne noise emitted by machine tools — Operating conditions for woodworking machines*

HD 22.4 S4:2004; *Cables of rated voltages up to and including 450/750 V and having crosslinked insulation — Part 4: Cords and flexible cables*

SIST EN 861:2008+A1:2009

<https://standards.iteh.ai/catalog/standards/sist/c2b438af-3bf3-4402-8cc3-08913b6e39ba/sist-en-861-2008a1-2009>

**3 Terms and definitions****3.1 General**

For the purposes of this document, the terms and definitions given in EN ISO 12100-1:2003 and the following apply:

**3.2 Definitions****3.2.1****surface planing and thicknessing machine**

combined machine designed to plane a surface of a work-piece and to give it in a following operation a set thickness by means of a horizontally rotating cutterblock, a cylindrical shaped complex tool equipped with blades with horizontal straight cutting line that cuts while rotating (see for a description of the complex tool also EN 847-1:2005)

NOTE The work-piece is fed into the machine against the direction of the cut.

When surfacing, the work-piece is passed over the cutterblock located between two tables which are used to position and support the work-piece and the lower surface is planed. The infeed table of the surface planing unit is adjustable in height.

When thicknessing, both of the surfacing tables are raised. The work-piece rests on the thicknessing table the distance between it and the cutting circle diameter is adjustable. The upper surface of the work-piece is planed

<sup>1)</sup> ☐<sub>A1</sub> EN ISO 13849-1:2006 superseded EN 954-1:1996. ☐<sub>A1</sub>

**3.2.2****thicknessing table**

table used to support the work-piece during thicknessing at the machine which may comprise an assembly of rollers, belts or other fixed or moving mechanical elements

**3.2.3****surface planing tables**

tables in front and behind the cutterblock used to support the work-piece at the machine during planing the lower surface

**3.2.4****integrated feed**

feed mechanism for the work-piece which is integrated with the machine and where the work-piece is held and controlled mechanically during the machining operation

**3.2.5****loading of a surface planing and thicknessing machine in the thicknessing mode**

manual placing of the work-piece on the thicknessing table at the infeed side with the following presentation to the integrated feed device

**3.2.6****stationery machine**

machine designed to be located on or fixed to the floor or other parts of the structure of the premises and to be stationary during use

**3.2.7****displaceable machine**

machine which is located on the floor, stationary during use and equipped with a device, normally wheels, which allows it to be moved between locations

**3.2.8****safety appliance**

additional device which is not an integral part of the machine but which assists the operator in the safe feeding of the work-piece e.g. push block or push stick

**3.2.9****demountable power feed unit**

feed mechanism which is mounted on the machine so that it can be moved from its working position to a rest position and vice versa without the use of a spanner or similar additional device

**3.2.10****kickback**

particular form of ejection describing the uncontrolled movement of the work-piece or parts of it or parts of the machine opposite to the direction of feed during processing

**3.2.11****anti-kickback device**

device which either reduces the possibility of kickback or arrests the motion during kickback of the work-piece parts of it

**3.2.12****run-down time**

elapsed time from the actuation of the stop control device to spindle stand still

**3.2.13****run-up time**

elapsed time from the actuation of the start control device until the spindle reaches the actual speed related to the intended speed

**EN 861:2007+A1:2009 (E)****3.2.14****information from the supplier**

statement, sales literature, leaflet or other documents in which a manufacturer (or supplier) declares either the characteristics of e.g. a material or product or the conformity of the material or product to a relevant standard

**3.2.15****operator position**

position in which the operator stands to feed the work-piece to the tool

**3.2.16****machine actuator**

power mechanism used to effect motion of the machine

**3.2.17****safety related electrical control system (SRECS)**

electrical part of a control system whose failure can result in a hazard (3.2.4 of EN 62061:2005)

**3.2.18****embedded software**

software that is part of the system supplied by the manufacturer and is not accessible for modification by the end user

NOTE 1 Embedded software is also referred to as firmware or system software (3.2.47 of EN 62061:2005).

NOTE 2 Manufacturer means manufacturer of the system.

EXAMPLE The operating system of a speed monitoring device.

iTeh STANDARD PREVIEW  
(standards.iteh.ai)

**3.2.19****application software**

software specific to the application specifically implemented for the SRECS

<https://standards.iteh.ai/catalog/standards/sist/c2b438af-3bf3-4402-8cc3-0891316a291b/sist-en-861-2007+A1-2009>

NOTE In general it contains logic sequences, limits and expressions that control the appropriate outputs, decisions necessary to meet SRECS functional requirements (see 3.2.46 of EN 62061:2005).

EXAMPLE The PLC program to run a machine.

**3.2.20****safety related part of a control system (SRP(CS))**

part or subpart(s) of a control system that responds to input signals and generates safety-related output signals

NOTE The combined safety-related parts of a control system start at the point where the safety-related signals are initiated (including e.g. the actuating cam and the roller of the position switch) and end at the output of the power control elements (including e.g. the main contacts of the contactor). This also includes monitoring systems (3.1 of [EN ISO 13849-1:2008](#) <sup>(A1)</sup>).

**3.3 Terms**

The names of the main parts of the machine are shown in Figures 1 a) and 1 b).

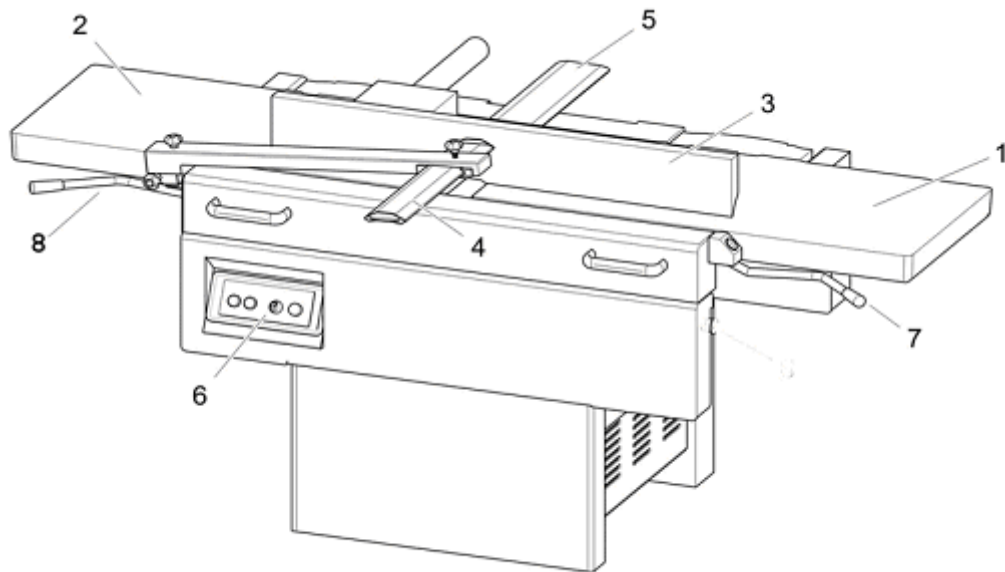

Figure 1 a) — Example of surface planing and thicknessing machine (set up for planing)

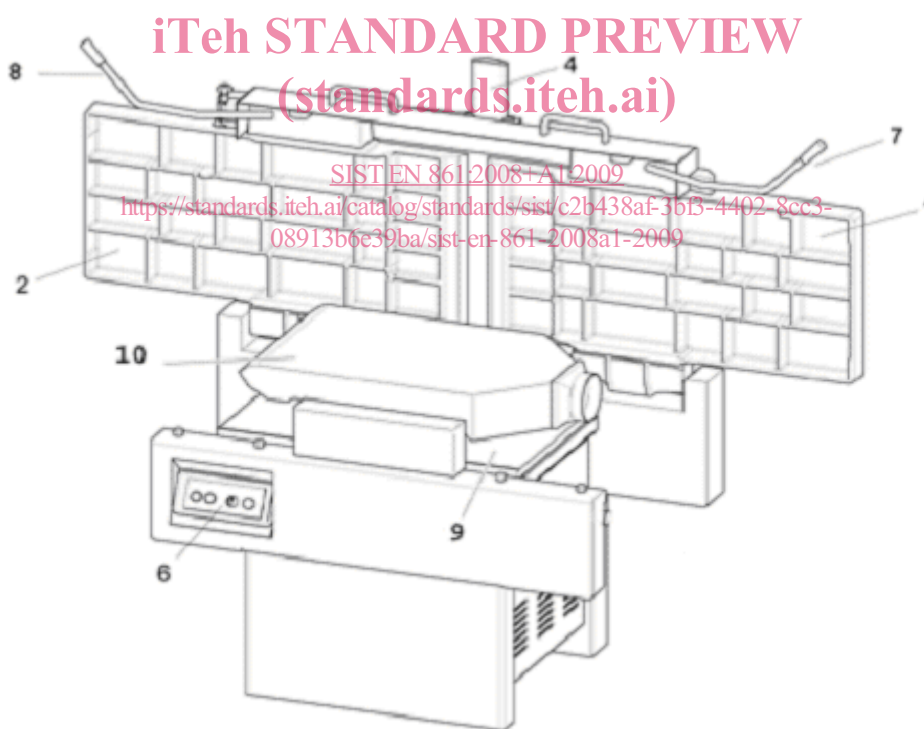

Figure 1 b) — Example of surface planing and thicknessing machine (set up for thicknessing)

**Key**

1	infeed table	6	controls
2	outfeed table	7	infeed table height adjustment
3	tiltable fence	8	bridge guard adjustment
4	bridge guard	9	thicknessing table
5	guard rear the fence	10	guard for thicknessing mode

Figure 1 — Example of surface planing and thicknessing machine

## EN 861:2007+A1:2009 (E)

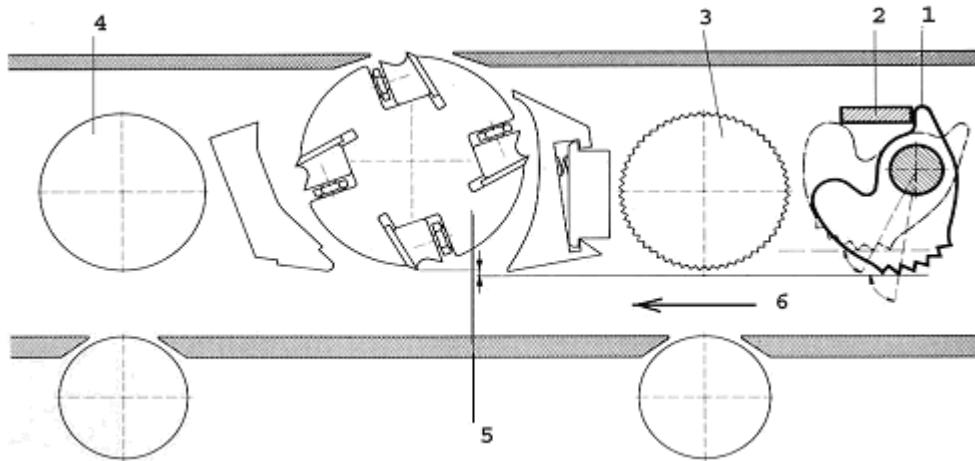
**Key**

- 1 anti kickback fingers
- 2 stop for the rotation of the finger
- 3 infeed roller
- 4 outfeed roller
- 5 cutterblock
- 6 direction of feed

**Figure 2 — Example of internal of a one side planing and thickening machine**  
 (standards.iteh.ai)

The most usual working operations when using the machine in the surface planing mode are shown in Figure 3.

<https://standards.iteh.ai/catalog/standards/sist/c2b438af-3bf3-4402-8cc3-08913b6e39ba/sist-en-861-2008a1-2009>

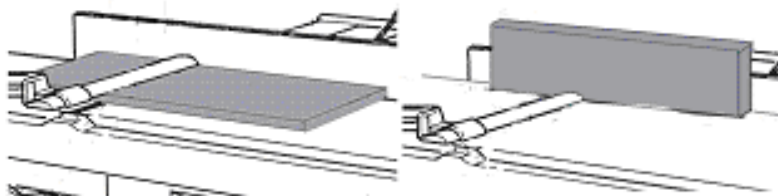

**Figure 3 — Planing (left) and edging (right)**

#### 4 List of significant hazards

This clause contains **A1** all significant **A1** hazards, hazardous situations and events (see EN 1050:1996), as far as they are dealt with in this document, identified by risk assessment as significant for the machines as defined in the scope and which require action to eliminate or reduce the risk. This document deals with these significant hazards by defining safety requirements and / or measures or by reference to relevant standards.

These hazards are listed in Table 1 in accordance with Annex A of EN 1050:1996.

Table 1 — List of significant hazards

No	Hazards, hazardous situations and hazardous events	EN ISO 12100		Relevant clause of this document
		Part 1: 2003	Part 2: 2003	
<b>1</b>	<b>Mechanical hazards</b> related to: - machine parts or work-pieces due to:			
	a) shape;	4.2	4.2.1, 4.2.2, 5	5.3.3, 5.3.5, 5.3.6, 5.3.7
	b) relative location;			5.2.2, 5.2.5, 5.3.5, 5.3.6, 5.3.7
	c) mass and stability (potential energy of elements which may move under the effect of gravity);			5.3.1, 5.3.6, 5.3.7
	d) mass and velocity (kinetic energy of elements in controlled or uncontrolled motion);			5.2.3, 5.3.7
	e) mechanical strength;			5.3.2, 5.3.3, 5.3.5, 5.3.6, 5.3.7, 5.3.8, 5.3.9, Annex A, Annex B, Annex E
	- accumulation of energy inside the machinery by:			
	f) elastic elements (springs);	4.2	4.10, 5.5.4	5.3.6, 5.3.7, 5.4.5
	g) liquids and gases under pressure;			5.4.6, 5.4.7
1.1	Crushing hazard	4.2.1		5.3.7
1.2	Shearing hazard		5.3.7	
1.3	Cutting or severing hazard		5.3.3, 5.3.7, 6.3	
1.4	Entanglement hazard		5.3.7	
1.5	Drawing-in or trapping hazard		5.3.7	
				<i>to be continued</i>