**Test conditions for manually controlled
milling machines with table of fixed
height — Testing of the accuracy —**

Part 2:

Machines with vertical spindle

iTeh STANDARD PREVIEW

*Conditions d'essai des machines à fraiser à table de hauteur fixe à
commande manuelle — Contrôle de la précision —*

Partie 2: Machines à broche verticale

ISO 1984-2:2001

<https://standards.iteh.ai/catalog/standards/sist/5b0680bc-5268-44a6-9f17-93da8636223c/iso-1984-2-2001>



PDF disclaimer

This PDF file may contain embedded typefaces. In accordance with Adobe's licensing policy, this file may be printed or viewed but shall not be edited unless the typefaces which are embedded are licensed to and installed on the computer performing the editing. In downloading this file, parties accept therein the responsibility of not infringing Adobe's licensing policy. The ISO Central Secretariat accepts no liability in this area.

Adobe is a trademark of Adobe Systems Incorporated.

Details of the software products used to create this PDF file can be found in the General Info relative to the file; the PDF-creation parameters were optimized for printing. Every care has been taken to ensure that the file is suitable for use by ISO member bodies. In the unlikely event that a problem relating to it is found, please inform the Central Secretariat at the address given below.

iTeh STANDARD PREVIEW
(standards.iteh.ai)

ISO 1984-2:2001

<https://standards.iteh.ai/catalog/standards/sist/5b0680bc-5268-44a6-9f17-93da8636223c/iso-1984-2-2001>

© ISO 2001

All rights reserved. Unless otherwise specified, no part of this publication may be reproduced or utilized in any form or by any means, electronic or mechanical, including photocopying and microfilm, without permission in writing from either ISO at the address below or ISO's member body in the country of the requester.

ISO copyright office
Case postale 56 • CH-1211 Geneva 20
Tel. + 41 22 749 01 11
Fax + 41 22 749 09 47
E-mail copyright@iso.ch
Web www.iso.ch

Printed in Switzerland

Contents

Page

Foreword.....	iv
1 Scope	1
2 Normative reference	1
3 Terminology, designation of axes and machining operations carried out.....	1
3.1 Terminology and designation of axes	1
3.2 Machining operations carried out.....	1
4 Preliminary remarks	3
4.1 Measuring units	3
4.2 References to ISO 230-1	3
4.3 Testing sequence.....	3
4.4 Tests to be performed	3
4.5 Measuring instruments	3
4.6 Machining test.....	4
4.7 Minimum tolerance	4
5 Geometric tests.....	5
5.1 Axes of motion.....	5
5.2 Table.....	8
5.3 Spindle.....	13
6 Machining test.....	16
Bibliography	17

ISO 1984-2:2001
<https://standards.iteh.ai/catalog/standards/sist/5b0680bc-5268-44a6-9f17-93da8636223c/iso-1984-2-2001>

Foreword

ISO (the International Organization for Standardization) is a worldwide federation of national standards bodies (ISO member bodies). The work of preparing International Standards is normally carried out through ISO technical committees. Each member body interested in a subject for which a technical committee has been established has the right to be represented on that committee. International organizations, governmental and non-governmental, in liaison with ISO, also take part in the work. ISO collaborates closely with the International Electrotechnical Commission (IEC) on all matters of electrotechnical standardization.

International Standards are drafted in accordance with the rules given in the ISO/IEC Directives, Part 3.

Draft International Standards adopted by the technical committees are circulated to the member bodies for voting. Publication as an International Standard requires approval by at least 75 % of the member bodies casting a vote.

Attention is drawn to the possibility that some of the elements of this part of ISO 1984 may be the subject of patent rights. ISO shall not be held responsible for identifying any or all such patent rights.

International Standard ISO 1984-2 was prepared by Technical Committee ISO/TC 39, *Machine tools*, Subcommittee SC 2, *Test conditions for metal cutting machine tools*.

This first edition of ISO 1984-2, together with ISO 1984-1, cancels and replaces ISO 1984:1982 and ISO 1984-0:1984, of which they constitute a technical revision.

ISO 1984 consists of the following parts, under the general title *Test conditions for manually controlled milling machines with table of fixed height — Testing of the accuracy*.

- *Part 1: Machines with horizontal spindle*
- *Part 2: Machines with vertical spindle*

Test conditions for manually controlled milling machines with table of fixed height — Testing of the accuracy —

Part 2: Machines with vertical spindle

1 Scope

This part of ISO 1984 specifies, with reference to ISO 230-1, both geometric and machining tests on general purpose and normal-accuracy milling machines with table of fixed height and with a vertical spindle. It also specifies the applicable tolerances corresponding to the above-mentioned tests.

This part of ISO 1984 deals only with the verification of the geometric accuracy of the machine. It does not apply to the testing of the machine operation (vibrations, abnormal noises, stick-slip motion of components, etc.), nor to checking of its characteristics (speeds, feeds, etc.), which should generally be checked before testing the accuracy.

This part of ISO 1984 defines the terminology used for the principal elements of the machine and indicates the designation of axes in accordance with ISO 84111.

NOTE Numerically controlled milling machines are covered by ISO 10791-2^[2].

<https://standards.iteh.ai/catalog/standards/sist/5b0680bc-5268-44a6-9f17-93da8636223c/iso-1984-2-2001>

2 Normative reference

The following normative document contains provisions which, through reference in this text, constitute provisions of this part of ISO 1984. For dated references, subsequent amendments to, or revisions of, any of these publications do not apply. However, parties to agreements based on this part of ISO 1984 are encouraged to investigate the possibility of applying the most recent editions of the normative documents indicated below. For undated references, the latest edition of the normative document referred to applies. Members of ISO and IEC maintain registers of currently valid International Standards.

ISO 230-1:1996, *Test code for machine tools — Part 1: Geometric accuracy of machines operating under no-load or finishing conditions*.

3 Terminology, designation of axes and machining operations carried out

3.1 Terminology and designation of axes

See Figure 1 and Table 1.

3.2 Machining operations carried out

See Figure 2.

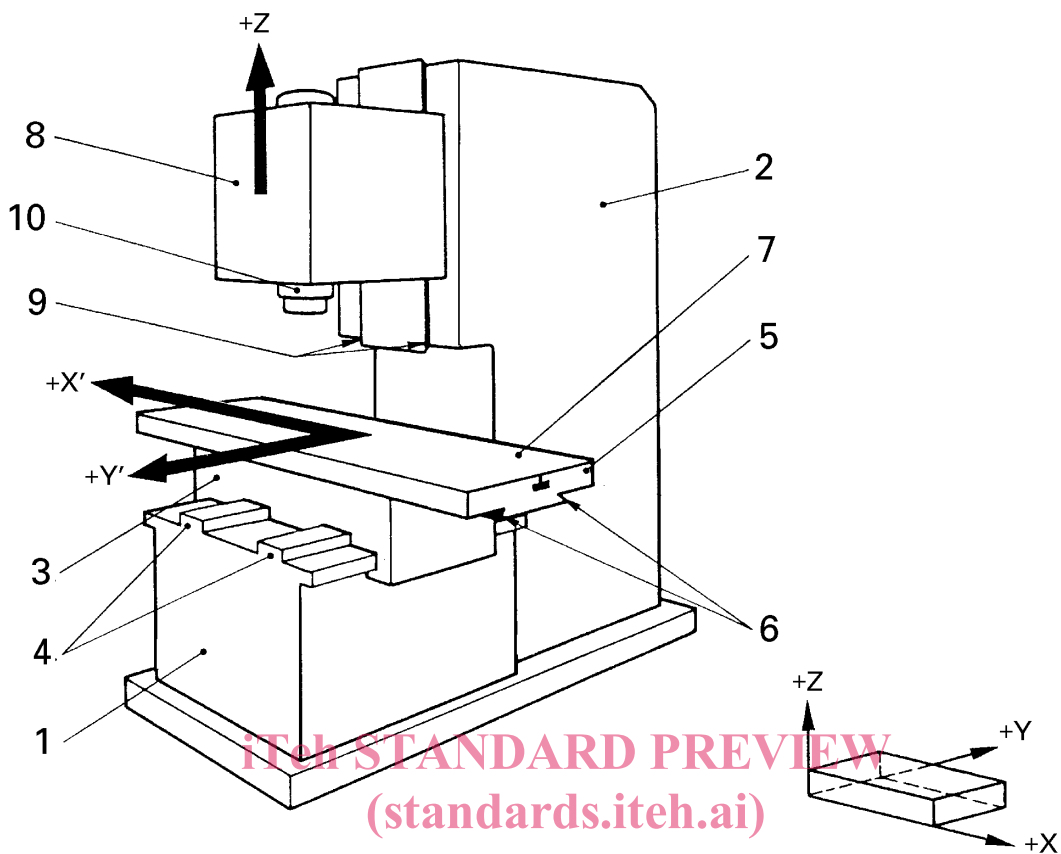

ISO 1984-2:2001
<https://standards.iteh.ai/catalog/standards/sist/5b0680bc-5268-44a6-9f17-93da8636223c/iso-1984-2-2001>
Figure 1 — Machines with vertical spindle

Table 1 — Terminology

Reference	English	French
1	Bed	Banc
2	Column	Montant
3	Saddle/cross-slide	Chariot
4	Saddle slideways	Glissières de selle
5	Table	Table
6	Table slideways	Glissières de table
7	Table surface	Surface de fixation
8	Spindle head	Poupée porte-broche
9	Spindle head slideways	Glissières de poupée porte-broche
10	Spindle nose	Nez de broche

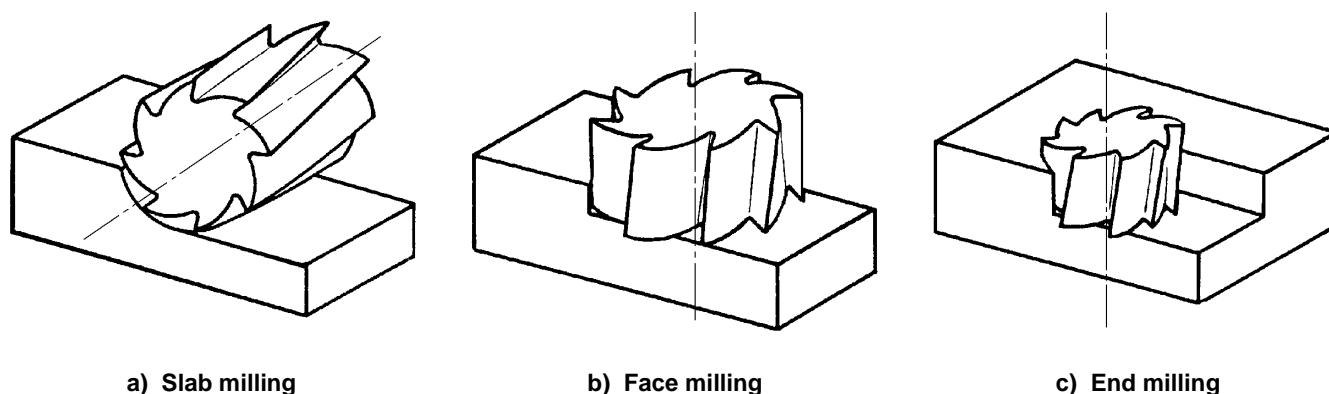

Figure 2 — Milling operations

4 Preliminary remarks

4.1 Measuring units

In this part of ISO 1984, all linear dimensions, deviations and corresponding tolerances are expressed in millimetres; angular dimensions are expressed in degrees, and angular deviations and the corresponding tolerances are expressed in ratios as the primary method, but in some cases microradians or arc seconds may be used for clarification purposes. The equivalence of the following expressions should always be kept in mind:

$$0,010/1000 = 10 \mu\text{rad} \approx 2''$$

(standards.iteh.ai)

4.2 References to ISO 230-1

ISO 1984-2:2001

<https://standards.iteh.ai/catalog/standards/sist/5b0680bc-5268-44a6-9f17->

To apply this part of ISO 1984, reference shall be made to ISO 230-1, especially for the installation of the machine before testing, warming up of the spindle and other moving components, description of measuring methods and recommended accuracy of testing equipment.

In the "Observations" block of the tests described in clauses 5 and 6, the instructions are followed by a reference to the corresponding clause in ISO 230-1 in cases where the test concerned is in compliance with the specifications of ISO 230-1.

4.3 Testing sequence

The sequence in which the tests are presented in this part of ISO 1984 in no way defines the practical order of testing. In order to make the mounting of instruments or gauging easier, tests may be performed in any order.

4.4 Tests to be performed

When testing a machine, it is not always necessary nor possible to carry out all the tests described in this part of ISO 1984. When the tests are required for acceptance purposes, it is up to the user to choose, in agreement with the supplier/manufacture, those tests relating to the components and/or the properties of the machine which are of interest. These tests are to be clearly stated when ordering a machine.

4.5 Measuring instruments

The measuring instruments indicated in the tests described in clauses 5 and 6 are examples only. Other instruments measuring the same quantities and having at least the same accuracy may be used. Dial gauges shall have a resolution of 0,001 mm.

4.6 Machining test

Machining tests shall be made with finishing cuts only, not with roughing cuts which are liable to generate appreciable cutting forces.

4.7 Minimum tolerance

When establishing the tolerance for a measuring length different from that given in this part of ISO 1984 (see 2.311 of ISO 230-1:1996), it shall be taken into consideration that the minimum value of tolerance is 0,005 mm.

iTeh STANDARD PREVIEW
(standards.iteh.ai)

ISO 1984-2:2001

<https://standards.iteh.ai/catalog/standards/sist/5b0680bc-5268-44a6-9f17-93da8636223c/iso-1984-2-2001>

5 Geometric tests

5.1 Axes of motion

<p>Object</p> <p>Checking of straightness of the vertical movement of the spindle-head slide (Z-axis):</p> <p>a) in the YZ-plane (EYZ);</p> <p>b) in the ZX-plane (EXZ).</p>	<p>G1</p>
<p>Diagram</p> <p style="text-align: center;">a) ISO 1984-2:2001 b)</p>	
<p>Tolerance</p> <p>For a) and b)</p> <p>0,025 for a measuring length of 300</p>	<p>Measured deviation</p> <p>a)</p> <p>b)</p>
<p>Measuring instruments</p> <p>Dial gauge and square</p>	
<p>Observations and references to ISO 230-1:1996 5.232.11</p> <p>Adjust the square to obtain similar readings at both ends of its measuring length.</p> <p>Table in central position:</p> <p>a) cross-slide (Y-axis) locked,</p> <p>b) table (X-axis) locked.</p> <p>If the spindle can be locked, the dial gauge may be mounted on it. If the spindle cannot be locked, the dial gauge shall be placed on a fixed part of the spindle head.</p>	

<p>Object</p>	<p>G2</p>
<p>Checking of squareness between the transverse cross-slide movement (Y-axis) and the longitudinal movement (X-axis).</p>	
<p>Diagram</p> <p>The diagram consists of two cross-sectional views of a machine table and spindle head assembly, labeled 1) and 2). In view 1), a straightedge is placed on the table surface, and a square is placed against it. The spindle head is positioned above the straightedge. A horizontal double-headed arrow below the table indicates longitudinal movement (X-axis). In view 2), the spindle head is moved vertically (Y-axis), as indicated by a vertical double-headed arrow to its right. Both views include coordinate axes: X pointing left and Y pointing down.</p>	
<p>Tolerance</p> <p>0,02 for a measuring length of 300</p>	<p>Measured deviation</p>
<p>Measuring instruments Straightedge, dial gauge and square</p> <p style="text-align: center; color: red; font-weight: bold;">iTeh STANDARD PREVIEW (standards.iteh.ai)</p>	
<p>Observations and references to ISO 230-1:1996 ISO 1984-2:2001 5.522.4</p> <p>Spindle-head slide (Z-axis) locked.</p> <p>1) The straightedge shall be set parallel to the longitudinal table movement (X-axis); then the square shall be placed against the straightedge. The table shall then be locked in the central position. This test can also be performed without the straightedge, aligning the long arm of the square parallel to the X-axis.</p> <p>2) The transverse cross-slide movement (Y-axis) shall then be checked.</p> <p>If the spindle can be locked, the dial gauge may be mounted on it. If the spindle cannot be locked, the dial gauge shall be placed on a fixed part of the spindle head.</p>	

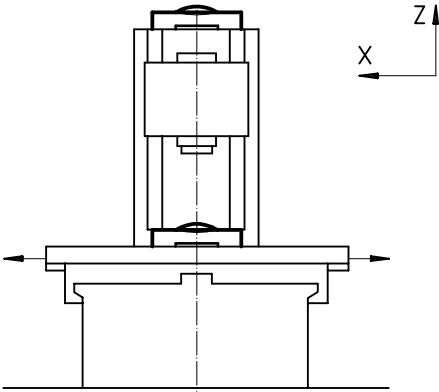
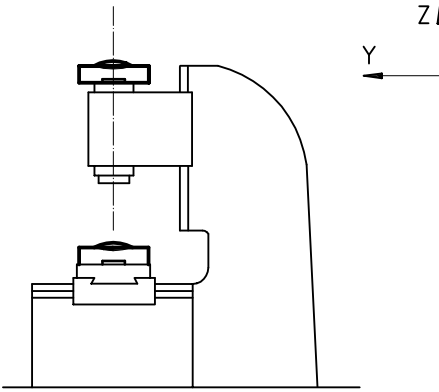
Object		G3
<p>Checking of angular deviation of the table in its longitudinal movement (X-axis):</p> <p>a) in the vertical ZX-plane (pitch, EBX);</p> <p>b) in the vertical YZ-plane (roll, EAX).</p>		
Diagram <div style="display: flex; justify-content: space-around; align-items: center;"> <div style="text-align: center;">  <p>a)</p> </div> <div style="text-align: center;">  <p>b)</p> </div> </div>		
Tolerance a) $X \leq 1\ 000$ 0,06/1 000 (or 60 μrad or 12 ") $X > 1\ 000$ 0,10/1 000 (100 μrad or 20 ") b) 0,03/1 000 (or 30 microrad or 6 ")	Measured deviation For X = ... a) b)	
Measuring instruments Precision level		
Observations and references to ISO 230-1:1996 The level shall be placed in the centre of the table a) longitudinally; b) transversely. When the X-axis motion causes an angular movement of both spindle head and work-holding table, differential measurements of the two angular movements shall be made and this shall be stated. The reference level (when used) shall be located on the column or the spindle head and the spindle head shall be in the middle of its travel range. Measurements shall be taken at a number of positions equally spaced (200 mm or 250 mm) along the travel direction. The difference between the maximum and the minimum readings of both directions of movement shall not exceed the tolerance.		