



Designation: D 6484/D 6484M – 04

Standard Test Method for Open-Hole Compressive Strength of Polymer Matrix Composite Laminates¹

This standard is issued under the fixed designation D 6484/D 6484M; the number immediately following the designation indicates the year of original adoption or, in the case of revision, the year of last revision. A number in parentheses indicates the year of last reapproval. A superscript epsilon (ϵ) indicates an editorial change since the last revision or reapproval.

1. Scope

1.1 This test method determines the open-hole compressive strength of multidirectional polymer matrix composite laminates reinforced by high-modulus fibers. The composite material forms are limited to continuous-fiber or discontinuous-fiber (tape or fabric, or both) reinforced composites in which the laminate is balanced and symmetric with respect to the test direction. The range of acceptable test laminates and thicknesses are described in 8.2.1.

1.2 The values stated in either SI units or inch-pound units are to be regarded separately as standard. Within the text the inch-pound units are shown in brackets. The values stated in each system are not exact equivalents; therefore, each system must be used independently of the other. Combining values from the two systems may result in nonconformance with the standard.

1.3 *This standard does not purport to address all of the safety concerns, if any, associated with its use. It is the responsibility of the user of this standard to establish appropriate safety and health practices and determine the applicability of regulatory limitations prior to use.*

2. Referenced Documents

2.1 ASTM Standards:²

- D 792 Test Methods for Density and Specific Gravity (Relative Density) of Plastics by Displacement
- D 883 Terminology Relating to Plastics
- D 2584 Test Method for Ignition Loss of Cured Reinforced Resins

¹ This test method is under the jurisdiction of ASTM Committee D30 on Composite Materials and is the direct responsibility of Subcommittee D30.05 on Structural Test Methods.

Current edition approved March 1, 2004. Published April 2004. Originally approved in 1999. Last previous edition approved in 1999 as D 6484/D 6484M – 99¹.

² For referenced ASTM standards, visit the ASTM website, www.astm.org, or contact ASTM Customer Service at service@astm.org. For *Annual Book of ASTM Standards* volume information, refer to the standard's Document Summary page on the ASTM website.

- D 2734 Test Method for Void Content of Reinforced Plastics
- D 3039/D 3039M Test Method for Tensile Properties of Polymer Matrix Composite Materials
- D 3171 Test Method for Constituent Content of Composite Materials
- D 3878 Terminology for Composite Materials
- D 5229/D 5229M Test Method for Moisture Absorption Properties and Equilibrium Conditioning of Polymer Matrix Composite Materials
- D 5687/D 5687M Guide for Preparation of Flat Composite Panels with Processing Guidelines for Specimen Preparation
- E 4 Practices for Force Verification of Testing Machines
- E 6 Terminology Relating to Methods of Mechanical Testing
- E 83 Practice for Verification and Classification of Extensometers
- E 122 Practice for Calculating Sample Size to Estimate, With a Specified Tolerable Error, the Average for a Characteristic of a Lot or Process
- E 177 Practice for Use of the Terms Precision and Bias in ASTM Test Methods
- E 456 Terminology Relating to Quality and Statistics
- E 691 Practice for Conducting an Interlaboratory Study to Determine the Precision of a Test Method
- E 1309 Guide for Identification of Fiber-Reinforced Polymer-Matrix Composite Materials in Databases
- E 1434 Guide for Recording Mechanical Test Data of Fiber-Reinforced Composite Materials in Databases
- E 1471 Guide for Identification of Fibers, Fillers, and Core Materials in Computerized Material Property Databases

3. Terminology

3.1 *Definitions*—Terminology D 3878 defines terms relating to high-modulus fibers and their composites. Terminology D 883 defines terms relating to plastics. Terminology E 6 defines terms relating to mechanical testing. Terminology E 456 and Practice E 177 define terms relating to statistics. In

the event of a conflict between terms, Terminology **D 3878** shall have precedence over the other terminologies.

3.2 Definitions of Terms Specific to This Standard:

NOTE 1—If the term represents a physical quantity, its analytical dimensions are stated immediately following the term (or letter symbol) in fundamental dimension form, using the following ASTM standard symbology for fundamental dimensions, shown within square brackets: [*M*] for mass, [*L*] for length, [*T*] for time, [θ] for thermodynamic temperature, and [*nd*] for nondimensional quantities. Use of these symbols is restricted to analytical dimensions when used with square brackets, as the symbols may have other definitions when used without the brackets.

3.2.1 *nominal value, n*—a value, existing in name only, assigned to a measurable property for the purpose of convenient designation. Tolerances may be applied to a nominal value to define an acceptable range for the property.

3.2.2 *principal material coordinate system, n*—a coordinate system with axes that are normal to the planes of symmetry inherent to a material.

3.2.3 *Discussion*—Common usage, at least for Cartesian axes (123, *xyz*, and so forth), generally assigns the coordinate system axes to the normal directions of planes of symmetry in order that the highest property value in a normal direction (for elastic properties, the axis of greatest stiffness) would be 1 or *x*, and the lowest (if applicable) would be 3 or *z*. Anisotropic materials do not have a principal material coordinate system due to the total lack of symmetry, while, for isotropic materials, any coordinate system is a principal material coordinate system. In laminated composites, the principal material coordinate system has meaning only with respect to an individual orthotropic lamina. The related term for laminated composites is “reference coordinate system.”

3.2.4 *reference coordinate system, n*—a coordinate system for laminated composites used to define ply orientations. One of the reference coordinate system axes (normally the Cartesian *x*-axis) is designated the reference axis, assigned a position, and the ply principal axis of each ply in the laminate is referenced relative to the reference axis to define the ply orientation for that ply.

3.2.5 *specially orthotropic, adj*—a description of an orthotropic material as viewed in its principal material coordinate system. In laminated composites, a specially orthotropic laminate is a balanced and symmetric laminate of the $[0_i/90_j]_{ns}$ family as viewed from the reference coordinate system, such that the membrane-bending coupling terms of the laminate constitutive relation are zero.

3.3 Symbols:

- A*—cross-sectional area of a coupon
- CV*—coefficient of variation statistic of a sample population for a given property (in percent)
- B_z —edgewise percent bending
- D*—hole diameter
- h*—coupon thickness
- n*—number of coupons per sample population
- N*—number of plies in laminate under test
- F_x^{ohcu} —ultimate open hole (notched) compressive strength in the test direction
- P_{max} —maximum force carried by test coupon before failure
- r*—95 % repeatability confidence limit, equal to 2.8 times the repeatability standard deviation

R—95 % reproducibility confidence limit, equal to 2.8 times the reproducibility standard deviation

S_{n-1} —standard deviation statistic of a sample population for a given property

S_r —repeatability (within laboratory precision) standard deviation, calculated in accordance with Practice **E 691**

S_R —reproducibility (between laboratory precision) standard deviation, calculated in accordance with Practice **E 691**

w—coupon width

x_1 —test result for an individual coupon from the sample population for a given property

\bar{x} —mean or average (estimate of mean) of a sample population for a given property

σ —normal stress

4. Summary of Test Method

4.1 A uniaxial compression test of a balanced, symmetric laminate is performed with a centrally located hole. Edge-mounted extensometer displacement transducers are optional. Ultimate strength is calculated based on the gross cross-sectional area, disregarding the presence of the hole. While the hole causes a stress concentration and reduced net section, it is common aerospace practice to develop notched design allowable strengths based on gross section stress to account for various stress concentrations (fastener holes, free edges, flaws, damage, and so forth) not explicitly modeled in the stress analysis.

4.2 The test specimen is face-supported in a multi-piece bolted support fixture. Two acceptable test procedures are provided. In Procedure A, the specimen/fixture assembly is clamped in hydraulic wedge grips. The force is transmitted by shear into the support fixture and then is transmitted by shear into the test specimen. In Procedure B, the specimen/fixture assembly is placed between flat platens, such that the specimen and fixture are end-loaded. The portion of the force initially transferred into the support fixture is transmitted by shear into the test specimen.

4.3 The only acceptable failure mode for ultimate open-hole compressive strength is one which passes through the hole in the test specimen.

5. Significance and Use

5.1 This test method is designed to produce notched compressive strength data for structural design allowables, material specifications, research and development, and quality assurance. Factors that influence the notched compressive strength and shall therefore be reported include the following: material, methods of material fabrication, accuracy of lay-up, laminate stacking sequence and overall thickness, specimen geometry, specimen preparation (especially of the hole), specimen conditioning, environment of testing, specimen alignment and gripping, loading procedure, speed of testing, void content, and volume percent reinforcement. Properties that may be derived from this test method include open-hole (notched) compressive strength (OHC).

6. Interferences

6.1 *Hole Preparation*—Because of the dominating presence of the notch, and the lack of need to measure the material

response, results from this test method are relatively insensitive to parameters that would be of concern in an unnotched compressive property test. However, since the notch dominates the strength, consistent preparation of the hole, without damage to the laminate, is important to meaningful results. Damage caused by hole preparation will affect strength results. Some types of damage, such as longitudinal splitting and delamination, can blunt the stress concentration caused by the hole, increasing the force-carrying capacity of the coupon and the calculated strength.

6.2 Geometry—Results are affected by the ratio of specimen width to hole diameter; this ratio should be maintained at 6, unless the experiment is investigating the influence of this ratio. Results may also be affected by the ratio of hole diameter to thickness; the preferred ratio is the range from 1.5 to 3.0 unless the experiment is investigating the influence of this ratio. Results may also be affected by the ratio of ungripped specimen length to specimen width; this ratio should be maintained at 2.7, unless the experiment is investigating the influence of this ratio.

6.3 Support Fixture—Results are affected by the amount of lateral pressure applied to the test specimen by the support fixture. Sources of variation in this lateral pressure include fixture bolt torque, hydraulic gripping pressure, and fixture shimming choices, and should be controlled and reported as required in the Procedure and Report sections. The support fixture can inhibit the growth of delamination damage by inhibiting out-of-plane deformation beyond the cutout, and by relieving force from the specimen via friction effects. This may result in non-conservative data.

6.4 Material Orthotropy—The degree of laminate orthotropy strongly affects the failure mode and measured OHC strength. Valid OHC strength results should only be reported when appropriate failure modes are observed, in accordance with 11.9.

6.5 Thickness Scaling—Thick composite structures do not necessarily fail at the same strengths as thin structures with the same laminate orientation (that is, strength does not always scale linearly with thickness). Thus, data gathered using this test method may not translate directly into equivalent thickness properties.

6.6 Type of Loading—Differences in force versus crosshead displacement and force versus extensometer strain response may be observed when comparing hydraulic grip-loaded specimens with end-loaded specimens. Hydraulic grip-loaded data typically exhibit linear behavior at the onset of loading. At high force levels, some nonlinear behavior may be observed due to grip slippage. End-loaded data typically display some initial nonlinear behavior at low force levels, due to seating of the specimen/fixture assembly underneath the load platens, but then exhibit linear behavior to failure.

7. Apparatus

7.1 Micrometers—The micrometer(s) shall use a 4- to 5-mm [0.16- to 0.20-in.] nominal diameter ball-interface on irregular surfaces such as the bag-side of a laminate, and a flat anvil interface on machined edges or very smooth-tooled surfaces. The accuracy of the instrument(s) shall be suitable for reading to within 1 % of the sample width and thickness. For typical

specimen geometries, an instrument with an accuracy of $\pm 25 \mu\text{m}$ [$\pm 0.001 \text{ in.}$] is desirable for thickness measurement, while an instrument with an accuracy of $\pm 76 \mu\text{m}$ [$\pm 0.003 \text{ in.}$] is desirable for width measurement. Additionally, a micrometer or gage capable of determining the hole diameter to $\pm 25 \mu\text{m}$ [$\pm 0.001 \text{ in.}$] is required.

7.2 Support Fixture—The fixture is a face-supported compressive test fixture as shown in Fig. 1. The fixture consists of two short-grip/long-grip assemblies, two support plates, and stainless steel shims as required to maintain a nominally zero (0.00- to 0.12-mm [0.000- to 0.005-in.] tolerance) gap between support plates and long grips. If this gap does not meet the minimum requirement, shim the contact area between the support plate and the short grip with stainless steel shim stock. If the gap is too large, shim between the support plate and the long grip, holding the shim stock on the support plate with tape. Fig. 2 shows shim requirements. The fixture should be checked for conformity to engineering drawings. Each short-grip/long-grip assembly is line-drilled as shown in Figs. 3 and 4 and must be used as a matched set. The threading of the support plate is optional. Standard test specimens are 36 by 300 mm [1.5 by 12 in.]. In Procedure A, the fixture is hydraulically gripped on each end and the compressive force is transmitted by means of friction through the fixture and into the test specimen. In Procedure B, the fixture is placed between flat platens and loaded in compression at each end; force introduced into the fixture is transmitted by means of friction into the test specimen. A cutout exists on both faces of the fixture for a thermocouple, fastener, or extensometer, if required by the requesting organization. The long and short fixtures have an undercut along the corner of the specimen grip area so that specimens are not required to be chamfered and to avoid damage caused by the radius. The fixtures also allow a slight clearance between the fixture and the gage section of the specimen, in order to minimize grip failures and friction effects.

7.2.1 Support Fixture Details—The detailed drawings for manufacturing the support fixture are contained in Figs. 5-12. An optional threaded support plate is shown in Figs. 13 and 14, to be used instead of the support plate shown in Figs. 11 and 12 and the nuts called out in Fig. 1. Other fixtures that meet the requirements of this section may be used (for example, MTS Open Hole Compressive Fixture Model 605.21A or Wyoming Test Fixtures, Inc. Models CU-OH and WTF-OH). The following general notes apply to these figures:

7.2.1.1 Machine surfaces to a 3.2 [125] finish unless otherwise specified.

7.2.1.2 Break all edges.

7.2.1.3 Specimen-gripping area shall be thermal sprayed using high-velocity oxygen fueled (HVOF), electrospark deposition (ESD), or equivalent process.

7.2.1.4 The test fixture may be made of low-carbon steel for ambient temperature testing. For non-ambient environmental conditions, the recommended fixture material is a nonheat-treated ferritic or precipitation-hardened stainless steel (heat treatment for improved durability is acceptable but not required).

METRIC HARDWARE
 NA0036-060050 BOLT (4)
 NA0179B-060 WASHER (8+)
 (# AS REQ'D)
 NA0033-060M NUT (4)
 (OR EQUIVALENT)
 OR
 FOR THREADED PLATES
 NA0036-060045 BOLT (4)
 NA0179B-060 WASHER (4)
 (OR EQUIVALENT)

US CUSTOMARY HARDWARE
 NAS 6605-32 BOLT (4)
 NAS 1587-5C WASHER (8+)
 (# AS REQ'D.)
 NAS 1804-5 NUT (4)
 [OR EQUIVALENT]
 OR
 FOR THREADED PLATES
 NAS6605-28 BOLT (4)
 NAS 1587-5C WASHER (4)
 [OR EQUIVALENT]

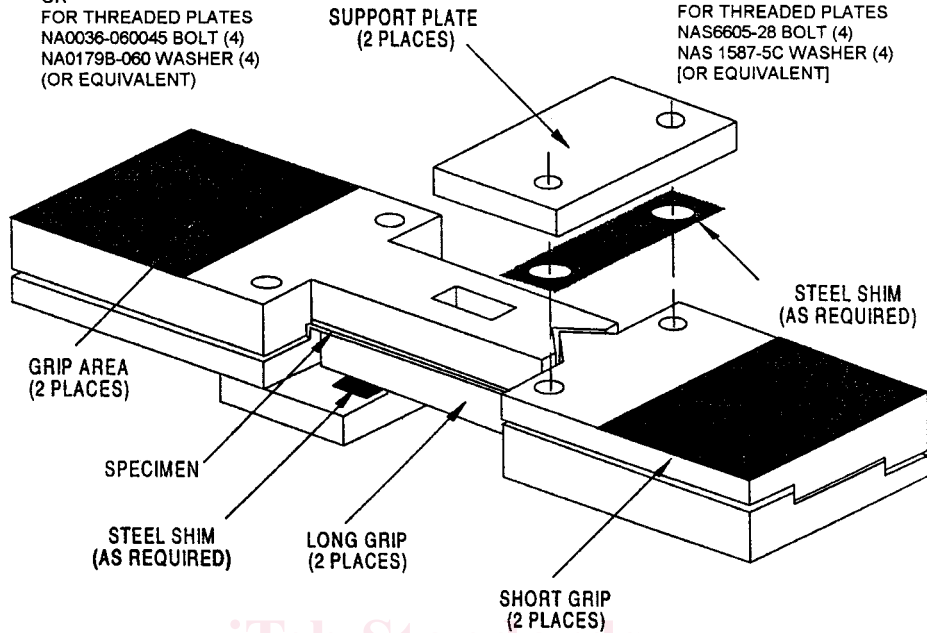

FIG. 1 Support Fixture Assembly

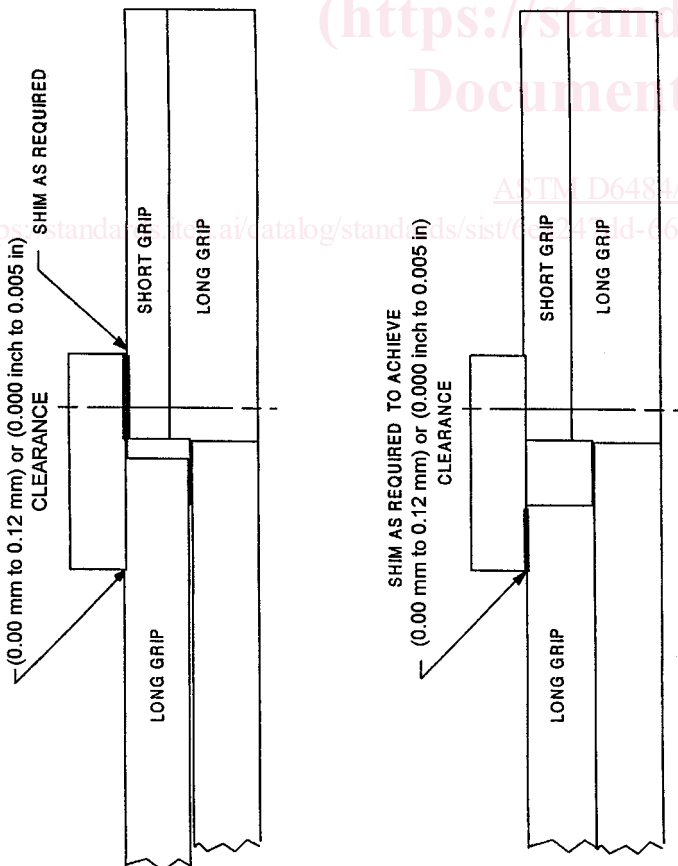

FIG. 2 Support Fixture—Shim Requirements

7.2.1.5 Additional fasteners may be installed in the gripping area (shown in Figs. 3 and 4) when using Procedure B. The presence of such fasteners is not required to perform an end-loaded test successfully. However, they can be beneficial in suppressing unacceptable failure modes (such as end failures) in certain circumstances (high temperature testing, for example) by ensuring that the specimen is well-supported by the fixture.

NOTE 2—Experience has shown that fixtures may be damaged in use, thus periodic reinspection of the fixture dimensions and tolerances is important.

7.3 Testing Machine—The testing machine shall be in accordance with Practices E 4 and shall satisfy the following requirements:

7.3.1 Testing Machine Configuration—The testing machine shall have both an essentially stationary head and a movable head. A short loading train, and either rigidly mounted hydraulic grips or flat end-loading platens, shall be used.

7.3.2 Grips—If Procedure A is used, each head of the testing machine shall be capable of holding one end of the test assembly so that the direction of force applied to the specimen is coincident with the longitudinal axis of the specimen. Hydraulic wedge grips shall apply sufficient lateral pressure to prevent slippage between the grip face and the support fixture.

7.3.3 Flat Platens—If Procedure B is used, the test machine shall be mounted with well-aligned, fixed (as opposed to spherical seat) flat platens. The platen surfaces shall be parallel within 0.03 mm [0.001 in.] across the test fixture base length of 80 mm [3.0 in]. If the platens are not sufficiently hardened, or simply to protect the platen surfaces, a hardened plate (with

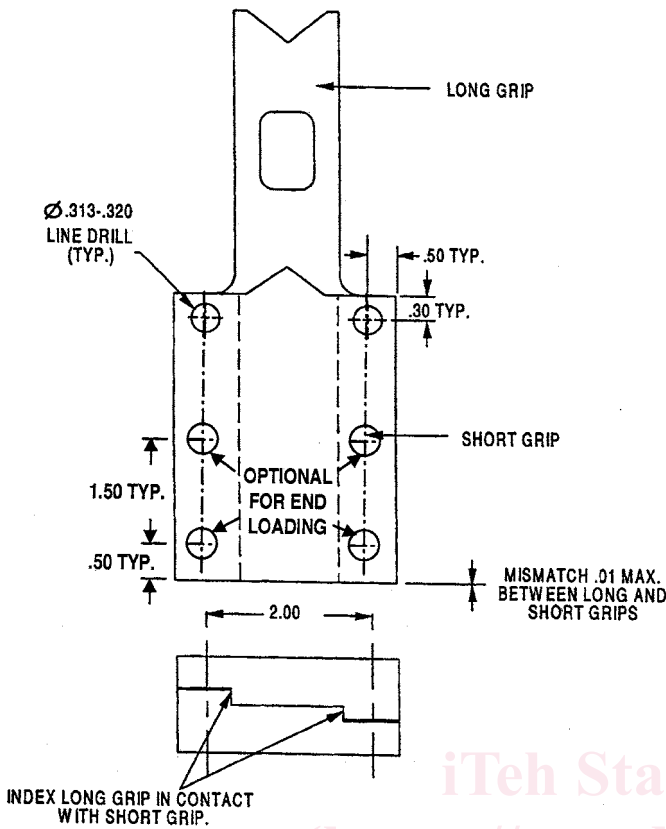

- NOTE 1—
- (a) All dimensions in inches.
 - (b) The long grip and short grip should be part marked with a unique test fixture assembly identification.
 - (c) Tolerance except as noted is linear ± 0.01 in.

FIG. 3 Support Fixture—Line Drilling Details (Inch-Pound Version)

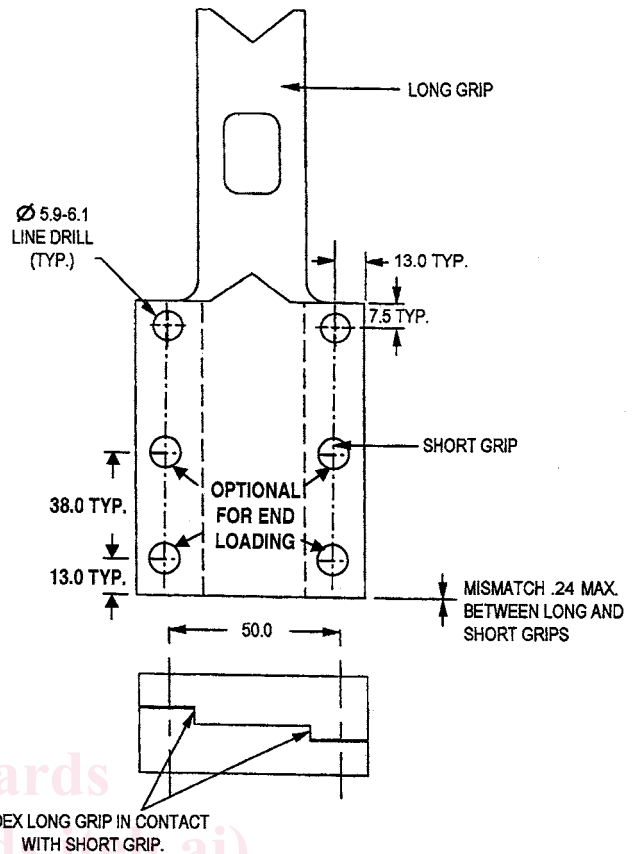

- NOTE 1—
- (a) All dimensions in mm.
 - (b) The long grip and short grip should be part marked with a unique test fixture assembly identification.
 - (c) Tolerance except as noted is linear ± 0.24 mm.

FIG. 4 Support Fixture—Line Drilling Details (SI Version)

parallel surfaces) can be inserted between each end of the fixture and the corresponding platen. A rectangle should be drawn on the center of the lower platen, to help center the test fixture between the platens.

7.3.4 *Drive Mechanism*—The testing machine drive mechanism shall be capable of imparting to the movable head a controlled velocity with respect to the stationary head. The velocity of the movable head shall be capable of being regulated in accordance with 11.3.

7.3.5 *Load Indicator*—The testing machine load-sensing device shall be capable of indicating the total force being carried by the test specimen. This device shall be essentially free from inertia lag at the specified rate of testing and shall indicate the force with an accuracy over the force range(s) of interest of within $\pm 1\%$ of the indicated value.

7.3.6 *Extensometers*—The extensometer gage length shall be 25 mm [1.0 in.]. Extensometers shall satisfy, at a minimum, Practice E 83, Class B-1 requirements for the strain range of interest, and shall be calibrated over that range in accordance with Practice E 83. The extensometers shall be essentially free of inertia lag at the specified speed of testing.

7.4 *Conditioning Chamber*—When conditioning materials at non-laboratory environments, a temperature/vapor-level

controlled environmental conditioning chamber is required that shall be capable of maintaining the required temperature to within $\pm 3^\circ\text{C}$ [$\pm 5^\circ\text{F}$] and the required relative humidity level to within $\pm 3\%$. Chamber conditions shall be monitored either on an automated continuous basis or on a manual basis at regular intervals.

7.5 *Environmental Test Chamber*—An environmental test chamber is required for test environments other than ambient testing laboratory conditions. This chamber shall be capable of maintaining the gage section of the test specimen at the required test environment during the mechanical test.

8. Sampling and Test Specimens

8.1 *Sampling*—Test at least five specimens per test condition unless valid results can be gained through the use of fewer specimens, as in the case of a designed experiment. For statistically significant data, consult the procedures outlined in Practice E 122. Report the method of sampling.

8.2 Geometry:

8.2.1 *Stacking Sequence*—The standard tape and fabric laminates shall have multidirectional fiber orientations (fibers shall be oriented in a minimum of two directions), and

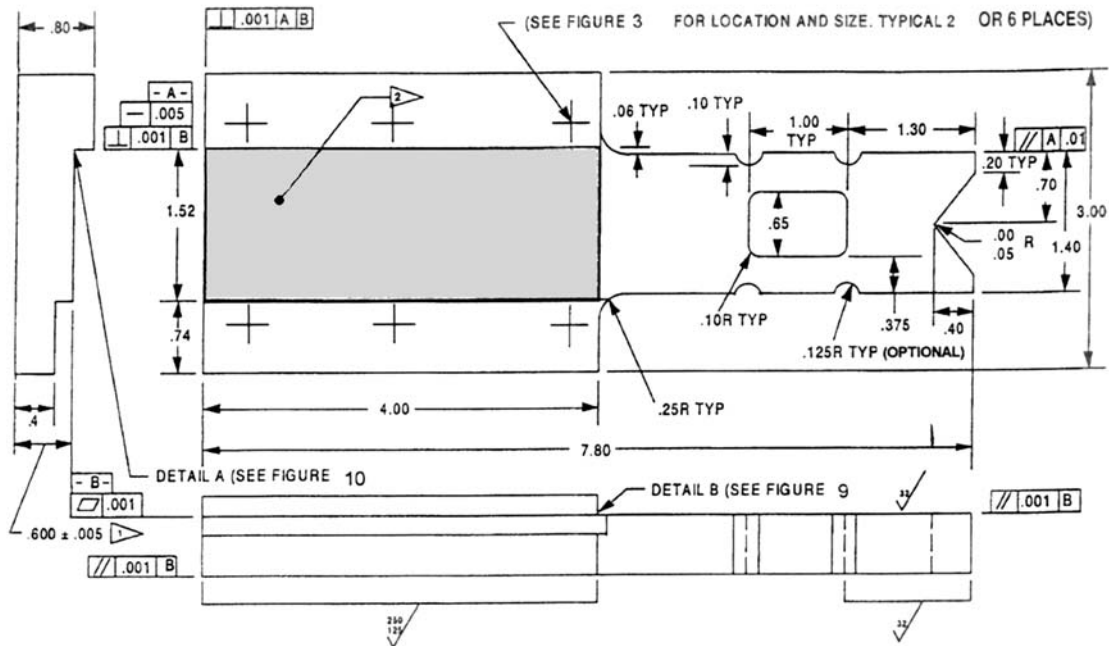

NOTE 1—See 7.2.1 for general notes.

(Flag symbol 1) For existing fixtures this dimension is 0.60 ± 0.02 ; however, all four fittings must be within ± 0.005 of each other.

(Flag symbol 2) Thermal spray surface using either high velocity oxygen fueled (HVOF) process or electrospark deposition (ESD) process.

FIG. 5 Support Fixture—Long Grip Details (Inch-Pound Version)

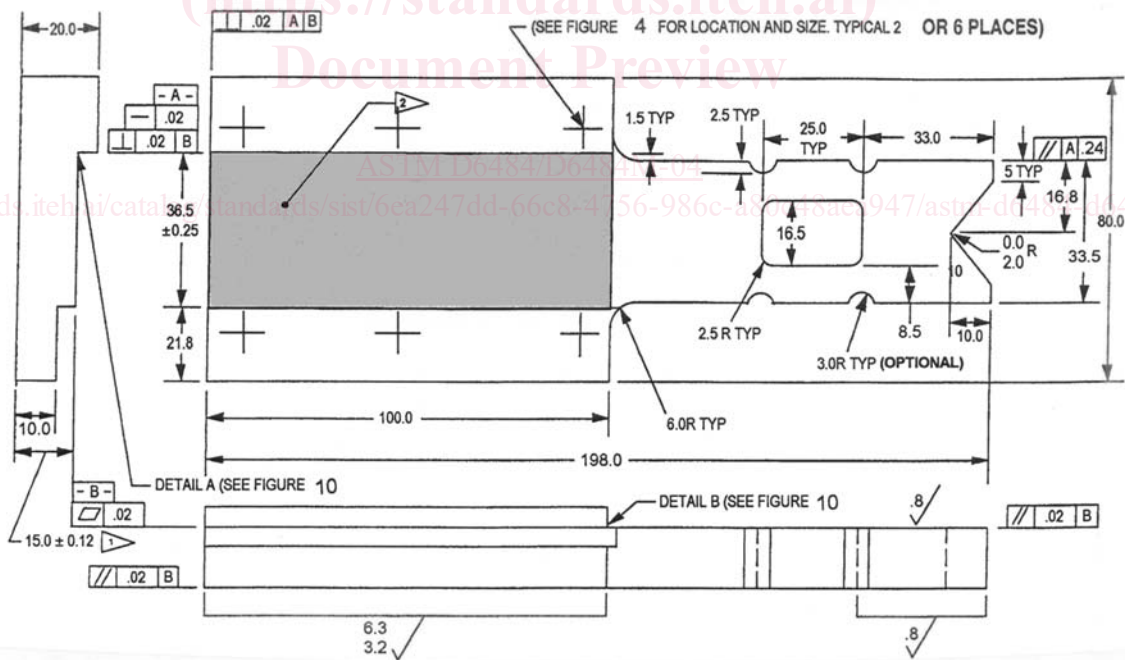

NOTE 1—See 7.2.1 for general notes.

(Flag symbol 1) For existing fixtures this dimension is 15 ± 0.5 ; however, all four fittings must be within ± 0.12 of each other.

(Flag symbol 2) Thermal spray surface using either high velocity oxygen fueled (HVOF) process or electrospark deposition (ESD) process.

FIG. 6 Support Fixture—Long Grip Details (SI Version)

balanced and symmetric stacking sequences. The nominal thickness shall be 4 mm [0.160 in.], with a permissible range