

INTERNATIONAL
STANDARD

ISO/ASTM
51310

First edition
2002-03-15

Practice for use of a radiochromic optical waveguide dosimetry system

Pratique de l'utilisation d'un système dosimétrique à guide
d'ondes optiques radiochromiques
iTeh STANDARD PREVIEW
(standards.iteh.ai)

ISO/ASTM 51310:2002

<https://standards.iteh.ai/catalog/standards/sist/5a0bed79-f0c0-42c8-a535-b57440137521/iso-astm-51310-2002>



Reference number
ISO/ASTM 51310:2002(E)

© ISO/ASTM International 2002

PDF disclaimer

This PDF file may contain embedded typefaces. In accordance with Adobe's licensing policy, this file may be printed or viewed but shall not be edited unless the typefaces which are embedded are licensed to and installed on the computer performing the editing. In downloading this file, parties accept therein the responsibility of not infringing Adobe's licensing policy. Neither the ISO Central Secretariat nor ASTM International accepts any liability in this area.

Adobe is a trademark of Adobe Systems Incorporated.

Details of the software products used to create this PDF file can be found in the General Info relative to the file; the PDF-creation parameters were optimized for printing. Every care has been taken to ensure that the file is suitable for use by ISO member bodies and ASTM members. In the unlikely event that a problem relating to it is found, please inform the ISO Central Secretariat or ASTM International at the addresses given below.

iTeh STANDARD PREVIEW
(standards.iteh.ai)

[ISO/ASTM 51310:2002](https://standards.iteh.ai/catalog/standards/sist/5a0bed79-f0c0-42c8-a535-b57440137521/iso-astm-51310-2002)

<https://standards.iteh.ai/catalog/standards/sist/5a0bed79-f0c0-42c8-a535-b57440137521/iso-astm-51310-2002>

© ISO/ASTM International 2002

All rights reserved. Unless otherwise specified, no part of this publication may be reproduced or utilized in any form or by any means, electronic or mechanical, including photocopying and microfilm, without permission in writing from either ISO at the address below or ISO's member body in the country of the requester. In the United States, such requests should be sent to ASTM International.

ISO copyright office
Case postale 56 • CH-1211 Geneva 20
Tel. +41 22 749 01 11
Fax +41 22 749 09 47
E-mail copyright@iso.ch
Web www.iso.ch

ASTM International, 100 Barr Harbor Drive, PO Box C700,
West Conshohocken, PA 19428-2959, USA
Tel. +610 832 9634
Fax +610 832 9635
E-mail khooper@astm.org
Web www.astm.org

Printed in the United States

Contents	Page
1 Scope	1
2 Referenced documents	1
3 Terminology	1
4 Significance and use	2
5 Apparatus	2
6 Performance check of instrumentation	2
7 Calibration of the dosimetry system	3
8 Procedure	3
9 Characterization of each batch of dosimeters	3
10 Application of dosimetry system	4
11 Minimum documentation	4
12 Measurement uncertainty	4
13 Keywords	4
Bibliography	5
Figure 1 Block diagram of the instrument described in section 5	2

iTech STANDARD PREVIEW
(standards.itech.ai)

[ISO/ASTM 51310:2002](https://standards.itech.ai/catalog/standards/sist/5a0bed79-f0c0-42c8-a535-b57440137521/iso-astm-51310-2002)

<https://standards.itech.ai/catalog/standards/sist/5a0bed79-f0c0-42c8-a535-b57440137521/iso-astm-51310-2002>

Foreword

ISO (the International Organization for Standardization) is a worldwide federation of national standards bodies (ISO member bodies). The work of preparing International Standards is normally carried out through ISO technical committees. Each member body interested in a subject for which a technical committee has been established has the right to be represented on that committee. International organizations, governmental and non-governmental, in liaison with ISO, also take part in the work. ISO collaborates closely with the International Electrotechnical Commission (IEC) on all matters of electrotechnical standardization.

Draft International Standards adopted by the technical committees are circulated to the member bodies for voting. Publication as an International Standard requires approval by at least 75% of the member bodies casting a vote.

ASTM International is one of the world's largest voluntary standards development organizations with global participation from affected stakeholders. ASTM technical committees follow rigorous due process balloting procedures.

A pilot project between ISO and ASTM International has been formed to develop and maintain a group of ISO/ASTM radiation processing dosimetry standards. Under this pilot project, ASTM Subcommittee E10.01, Dosimetry for Radiation Processing, is responsible for the development and maintenance of these dosimetry standards with unrestricted participation and input from appropriate ISO member bodies.

Attention is drawn to the possibility that some of the elements of this International Standard may be the subject of patent rights. Neither ISO nor ASTM International shall be held responsible for identifying any or all such patent rights.

International Standard ISO/ASTM 51310 was developed by ASTM Committee E10, Nuclear Technology and Applications, through Subcommittee E10.01, and by Technical Committee ISO/TC 85, Nuclear Energy.



Standard Practice for Use of a Radiochromic Optical Waveguide Dosimetry System¹

This standard is issued under the fixed designation ISO/ASTM 51310; the number immediately following the designation indicates the year of original adoption or, in the case of revision, the year of last revision.

1. Scope

1.1 This practice covers the handling, testing, and procedure for using a radiochromic optical waveguide dosimetry system to measure absorbed dose in materials irradiated by photons in terms of absorbed dose in water.

1.2 This practice applies to radiochromic optical waveguide dosimeters that can be used within part or all of the specified ranges as follows:

1.2.1 The absorbed dose range is from 1 to 10 000 Gy for photons.

1.2.2 The absorbed dose rate is from 0.001 to 1000 Gy/s.

1.2.3 The radiation energy range for photons is from 0.1 to 10 MeV.

1.2.4 The irradiation temperature range is from -78 to +60°C.

1.3 *This standard does not purport to address all of the safety concerns, if any, associated with its use. It is the responsibility of the user of this standard to establish appropriate safety and health practices and determine the applicability of regulatory limitations prior to use.*

2. Referenced Documents

2.1 ASTM Standards:

E 170 Terminology Relating to Radiation Measurements and Dosimetry²

E 177 Practice for Use of the Terms Precision and Bias in ASTM Test Methods³

E 178 Practice for Dealing with Outlying Observations³

E 275 Practice for Describing and Measuring Performance of Ultraviolet, Visible, and Near Infrared Spectrophotometers⁴

E 456 Terminology Relating to Quality and Statistics²

E 666 Practice for Calculating Absorbed Dose from Gamma or X Radiation²

E 668 Practice for the Application of Thermoluminescence-Dosimetry (TLD) Systems for Determining Absorbed Dose in Radiation-Hardness Testing of Electronic Devices²

E 925 Practice for the Periodic Calibration of Narrow Band-Pass Spectrophotometers⁴

E 958 Practice for Measuring Practical Spectral Bandwidth of Ultraviolet-Visible Spectrophotometers⁴

E 1026 Practice for Using the Fricke Reference Standard Dosimetry System²

2.2 ISO/ASTM Standards:

51204 Practice for Dosimetry in Gamma Irradiation Facilities for Food Processing²

51205 Practice for Use of a Ceric-Cerous Sulfate Dosimetry System²

51261 Guide for Selection and Calibration of Dosimetry Systems for Radiation Processing²

51275 Practice for Use of a Radiochromic Film Dosimetry System²

51276 Practice for Use of a Polymethylmethacrylate Dosimetry System²

2.3 International Commission on Radiation Units and Measurements (ICRU) Reports:⁵

ICRU Report 14 Radiation Dosimetry: X-Rays and Gamma Rays with Maximum Photon Energies Between 0.6 and 50 MeV

ICRU Report 17 Radiation Dosimetry: X-Rays Generated at Potentials of 5 to 150 kV

ICRU Report 34 The Dosimetry of Pulsed Radiation

ICRU Report 60 Radiation Quantities and Units

3. Terminology

3.1 Definitions:

3.1.1 *analysis wavelength*—wavelength used in a spectrophotometric instrument for the measurement of optical absorbance.

3.1.2 *calibration curve*—graphical representation of the dosimetry system's response function.

3.1.3 *dosimeter batch*—quantity of dosimeters made from a specific mass of material with uniform composition, fabricated in a single production run under controlled, consistent conditions and having a unique identification code.

3.1.4 *dosimetry system*—a system used for determining absorbed dose, consisting of dosimeters, measurement instruments and their associated reference standards, and procedures for the system's use.

3.1.5 *measurement quality assurance plan*—a documented program for the measurement process that ensures on a

¹ This guide is under the jurisdiction of ASTM Committee E10 on Nuclear Technology and Applications and is the direct responsibility of Subcommittee E10.01 on Dosimetry for Radiation Processing, and is also under the jurisdiction of ISO/TC 85/WG 3.

Current edition approved Jan. 22, 2002. Published March 15, 2002. Originally published as ASTM E 1310-89. Last previous ASTM edition E 1310-98^{e1}. ASTM E 1310-94 was adopted by ISO in 1998 with the intermediate designation ISO 15559:1998(E). The present International Standard ISO/ASTM 51310:2002(E) is a revision of ISO 15559.

² *Annual Book of ASTM Standards*, Vol 12.02.

³ *Annual Book of ASTM Standards*, Vol 14.02.

⁴ *Annual Book of ASTM Standards*, Vol 03.06.

⁵ Available from the International Commission on Radiation Units and Measurements, 7910 Woodmont Ave., Suite 800, Bethesda, MD 20814, U.S.A.



continuing basis that the overall uncertainty meets the requirements of the specific application. This plan requires traceability to, and consistency with, nationally or internationally recognized standards.

3.1.6 *net response*, ΔR —the radiation-induced change in the relationship of measured absorbance at a specific wavelength determined by subtracting the pre-irradiation response, R_0 , from the post-irradiation response, R :

$$\Delta R = R - R_0 \quad (1)$$

where:

$$R = \frac{A_\lambda}{A_{\lambda_{ref}}} \quad (2)$$

$$R_0 = \left[\frac{A_\lambda}{A_{\lambda_{ref}}} \right]_0$$

where:

A_λ = optical absorbance at the analysis wavelength, λ ,
and

$A_{\lambda_{ref}}$ = optical absorbance at a reference wavelength, λ_{ref} .

A block diagram of an instrument capable of measuring R or R_0 is shown in Fig. 1.

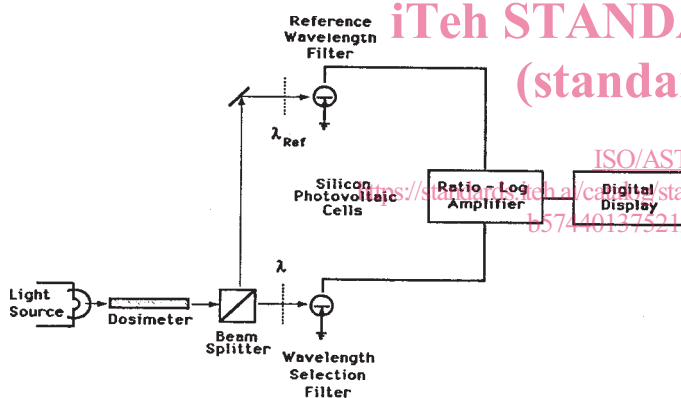

FIG. 1 Block Diagram of the Instrument Described in Section 5

3.1.7 *optical waveguide*—a device that contains an optical path at a high index of refraction relative to the material enclosing the optical path.

3.1.8 *radiochromic optical waveguide*—a specially prepared optical waveguide containing ingredients that undergo an ionizing radiation-induced change in photometric absorbance. This change in absorbance can be related to absorbed dose in water (1, 2).⁶

3.1.9 *reference wavelength*, λ_{ref} —the wavelength selected for comparison with the analysis wavelength. This wavelength is chosen to minimize effects associated with optical coupling and other geometric variations in the dosimeter.

3.1.10 *response function*—mathematical representation of the relationship between dosimeter response and absorbed dose for a given dosimetry system.

⁶ The boldface numbers in parentheses refer to the bibliography at the end of this practice.

3.2 Definitions or other terms used in this standard that pertain to radiation measurement and dosimetry may be found in ASTM Terminology E 170. Definitions in ASTM E 170 are compatible with ICRU 60; that document, therefore, may be used as an alternative reference.

4. Significance and Use

4.1 The radiochromic optical waveguide dosimetry system provides a means of measuring absorbed dose in materials. Under the influence of ionizing radiation, chemical reactions take place in the radiochromic optical waveguide creating and/or modifying optical absorbance bands in the visible region of the spectrum. Optical response is determined at selected wavelengths using the equations in 3.1.6. Examples of appropriate wavelengths for the analysis for specific dosimetry systems are provided by their manufacturers and in Refs (1) through (5).

4.2 In the application of a specific dosimetry system, absorbed dose is determined by use of a calibration curve traceable to national standards.

4.3 The absorbed dose determined is usually specified in water. Absorbed dose in other materials may be determined by applying the conversion factors discussed in ISO/ASTM Guide 51261.

NOTE 1—For a comprehensive discussion of various dosimetry methods applicable to the radiation types and energies discussed in this practice, see ICRU Reports 14, 17, and 34.

4.4 These dosimetry systems commonly are applied in the industrial radiation processing of a variety of products, for example, the sterilization of medical devices and radiation processing of foods (4-6).

5. Apparatus

5.1 The following shall be used to determine absorbed dose with radiochromic optical waveguide dosimetry systems:

5.1.1 *Dosimeters*—A batch or portion of a batch of radiochromic optical waveguide dosimeters.

5.1.2 *Spectrophotometer or Photometer*—An instrument, either a spectrophotometer equipped with a special dosimeter holder and associated coupling optics (see Ref 7 for an example), or a modified photometer (Fig. 1), having documentation covering analysis wavelengths, accuracy of wavelength selection, absorbance determination, spectral bandwidth, and stray light rejection.

5.1.3 *Holder*, to position the dosimeter reproducibly in the measuring light beam.

6. Performance Check of Instrumentation

6.1 Check and document the performance of the photometer or spectrophotometer (see ASTM Practices E 275, E 925, E 958, and E 1026).

6.1.1 When using a photometer, check and document the accuracy of the absorbance scale at intervals not to exceed one month during periods of use, or whenever there are indications of poor performance.

6.1.2 When using a spectrophotometer, check and document the precision and bias of the wavelength scale and absorbance



scale at or near the selected analysis wavelength(s) at intervals not to exceed one month during periods of use, or whenever there are indications of poor performance.

6.1.3 Document the comparison of information obtained in 6.1.1 or 6.1.2 with the original instrument specification to verify adequate performance.

7. Calibration of the Dosimetry System

7.1 Prior to use, the dosimetry system shall be calibrated in accordance with the user's documented procedure that specifies details of the calibration process and quality assurance requirements. This calibration procedure shall be repeated at regular intervals to ensure that the accuracy of the absorbed dose measurement is maintained within required limits. Detailed calibration procedures are provided in ISO/ASTM Guide 51261. A calibration shall be performed for each batch of dosimeters.

7.2 *Calibration of Dosimeters*—Irradiation is a critical component of the calibration of the dosimetry system. Calibration irradiations may be performed in several ways, including irradiating the dosimeters using:

7.2.1 a calibration facility that provides an absorbed dose or an absorbed-dose rate having measurement traceability to nationally or internationally recognized standards, or

7.2.2 an in-house calibration facility that provides an absorbed dose or an absorbed-dose rate having measurement traceability to nationally or internationally recognized standards, or

7.2.3 a production or research irradiation facility together with reference- or transfer-standard dosimeters that have measurement traceability to nationally or internationally recognized standards.

7.3 When the optical waveguide dosimeter is used as a transfer-standard dosimeter, the calibration irradiation may be performed only as stated in 7.2.1, and not as stated in 7.2.2 or 7.2.3.

7.4 *Instrument Calibration*—Calibrations of the individual instruments used in the analysis of the dosimeters shall be verified at periodic intervals. These calibrations shall be traceable to nationally or internationally recognized standards. For example, if an optical absorbance-measuring instrument such as a spectrophotometer or densitometer is used, then appropriate standards shall be used to verify the accuracy of the optical absorbance at a specified wavelength(s). See ASTM Practices E 275, E 925, and E 958.

8. Procedure

8.1 *Examination and Storage Procedure:*

8.1.1 Exposure to ultraviolet (UV) radiation may cause the dosimeter to change color. Perform tests to ensure that the handling and reading environment does not cause measurable color development. If needed, place UV filters over fluorescent lights or windows to reduce color development.

NOTE 2—Dosimeters may be stored in UV-opaque material to further avoid the effects noted in 8.1.1.

8.1.2 Handle the dosimeter along the sides, never at the ends. Handling should be kept to a minimum.

8.1.3 Visually inspect the dosimeters for imperfections (for example, loss of end fittings). Discard any dosimeters that show imperfections.

8.1.4 Identify the dosimeters with an appropriate code that can be related to the manufacturer, type, and batch.

8.1.5 Store the dosimeters in accordance with the manufacturer's written recommendations.

8.2 *Irradiation Procedure:*

8.2.1 Determine the pre-irradiation response, R_0 , for each dosimeter at the selected analysis wavelength(s). This may be done for each dosimeter or by use of an average R_0 determined by reading several dosimeters and documenting the variation, provided this practice meets the precision requirements for the application.

8.2.2 Where necessary, package the dosimeters in a UV-opaque material.

8.2.3 Mark the packaged dosimeters appropriately for identification.

8.2.4 For calibration, use an irradiation facility that meets the requirements of Section 7 and follow the procedures defined in that section.

8.2.5 Irradiate the dosimeters.

NOTE 3—The dosimeters may be irradiated in the product undergoing processing or in a medium of similar composition, or water, of appropriate dimensions so as to approximate electron equilibrium conditions. Such equilibrium conditions may not exist within dosimeters placed throughout the product under actual processing conditions. This particularly is the case near interfaces of different materials. Irradiation under nonequilibrium conditions, such as on the surface of a product package, is often used to monitor the absorbed dose delivered to the product and may be related to the absorbed dose within the product by correction factors under certain conditions. For a detailed discussion of this subject, see ISO/ASTM Guide 51261 and ISO/ASTM Practice 51204.

8.3 *Analysis Procedure:*

8.3.1 Avoid any exposure to stray ultraviolet radiation that may induce coloration of the dosimeter (see 8.1.1).

8.3.2 Determine the post-irradiation response, R , at the selected analysis wavelength(s) used for calibration of the dosimetry system.

8.3.3 Calculate the net response, ΔR , as follows:

$$\Delta R = R - R_0 \quad (3)$$

8.3.4 Determine the absorbed dose from the calibration curve or response function.

9. Characterization of Each Batch of Dosimeters

9.1 *Reproducibility of Net Response:*

9.1.1 Determine the reproducibility of net response for each batch of dosimeters by analyzing the data from the sets of dosimeters irradiated during the calibration process at each dose value.

9.1.2 Use the sample standard deviation (S_{n-1}) determined during calibration to calculate the coefficient of variation (CV) for each dose value as follows:

$$CV = 100 \times \left[\frac{S_{n-1}}{\Delta R} \right] \quad (4)$$

9.1.3 Document these coefficients of variation and note any that are unusually large.



NOTE 4—In general, if the value of the coefficient of variation is greater than $\pm 2\%$, then a re-determination of the data should be considered or, in the extreme, the batch should be rejected.

9.2 Effect of Absorbed Dose Rate:

9.2.1 The shape (slope) of the calibration curve associated with some radiochromic optical waveguide dosimeters may be affected by the absorbed dose rate for a given application. If an application requires an absorbed dose rate that is significantly different from the absorbed dose rate used in calibrating the dosimetry system, significant error may be introduced into the determination of absorbed dose.

NOTE 5—Appropriate written information regarding the magnitude and effect(s) due to absorbed dose rate may be obtained from the scientific literature (8, 9), dosimeter manufacturer, distributor, irradiation facility operator, or a qualified testing organization.

NOTE 6—The use of electron scavengers in the formulation of the dosimeter can eliminate the absorbed dose rate effect (8, 9).

9.2.2 If the absorbed dose rate for a given application differs from the calibration absorbed dose rate, the effect of this difference on dosimeter response shall be taken into account (see ISO/ASTM Guide 51261).

9.3 Post-Irradiation Characterization:

9.3.1 Some types of dosimeters may fade or may continue color development after irradiation. This effect may depend on post-irradiation storage conditions such as temperature. In order to determine if this is significant in a given application, measure the absorbance at the selected wavelength(s) over the period of anticipated analysis and over the range of expected storage conditions.

9.3.2 If the net response measured in 9.3.1 varies significantly with post-irradiation storage time, apply correction factors for such time-dependent variations taking into account the calibration curve for that batch of dosimeters in order to minimize dosimetric errors during routine application.

9.3.3 For a given set of irradiation conditions, this procedure needs to be performed only once for a given batch of dosimeters.

9.4 Other Factors—The effects of temperature, humidity, background ultraviolet radiation, electron equilibrium, and incident energy spectrum shall be taken into account. Appropriate written information regarding the magnitude and effect(s) upon the measurement made by the dosimetry system may be obtained from the scientific literature (3-5, 8-12), dosimeter manufacturer, distributor, irradiation facility operator, or a qualified testing organization.

10. Application of Dosimetry System

10.1 The number of dosimeters required for the measurement of absorbed dose on or within a material is determined by the precision of the dosimetry system and the required precision associated with the application. Appendix X3 of Practice E 668 describes a statistical method for determining this number.

10.2 Follow the procedures of 8.2 and 8.3.

10.3 Determine the absorbed dose from the net response value(s) and system calibration curve that results from following the procedures in Section 8.

10.4 Record the calculated absorbed dose and all other

relevant data as outlined in Section 11.

11. Minimum Documentation

11.1 Record the dosimeter manufacturer, type, batch number, and code.

11.2 Record or reference the date of calibration, calibration source, and associated instruments used.

11.3 Record or reference the irradiation environmental conditions for the routine dosimeters, including temperature, pressure (if other than atmospheric), relative humidity, and surrounding atmosphere (if other than air).

11.4 Record the date of irradiation and the dates on which the nonirradiated and irradiated dosimeters are analyzed.

11.5 Record the analysis wavelength(s), pre- and post-irradiation response, the net response, and the absorbed dose.

11.6 Record or reference the uncertainty in the absorbed dose.

11.7 Record or reference the quality assurance plan used for dosimetry system application.

12. Measurement Uncertainty

12.1 To be meaningful, a measurement of absorbed dose shall be accompanied by an estimate of uncertainty. Components of uncertainty shall be identified as belonging to one of two groups:

(A) those which are evaluated by statistical methods, or

(B) those which are evaluated by other means.

Additional information is given in ISO/ASTM Guide 51707 and Refs (14) and (15), where these components are referred to as Type A and Type B, respectively. In reporting uncertainty, other classifications such as precision and bias may be useful.

NOTE 7—The identification of Type A and Type B uncertainties is based on the methodology adopted in 1993 by the International Organization for Standardization (ISO) for estimating uncertainty. This is different from the way uncertainty has been traditionally expressed in terms of “precision” and “bias”, where precision is a measure of the extent to which replicate measurements made under specified conditions are in agreement, and bias is a systematic error (see ASTM Terminologies E 170 and E 456 and ASTM Practice E 177). The purpose of using the method of expressing uncertainties as Type A and Type B recommended in the *ISO Guide to the Expression of Uncertainty in Measurement* (15) is to promote an understanding of how uncertainty statements are arrived at and to provide a basis for the international comparison of measurement results.

NOTE 8—ISO/ASTM Guide 51707 defines possible sources of error in dosimetry performed in radiation processing facilities and offers procedures for estimating the resulting magnitude of the uncertainties in the measurement results. Basic concepts of measurement, estimate of the measured value of a quantity, “true” value, error and uncertainty are defined and discussed. Components of uncertainty are discussed and methods are given for evaluating and estimating their values. Their contributions to the standard uncertainty in the reported values of absorbed dose are considered and methods are given for calculating the combined standard uncertainty and an estimate of overall (expanded) uncertainty.

12.2 If this practice is followed, the estimate of the combined uncertainty of an absorbed dose determined by this dosimetry system should be within about $\pm 6\%$ at a 95% confidence level (corresponding to a coverage factor of 2).

13. Keywords

13.1 absorbed dose; dosimetry; electron beams; gamma



radiation; ionizing radiation; optical waveguide dosimetry;
quality control; radiation processing; ICS 17.240

BIBLIOGRAPHY

- (1) Kronenberg, S., McLaughlin, W. L., and Siebentritt, C., "Broad Range Dosimetry and Leuko Dye Optical Waveguides," *Nuclear Instruments and Methods*, 1985, p. 4821.
- (2) Humpherys, K. C., Wilde, W. O., and Kantz, A. D., "An Opti-Chromic Dosimetry System for Radiation Processing of Food," *Radiation Physics and Chemistry*, Vol 22, 1983, p. 291.
- (3) Radak, B. B., and McLaughlin, W. L., "The Gamma-Ray Response of Opti-Chromic Dosimeters," *Radiation Physics and Chemistry*, Vol 23, 1984, p. 673.
- (4) Zhan-Jun, L., Radak, B. B., and McLaughlin, W. L., "Food Irradiation Dosimetry by Opti-Chromic Techniques," *Radiation Physics and Chemistry*, Vol 25, 1985, p. 125.
- (5) McLaughlin, W. L., Kahn, H. M., Warasawas, M., Al-Sheikhly, M., and Radak, B. B., "Optical Waveguide Dosimetry for Gamma Radiation in the Dose Range 0.1 to 30 000 Gy," *Radiation Physics and Chemistry*, Vol 33, 1989.
- (6) McLaughlin, W. L., Humphreys, J. C., Hocken, D., and Chappas, W. J., "Radiochromic Dosimetry for Validation and Commissioning of Industrial Radiation Processes" *Radiation Physics and Chemistry*, Vol 31, 1988, p. 505.
- (7) Xingnong, D., Yuhua, Z., Boling, H., and Jianhuan, Z., "New Method for Measurement of Radiochromic Optical Waveguide (OWG) Dosimeter," *Radiation Physics and Chemistry*, Vol 31, 1988, p. 525.
- (8) Rativanich, N., Radak, B. B., Miller, A., Uribe, R. M., and McLaughlin, W. L., "Liquid Radiochromic Dosimetry," *Radiation Physics and Chemistry*, Vol 18, 1981, p. 1001.
- (9) Humpherys, K.C., and Kantz, A. D., "Improvement in Opti-Chromic Dosimeters for Radiation Processing," *Radiation Physics and Chemistry*, Vol 31, 1988, p. 515.
- (10) McLaughlin, W.L., Boyd, A.W., Chadwick, K.H., McDonald, J.C., and Miller, A., *Dosimetry for Radiation Processing*, Taylor and Francis, New York, NY, 1989, pp. 151-153.
- (11) Sohrabpour, M., Sharpe, P. H. G., and Barrett, J. H., "Dose and Temperature Response of Opti-Chromic Dosimeters," *Radiation Physics and Chemistry*, Vol 31, 1988, p. 435.
- (12) Yuhua, Z., Boling, H., Xingnong, D., Jianhuan, Z., Xianguri, G., and Weigang, L., "Characteristics of Newly Developed Model OWG-86 Radiochromic Optical Waveguide (OWG) Dosimeter," *Radiation Physics and Chemistry*, Vol 31, 1988, p. 521.
- (13) "Absorbed Dose Determination in Photon and Electron Beams," *IAEA Technical Report Series No. 277*, Vienna, 1987.
- (14) Taylor, B.N., and Kuyatt, C.E., "Guidelines for Evaluating and Expressing the Uncertainty of NIST Measurement Results," NIST Technical Note 1297, National Institute of Standards and Technology, Gaithersburg, MD, 1994.
- (15) "Guide to the Expression of Uncertainty in Measurement", International Organization for Standardization, 1993, ISBN 92-67-10188-9. (Available from International Organization for Standardization, 1 rue de Varembé, Case Postale 56, CH-1211, Geneva 20, Switzerland.)

<https://standards.iteh.ai/catalog/standards/sist/5a0bed79-f0c0-42c8-a535->

ASTM International takes no position respecting the validity of any patent rights asserted in connection with any item mentioned in this standard. Users of this standard are expressly advised that determination of the validity of any such patent rights, and the risk of infringement of such rights, are entirely their own responsibility.

This standard is subject to revision at any time by the responsible technical committee and must be reviewed every five years and if not revised, either reapproved or withdrawn. Your comments are invited either for revision of this standard or for additional standards and should be addressed to ASTM International Headquarters. Your comments will receive careful consideration at a meeting of the responsible technical committee, which you may attend. If you feel that your comments have not received a fair hearing you should make your views known to the ASTM Committee on Standards, at the address shown below.

This standard is copyrighted by ISO, Case postale 56, CH-1211, Geneva 20, Switzerland, and ASTM International, 100 Barr Harbor Drive, PO Box C700, West Conshohocken, PA 19428-2959, United States. Individual reprints (single or multiple copies) of this standard may be obtained by contacting ASTM at the above address or at 610-832-9585 (phone), 610-832-9555 (fax), or service@astm.org (e-mail); or through the ASTM website (www.astm.org).