

---

---

**Forestry machinery — Portable chain-  
saws — Minimum handle clearance and  
sizes**

*Machines forestières — Scies à chaîne portatives — Dimensions  
minimales des poignées et des espaces libres autour des poignées*

**iTeh STANDARD PREVIEW**  
**(standards.iteh.ai)**

[ISO 7914:2002](https://standards.iteh.ai/catalog/standards/sist/19f1141f-4eb1-4f32-bbe7-4e1a3236a651/iso-7914-2002)

<https://standards.iteh.ai/catalog/standards/sist/19f1141f-4eb1-4f32-bbe7-4e1a3236a651/iso-7914-2002>



**PDF disclaimer**

This PDF file may contain embedded typefaces. In accordance with Adobe's licensing policy, this file may be printed or viewed but shall not be edited unless the typefaces which are embedded are licensed to and installed on the computer performing the editing. In downloading this file, parties accept therein the responsibility of not infringing Adobe's licensing policy. The ISO Central Secretariat accepts no liability in this area.

Adobe is a trademark of Adobe Systems Incorporated.

Details of the software products used to create this PDF file can be found in the General Info relative to the file; the PDF-creation parameters were optimized for printing. Every care has been taken to ensure that the file is suitable for use by ISO member bodies. In the unlikely event that a problem relating to it is found, please inform the Central Secretariat at the address given below.

**iTeh STANDARD PREVIEW**  
**(standards.iteh.ai)**

[ISO 7914:2002](#)

<https://standards.iteh.ai/catalog/standards/sist/19f1141f-4eb1-4f32-bbe7-4e1a3236a651/iso-7914-2002>

© ISO 2002

All rights reserved. Unless otherwise specified, no part of this publication may be reproduced or utilized in any form or by any means, electronic or mechanical, including photocopying and microfilm, without permission in writing from either ISO at the address below or ISO's member body in the country of the requester.

ISO copyright office  
Case postale 56 • CH-1211 Geneva 20  
Tel. + 41 22 749 01 11  
Fax + 41 22 749 09 47  
E-mail [copyright@iso.ch](mailto:copyright@iso.ch)  
Web [www.iso.ch](http://www.iso.ch)

Printed in Switzerland

## Foreword

ISO (the International Organization for Standardization) is a worldwide federation of national standards bodies (ISO member bodies). The work of preparing International Standards is normally carried out through ISO technical committees. Each member body interested in a subject for which a technical committee has been established has the right to be represented on that committee. International organizations, governmental and non-governmental, in liaison with ISO, also take part in the work. ISO collaborates closely with the International Electrotechnical Commission (IEC) on all matters of electrotechnical standardization.

International Standards are drafted in accordance with the rules given in the ISO/IEC Directives, Part 3.

The main task of technical committees is to prepare International Standards. Draft International Standards adopted by the technical committees are circulated to the member bodies for voting. Publication as an International Standard requires approval by at least 75 % of the member bodies casting a vote.

Attention is drawn to the possibility that some of the elements of this International Standard may be the subject of patent rights. ISO shall not be held responsible for identifying any or all such patent rights.

ISO 7914 was prepared by Technical Committee ISO/TC 23, *Tractors and machinery for agriculture and forestry*, Subcommittee SC 17, *Manually portable forest machinery*.

This third edition cancels and replaces the second edition (ISO 7914:1994), which has been technically revised.

**ITeH STANDARD PREVIEW**  
**(standards.iteh.ai)**

ISO 7914:2002  
<https://standards.iteh.ai/catalog/standards/sist/19f1141f-4eb1-4f32-bbe7-4e1a3236a651/iso-7914-2002>

**iTeh STANDARD PREVIEW**  
**(standards.iteh.ai)**

ISO 7914:2002

<https://standards.iteh.ai/catalog/standards/sist/19f1141f-4eb1-4f32-bbe7-4e1a3236a651/iso-7914-2002>

# Forestry machinery — Portable chain-saws — Minimum handle clearance and sizes

## 1 Scope

This International Standard specifies the minimum clearances and related dimensions for the front and rear handles of portable, hand-held chain-saws with combustion engines.

## 2 Normative reference

The following normative document contains provisions which, through reference in this text, constitute provisions of this International Standard. For dated references, subsequent amendments to, or revisions of, any of these publications do not apply. However, parties to agreements based on this International Standard are encouraged to investigate the possibility of applying the most recent editions of the normative document indicated below. For undated references, the latest edition of the normative document referred to applies. Members of ISO and IEC maintain registers of currently valid International Standards.

ISO 6533:2001, *Forestry machinery — Portable chain-saw front hand-guard — Dimensions and clearances*

## 3 General requirements

### 3.1 Front handle

The front handle shall be designed and positioned such that it provides an unobstructed surface throughout the working area for a gloved hand operating the saw. See Figure 1.

The working area shall be determined with a type A gauge (100 mm length) in accordance with ISO 6533:2001 and Figure 2. The length of the working area shall be limited either by obstructions of the saw or by the reference points  $X_0$  and  $X_1$ , shown in Figure 2.

The reference point  $X_0$  shall be defined by using the gauge kept furthest to the right side of the front handle. Reference point  $X_1$  shall be defined by using the gauge furthest down to the left side, as shown in Figure 2. In both cases, the gauge shall be kept parallel and directly below or to the side of the centreline of the front handle, and in contact with both the handle and the housing of the machine.

When the machine design is such that a type A gauge cannot be inserted between the handle and the housing, the gauge shall be shortened, but by no more than needed.

### 3.2 Rear handle

The rear handle shall provide enough space behind the throttle trigger for a gloved hand operating the saw and shall not extend in front of the throttle trigger.

#### 4 Clearance dimensions

The minimum clearance dimensions of the handles shall be as given in Table 1, which also indicates the figure illustrating each dimension (see Figures 1 to 6).

Table 1 — Clearance dimensions

Handles	Description	Dimension	Figure		Minimum size mm
			Forest work	Tree work service	
Front	Finger clearance in the grip area	<i>A</i>	1	1	35
	Handle grip area	—	2	2	—
	Clearance between the front of the chain-saw body and the handle at the top measured 60 mm to the left of the guide bar plane <sup>a</sup>	<i>B</i>	1	3	38
	Clearance between the front of the chain-saw body and the handle measured at the centreline of the guide bar	<i>C</i>	1	3	25
Front and rear	Perimeter of the cross-section of the handle	<i>H</i>	6	6	65
	Distance from the rear side of the throttle trigger to the centre of the front handle at the top	<i>D</i>	1	—	225
Rear <sup>b</sup>	Finger clearance at the released throttle trigger	<i>E</i>	4	3	30
	Clearance below the released throttle trigger	<i>F<sub>1</sub></i>	4	—	35
		<i>F<sub>2</sub></i>	—	4	25
	Clearance behind the released throttle trigger	<i>G<sub>1</sub></i>	—	—	4 × 25
		<i>G<sub>2</sub></i>	—	3	3 × 25

<sup>a</sup> If the saw is provided with a spiked bumper, the measurement shall be made from the plane of the root of the bumper teeth.

<sup>b</sup> The dimensions shall be gauged free of play, i.e. with a slight initial pressure on the throttle trigger.

Dimensions in millimetres

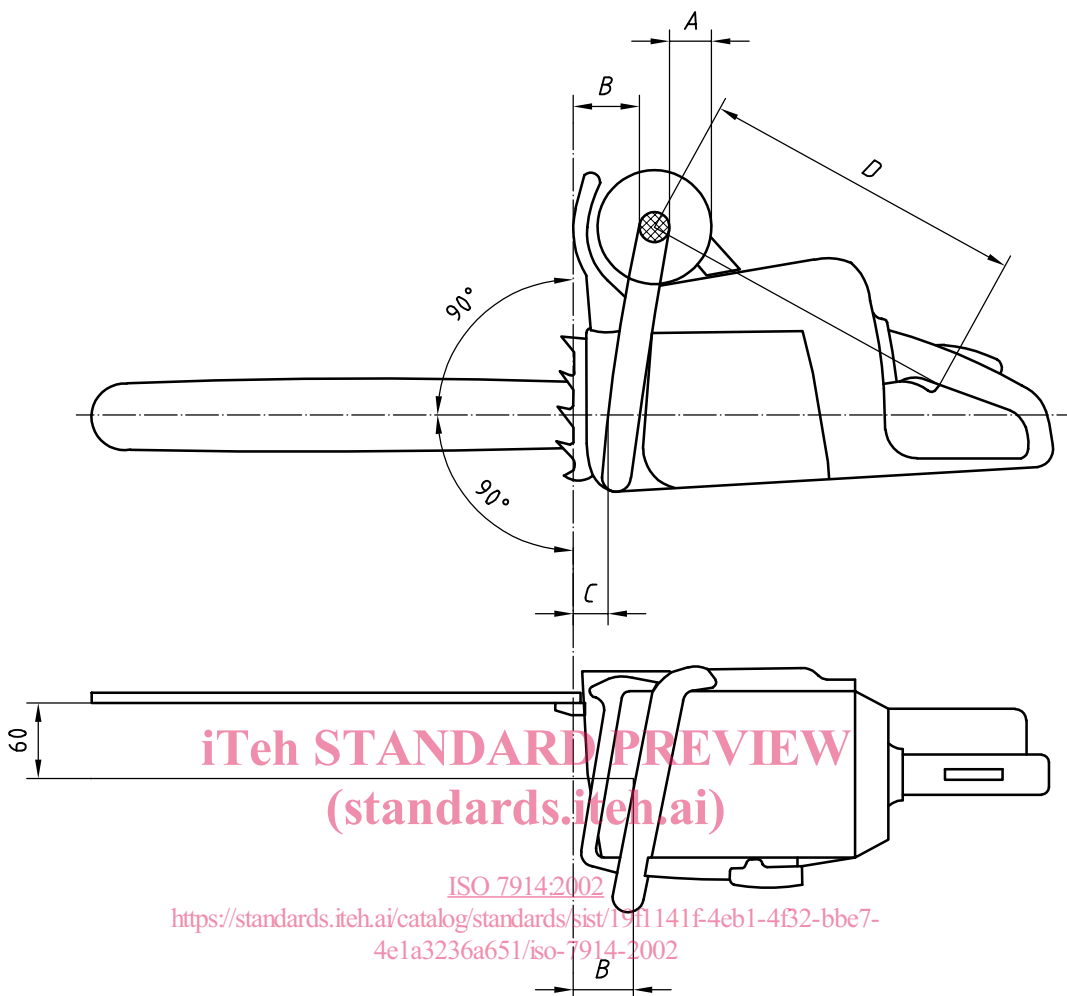

NOTE For A, B, C and D, see Table 1.

Figure 1 — Clearance and distance between front and rear handles of chain-saw for forest work

Dimensions in millimetres

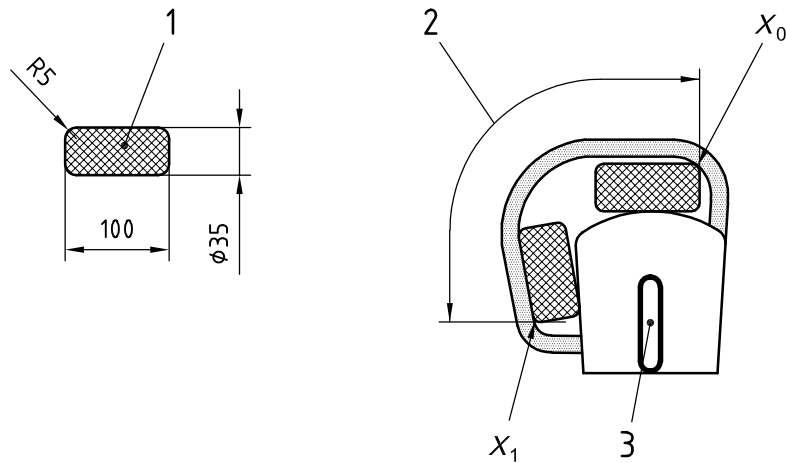

**Key**

- 1 Gauge A (see ISO 6533:2001)
- 2 Grip area
- 3 Rear handle

**Figure 2 — Handle grip area**  
**iTeh STANDARD PREVIEW**  
**(standards.iteh.ai)**

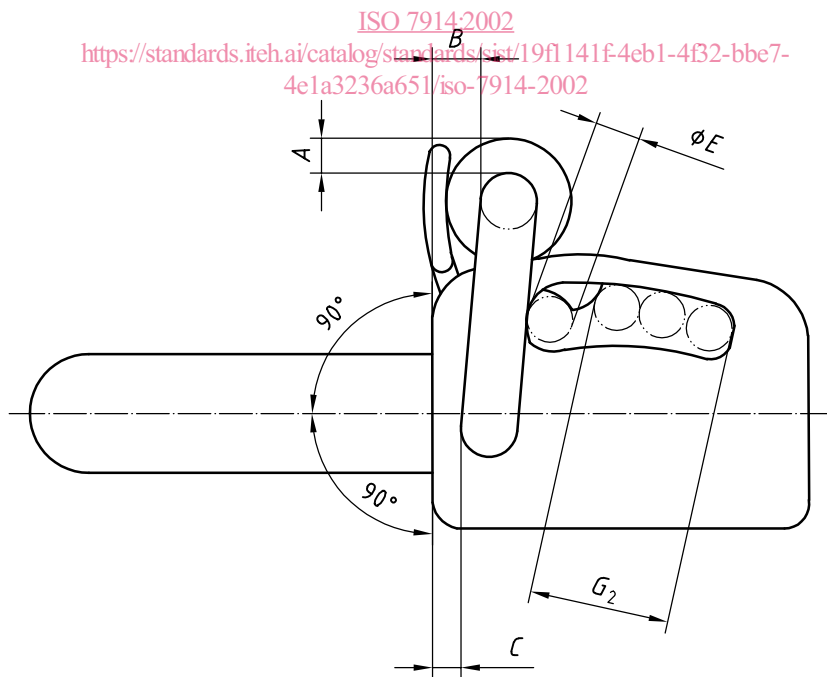

NOTE For *A*, *B*, *C*, *E* and *G*<sub>2</sub>, see Table 1.

**Figure 3 — Front- and rear-handle clearances for chain-saws for tree service**



Dimensions in millimetres

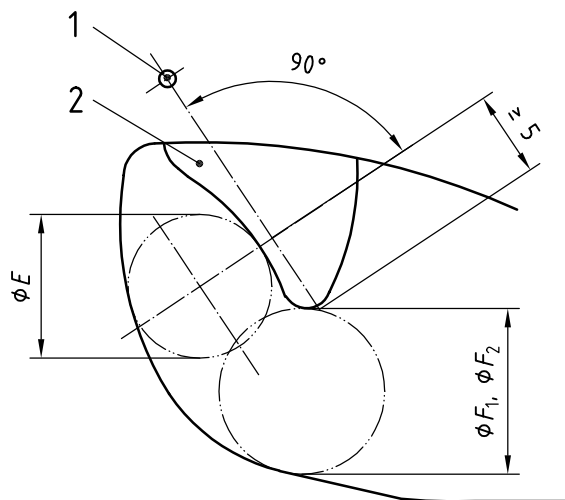

NOTE For  $F_1$  and  $F_2$ , see Table 1.

**Key**

- 1 Pivot point
- 2 Throttle trigger

**iTeh STANDARD PREVIEW**  
**Figure 4 — Finger clearances at released throttle trigger**  
 (standards.iteh.ai)

ISO 7914:2002  
<https://standards.iteh.ai/catalog/standards/sist/19f1141f-4eb1-4f32-bbe7-4e1a3236a651/iso-7914-2002>

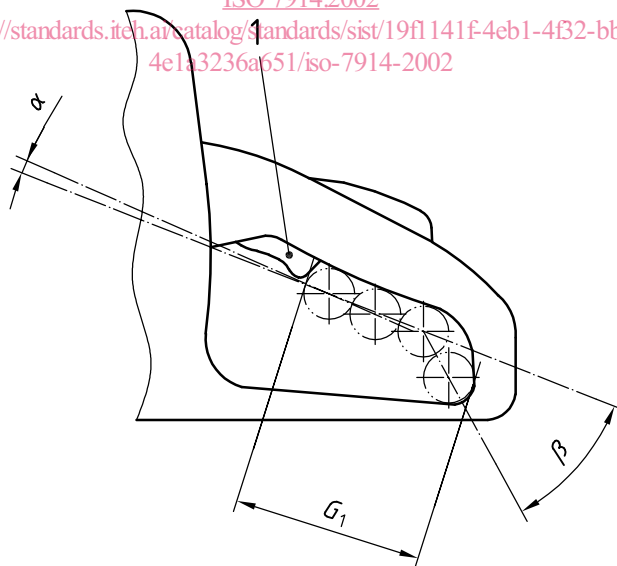

NOTE For  $G_1$ , see Table 1.

**Key**

- 1 Throttle trigger
- $\alpha = -15^\circ$  to  $+15^\circ$
- $\beta = -75^\circ$  to  $+75^\circ$

**Figure 5 — Clearance behind released throttle trigger**